



FASTENING ON STEEL

Installation Typicals



APPLICATION SELECTOR

	X-BT-MR HL Threaded stud (new generation)		S-BT-MR HL Threaded stud		S-BT-MF MT HL Threaded stud		S-BT-MF HL Threaded stud		X-ST-GR Threaded stud	
	Light / Medium duty		Light duty		Light duty		Light duty		Light duty	
	Base material thickness ≥ 8 mm (5/16")		Base material thickness ≥ 6 mm (1/4")		Base material thickness ≥ 6 mm (1/4")		Base material thickness ≥ 6 mm (1/4")		Base material thickness ≥ 6 mm (15/64")	
	Metric	Imperial	Metric	Imperial	Metric	Imperial	Metric	Imperial	Metric	Imperial
 Cantilever	Page 15	Page 63	Page 29	Page 77	Page 29	Page 77	Page 29	Page 77	Page 49	Page 97
 Braced cantilever	Page 16	Page 64	Page 31	Page 79	Page 31	Page 79	Page 31	Page 79	Page 50	Page 98
 Strut to steel	Page 17	Page 65	Page 33	Page 81	Page 33	Page 81	Page 33	Page 81	Page 51	Page 99
 Strut to steel	Page 18	Page 66	Page 34	Page 82	Page 34	Page 82	Page 34	Page 82	Page 52	Page 100
 T-Post (ceiling)	Page 19	Page 67	Page 35	Page 83	Page 35	Page 83	Page 35	Page 83	Page 53	Page 101
 T-Post (floor)	Page 20	Page 68	Page 37	Page 85	Page 37	Page 85	Page 37	Page 85	Page 54	Page 102
 U-Frame (ceiling)	Page 21	Page 69	Page 39	Page 87	Page 39	Page 87	Page 39	Page 87	Page 55	Page 103
 L-Post	Page 22	Page 70	Page 40	Page 88	Page 40	Page 88	Page 40	Page 88	Page 56	Page 104
 Inclined cantilever	Page 23	Page 71	Page 42	Page 90	Page 42	Page 90	Page 42	Page 90	Page 57	Page 105
 Junction boxes / switches	Page 24	Page 72	Page 44	Page 91	Page 44	Page 91	Page 44	Page 91	Page 58	Page 106

USAGE / STRUCTURAL DESIGN DISCLAIMER — 2018/05/04

- This document is updated regularly—please check for an update before using the document and always use the latest version. Please make sure to not use the document later than the indicated expiry date (left lower corner).
- Mentioned values are ONLY reflecting capacity of the fasteners / studs themselves. Structural analysis of support / structure is NOT in Hilti scope as Hilti is not aware of the relevant data.
- The user has to make sure that all instructions (for tools, fasteners and auxiliary material used) are followed strictly to achieve the required performance.
- All typical calculations are based on the capacity that is mentioned in the description of the fasteners—please refer to the respective detailed technical description. Results are rounded for simplification and to harmonize metric and imperial units.
- **Assumption:** calculation is based on rigid system model, without deformation of baseplate or cantilever.
- **Assumption:** in applications which introduce tensile and shear load to the fastener, the shear loads are assumed to be carried only by the top threaded stud(s) which also carry the tensile load, this is therefore a worst-case scenario.
- **Assumption:** considered loadings are only the static loads of the cable tray, pipe or other installed elements and the weight of the support itself.
 - Load is always acting in the center of the cable tray, pipe or installed elements, the dimension L1 is from that point to the fasteners plane—please see the description in the respective examples.
 - No other loads (e.g. wind load or loads due to installation / transportation) are known and in scope of the calculation.
- **Assumption:** there is no load in axis of the cable tray or pipe due to thermal expansion or other phenomena.

USAGE / STRUCTURAL DESIGN EXAMPLE LOADS* — CABLE TRAY AND PIPE

Example loads* can be calculated based on a standard cable tray with 50 mm height or pipe (see example tables to the right)

*Loads are typically stated in technical documents as “Force [kN]”, however it is more comprehensible to state the loads as “Weight [kg]” conversion as follows:

1 kg = 9.81 N / (weight to force);
 100 kg = 0.98 kN;
 1000 kg = 9.8 kN / (force to weight);
 1 kN = 102 kg;
 10 kN = 1019 kg

Pipe	Diameter [mm]	Load [kg/m]	Load [lb/ft]
25 DN x 33.4 OD	25	3.6	2.4
40 DN x 48.3 OD	40	6.1	4.1
50 DN x 60.3 OD	50	9.8	6.6
80 DN x 88.9 OD	80	15.8	10.6
100 DN x 114.3 OD	100	31.0	20.8
125 DN x 141.3 OD	125	45.9	30.8
150 DN x 168.3 OD	150	63.6	42.7
200 DN x 219.1 OD	200	96.9	65.1

- Load [kg/m] includes the pipe and media (by simplified calculation)
- Pipe weight is in the range of 3.0–57 kg/m (for diameter of 25–200 mm; with 1 mm pipe insulation)
- Media weight is calculated based on density of water 1.0 kg/l (per pipe cross-section) density dependent on media (e.g. oil 0.6–0.9 kg/l)

Cable tray	Width [mm]	Load [kg/m]	Load [lb/ft]
50 W x 50 H	50	7.7	5.2
100 W x 50 H	100	14.5	9.7
150 W x 50 H	150	21.2	14.2
200 W x 50 H	200	27.9	18.7
300 W x 50 H	300	41.4	27.8
450 W x 50 H	450	61.6	41.4
600 W x 50 H	600	81.9	55.0
900 W x 50 H	900	122.3	82.2

- Load [kg/m] includes the cable tray and cable carried by the cable tray (by simplified calculation)
- Cable tray weight (steel, t = 1.25 mm) is in the range of 1.5–9.8 kg/m (for width of 50–900 mm)
- Cable weight is calculated based on an average filling density of 0.25 kg/m/cm² cable tray cross-section typical cable range from 0.15–0.35 kg/m/cm²

FASTENERS USED FOR TYPICALS CALCULATION

Blunt Tip / Sharp Tip Fasteners

Key Questions	Fastener	X-BT-MR Threaded stud (new generation)	S-BT-MR HL Threaded stud	S-BT-MF MT HL Threaded stud	S-BT-MF HL Threaded stud	X-ST-GR Threaded stud
	Material	Stainless steel A4, 316	Stainless steel A4, 316	Carbon steel (duplex coated)	Carbon steel (duplex coated)	Stainless steel A2, 304
1	Corrosive environment	Highly corrosive C4, C5	Highly corrosive C4, C5	Mildly corrosive C3	Mildly corrosive C3	Mildly corrosive C3
2	Damage to coating	No @ ≥ 8 mm ($\frac{5}{16}$ "	No @ ≥ 6 mm ($\frac{1}{4}$ "	No @ ≥ 6 mm ($\frac{1}{4}$ "	No @ ≥ 6 mm ($\frac{1}{4}$ "	Yes
3	Base material thickness	≥ 8 mm ($\frac{5}{16}$ " full steel	≥ 6 mm ($\frac{1}{4}$ " full steel	≥ 6 mm ($\frac{1}{4}$ " full steel	≥ 6 mm ($\frac{1}{4}$ " full steel	6 mm ($\frac{1}{4}$ " full steel
	Base material	<ul style="list-style-type: none"> • Steel • Stainless Steel • Cast iron 	<ul style="list-style-type: none"> • Steel 	<ul style="list-style-type: none"> • Steel 	<ul style="list-style-type: none"> • Steel 	<ul style="list-style-type: none"> • Steel
	Tensile load (N_{rec})	3.6 kN (810 lb)	Steel 3.6 kN (810 lb)	Steel 3.6kN (810 lb)	Steel 3.6 kN (810 lb)	1.8 kN (405 lb)
	Shear load (V_{rec})	4.3 kN (970 lb)	Steel 4.0 kN (900 lb)	Steel 4.0kN (900 lb)	Steel 2.75 kN (618 lb)	1.8 kN (405 lb)
	Tightening torque	20 Nm (14.8 ft-lb)	Steel 16 Nm (11.8 ft-lb)	Steel 16 Nm (11.8 ft-lb)	16 Nm (11.8 ft-lb)	8.5 Nm (6.3 ft-lb)
	Pilot hole required	Yes	Yes	Yes	Yes	No
	Available thread diameter	M8 MW6 MW10	M8 MW10	MW10	M8 MW10	M8
	Max. fastened material height	$t_1 \leq 15$ mm ($\frac{9}{16}$ " Removable	$t_1 \leq 15$ mm ($\frac{9}{16}$ " Removable	$t_1 \leq 15$ mm Removable	$t_1 \leq 15$ mm ($\frac{9}{16}$ " Removable	$t_1 \leq 10$ mm ($\frac{3}{8}$ " Removable
	Required equipment	SF BT 22-A and DX 351-BT	SBT 4-A22 + S-DG or SBT 6-22	SBT 4-A22 + S-DG or SBT 6-22	SBT 4-A22 + S-DG or SBT 6-22	DX 5 and DX 76 PTR
	Approvals	DNV, ABS, LR, BV, ICC-ES, ETA	DNV, ABS, LR, BV, ICC-ES, ETA	DNV, ABS, LR, BV, ICC-ES, ETA	DNV, ABS, LR, BV, ICC-ES, ETA	ICC-ES, ABS

Min steel grade S235 | Grade A36 Steel | Refer to the Direct Fastening Technology Manual (DTFM) for detailed technical data

Values are based on ETA-23/0001

HOW TO USE THIS DOCUMENT

How to interpret the sketches

L1 is in all cases the relevant dimension of the lever arm / cantilever “distance from fastener to load”

F is in all cases the total load which has to be borne by the structure and it includes the pay load and the load of the structure itself

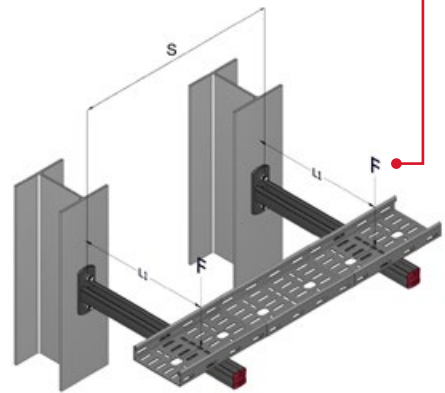
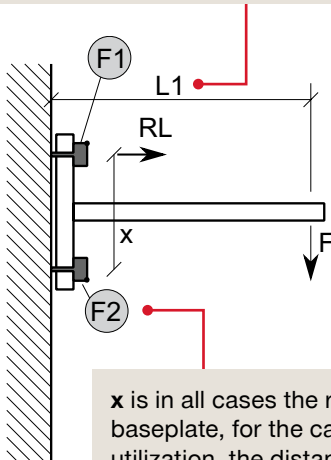

x is in all cases the relevant dimension of the baseplate, for the calculation of the fastener utilization, the distance of the involved fasteners

How to read the technical tables

Result parameter L1 in [mm]	Result: L1 [mm]	F [kg]							
		50	75	100	125	150	200	250	300
	→ Load in [kN]	0.49	0.74	0.98	1.23	1.47	1.96	2.45	2.94
2 nd base parameter x in [mm]	80	585	390	285	210	165	105	70	50
	100	730	485	355	265	205	135	90	60
	125	915	610	445	335	260	170	115	75
	150	1100	730	530	400	310	200	135	90
	175	1280	855	620	470	365	235	160	110
	200	1465	975	710	535	415	270	180	125

Result parameter Load in [kg]	Result: Load F [kg]	L1 [mm]							
		150	200	250	400	600	800	1000	1200
2 nd base parameter x in [mm]	80	160	130	110	70	45	35	25	20
	100	185	155	130	90	60	45	35	30
	125	215	180	155	105	75	55	45	35
	150	235	200	175	125	90	65	55	45
	175	255	220	190	140	100	80	60	50
	200	275	235	210	155	110	90	70	60

HOW TO USE THIS DOCUMENT

We can utilize the following tables to solve different typical use cases

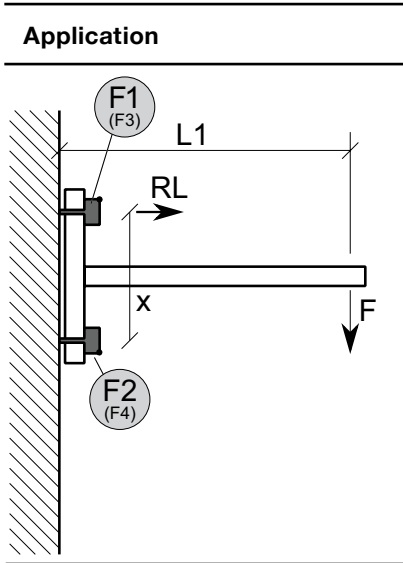

- F1 - F4 fasteners
- F load on the support
- RL resulting load (tensile and shear load)
- L1 support lever length
- x support basis (=distance of fasteners)

It is recommended to position the support lever half way between the fasteners to ease installation

Customer's typical use cases

Use Case	L1	x	F	RL	Typical customer task
A	?	✓	✓	✓	"I know the loads and use existing baseplates, I have different lever-arm length, so what is the maximum L1 ?"
B	✓	?	✓	✓	"I know loads and the required lever-arm. I want to minimize the baseplate size, so what is minimum x ?"
C	✓	✓	?	✓	"I already have supports available and want to know maximum allowable load, so what maximum F can I use?"
D	✓	✓	✓	?	"I already have supports available and want to minimize the number of supports, so how do I use RL for that?"

✓ Parameter is known; ? Parameter is the table output

USE CASES IN DETAIL

Use Case A: maximize L1 and achieve a required length

Application

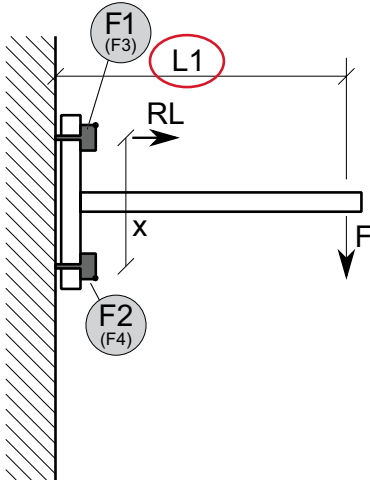

L1	x	F	RL
?	✓	✓	✓
✓	?	✓	✓
✓	✓	?	✓
✓	✓	✓	?

F1 – F4 fasteners
 F load on the support
 RL resulting load
 (tensile and shear load)
 L1 support lever length
 x support basis
 (=distance of fasteners)

Example – Use Case A

Outset situation

- Cable tray type 450 W x 50 H; span $s = 2.2 \text{ m}$ → results in load of 140 kg per support (example table: $2.2 \text{ m} \times 63.63 \text{ kg/m}$)
- N is defined by 4 fasteners (e.g. X-BT-MR)
- $x = 175 \text{ mm}$ (baseplates are already available and by thus the distance x is already given)

Task

The lever-arm length should be as long as possible to gain flexibility. It needs to be at least 0.3 m

Solution

Step 1: select the typical slide for the right application and number of fasteners (2 or 4 studs)

Step 2: select the table (preferred one for this task is the table which gives “L1” as result)

Step 3: select the appropriate column with the load F (which is equal or greater than the given load)

Step 4: select the appropriate row with the support distance x (which is equal or smaller than the given support distance)

Result: $x = 855 \text{ mm}$ the maximum length L1 is 380 mm

The screenshot shows the HILTI technical document for 'FASTENING CANTILEVER SUPPORT WITH X-BT-MR'. It includes an application diagram, boundary conditions, and technical assessment tables. The tables show the relationship between load F [kg], support distance x [mm], and support lever length L1 [mm] for different numbers of fasteners (2 and 4 studs).

Result:	F [kg]								
L1 [mm]	50	75	100	150	200	250	300		
→ Load in [kN]	0.49	0.74	0.98	1.23	1.47	1.96	2.45	2.94	
x [mm]	80	1170	780	585	465	390	285	210	165
	100	1465	975	730	585	485	355	265	205
	125	1830	1220	915	730	610	445	335	260
	150	2200	1465	1100	880	730	530	400	310
	175	2665	1740	1280	1020	855	620	470	365
	200	2935	1955	1465	1170	975	710	535	415

Ⓡ L1 is 855 mm — meets requirement

USE CASES IN DETAIL

Use Case B: minimize x and determine required baseplate

Application

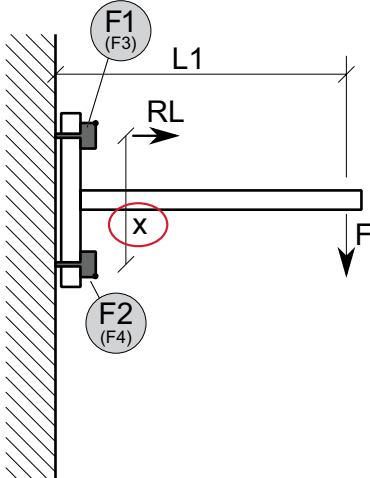

L1	x	F	RL
?	✓	✓	✓
✓	?	✓	✓
✓	✓	?	✓
✓	✓	✓	?

F1 – F4 fasteners
 F load on the support
 RL resulting load
 (tensile and shear load)
 L1 support lever length
 x support basis
 (=distance of fasteners)

Example – Use Case B

Outset situation

- Cable tray type 450 W x 50 H; span $s = 2.2$ m → results in load of 140 kg per support (example table: 2.2 m x 63.63 kg/m)
- N is defined by 4 fasteners (e.g. X-BT-MR)
- L1 = 300 mm (required position of the cable tray, existing cantilever supports)

Task

The size of the baseplate, distance of fasteners (e.g. X-BT-MR) should be as short as possible, existing baseplates provide $x = 80$ mm

Solution

Step 1: select the typical slide for the right application and number of fasteners (2 or 4 studs)

Step 2: select the table (preferred one for this task is the table which gives “L1” as result; the right table would also work)

Step 3: select the appropriate column with the load F (which is equal or greater than the given load)

Step 4: select the appropriate row with the lever arm distance L1 (which is equal or greater than the given lever arm distance)

Result: the minimum required support distance x is 80 mm → the existing baseplate with $x = 80$ mm works fine

FASTENING CANTILEVER SUPPORT WITH X-BT-MR®
 Two / Four X-BT-MR Threaded Studs

Application

- Fastening of cable trays, pipes on a horizontal cantilever support, fastened on a vertical structure
- Support is fastened by two / four X-BT-MR on both support and brace baseplate with distance x
- L1 is the distance of the load center to the vertical structure surface
- Load F is the acceptable total load (all dead load including)

Boundary conditions

- These values are ONLY reflecting capacity of X-BT-MR threaded stud. Structural analysis of support / structure is NOT in Hilti scope. See the detailed statements in disclaimer – 2018/05/04
- Shear load fully carried by one / two top X-BT-MR (worst case)
- Load F acting at the distance of L1 from structure surface

Technical assessment – maximum of F (depending on load F or lever arm length L1 and baseplate distance x)

2 studs

Result:	F [kg]							L1 [mm]											
L1 [mm]	50	75	100	125	150	200	250	300	Load	100	200	250	300	400	500	600	800	1000	1200
→ Load in [kN]	0.49	0.74	0.98	1.23	1.47	1.96	2.45	2.94	100	100	100	100	100	100	100	100	100	100	
x [mm]	80	80	80	80	80	80	80	80	80	80	80	80	80	80	80	80	80	80	

4 studs

Result:	F [kg]							L1 [mm]											
L1 [mm]	50	75	100	125	150	200	250	300	Load	100	200	250	300	400	500	600	800	1000	1200
→ Load in [kN]	0.49	0.74	0.98	1.23	1.47	1.96	2.45	2.94	100	100	100	100	100	100	100	100	100	100	
x [mm]	80	80	80	80	80	80	80	80	80	80	80	80	80	80	80	80	80	80	

NOTE: load capacity used for calculation $N_{t,s} = 3.6$ kN (axial) / $V_{s,d} = 4.3$ kN (shear)

Issued August 2018, expiry January 2021

Result:	F [kg]								
L1 [mm]	50	75	100	125	150	200	250	300	
→ Load in [kN]	0.49	0.74	0.98	1.23	1.47	1.96	2.45	2.94	
R	80	1170	780	585	485	390	4	210	165
x	100	1465	975	730	585	485	355	265	205
	125	1830	1220	915	730	610	445	335	260
	150	2200	1465	1100	880	730	530	400	310
	175	2565	1710	1280	1025	855	620	470	365
	200	2935	1955	1465	1170	975	710	535	415

R x is 80 mm—meets requirement

USE CASES IN DETAIL

Use Case C: determine allowed load

Application

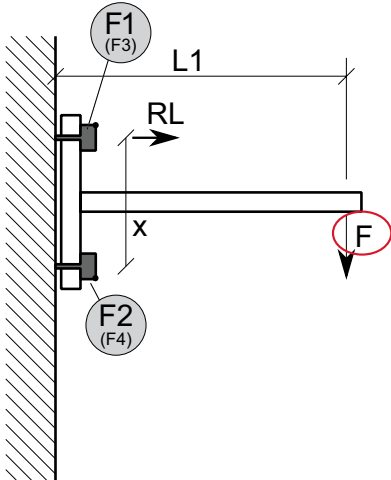

L1	x	F	RL
?	✓	✓	✓
✓	?	✓	✓
✓	✓	?	✓
✓	✓	✓	?

- F1 – F4 fasteners
- F load on the support
- RL resulting load (tensile and shear load)
- L1 support lever length
- x support basis (=distance of fasteners)

Example – Use Case C

Outset situation

- **x = 175 mm** (existing cantilever supports)
- **L1 = 400 mm** (required position of the cable tray, existing cantilever supports)
- **N is defined by 4 fasteners** (e.g. X-BT-MR)

Task

How much load **F** is allowed

Solution

Step 1: select the typical slide for the right application and number of fasteners (2 or 4 studs)

Step 2: select the table (preferred one for this task is the table which gives “**F**” as result)

Step 3: select the appropriate column with the lever arm length **L1** (which is equal or greater than the given length)

Step 4: select the appropriate row with the support distance **x** (which is equal or smaller than the given support distance)

Result: the maximum load **F** is 140 kg (allows e.g. 2.2 m * 63.63 kg/m = cable tray 450 W x 50 H, see example table)

FASTENING CANTILEVER SUPPORT WITH X-BT-MR*

Two / Four X-BT-MR Threaded studs

Application

- Fastening of cable trays, pipes on a horizontal cantilever support, fastened on a vertical structure
- Support is fastened by two / four X-BT-MR on both support and brace baseplate with distance x
- L1 is the distance of the load center to the vertical structure surface
- Load F is the acceptable total load (all dead load including)

Boundary conditions

- * These values are ONLY reflecting capacity of X-BT-MR threaded stud. Structural analysis of support / structure is NOT in Hilti scope. See the detailed statements in disclaimer – 2018/05/04
- ** Shear load fully carried by one / two top X-BT-MR (worst case)
- Load F acting at the distance of L1 from structure surface

Technical assessment – maximum of F (depending on load F or lever arm length L1 and baseplate distance x)

Result: L1 [mm]	F [kg]								L1 [mm]									
	50	75	100	125	150	200	250	300	100	150	200	250	300	400	600	800	1000	1200
80	580	390	285	210	165	105	70	50	80	160	130	110	70	45	35	25	20	15
100	730	485	355	265	205	135	90	60	100	185	155	130	90	60	45	35	30	20
125	915	610	445	335	260	170	115	75	125	215	180	155	105	75	55	45	35	25
150	1100	730	530	400	310	200	135	90	150	235	200	175	125	90	65	55	45	35
175	1280	855	620	470	365	235	160	110	175	255	220	190	140	100	80	60	50	40
200	1465	975	710	535	415	270	180	125	200	275	235	210	155	110	90	70	60	50

NOTE: load capacity used for calculation $N_{t,R} = 3.6 \text{ kN (axial)}$ / $V_{t,R} = 4.3 \text{ kN (shear)}$

Result: Load F [kg]	L1 [mm]							
	150	200	300	400	600	800	1000	1200
80	320	260	220	145	95	70	55	45
100	375	310	260	180	120	90	70	60
125	430	360	310	215	150	110	90	75
150	475	405	350	250	185	135	110	90
175	515	440	385	280	205	160	125	105
200	550	475	420	310	225	180	145	120

F is 280 kg

USE CASES IN DETAIL

Use Case D: determine required fastener

Application

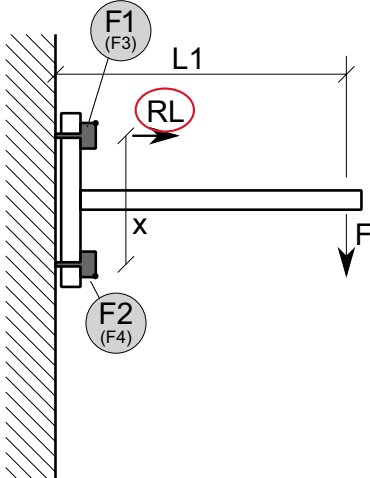

L1	x	F	RL
?	✓	✓	✓
✓	?	✓	✓
✓	✓	?	✓
✓	✓	✓	?

F1 – F4 fasteners
 F load on the support
 RL resulting load
 (tensile and shear load)
 L1 support lever length
 x support basis
 (=distance of fasteners)

Example – Use Case D

Outset situation

- $x = 175 \text{ mm}$ (existing cantilever supports)
- $L1 = 400 \text{ mm}$ (required position of the cable tray, existing cantilever supports)
- F is 100 kg

Task

How many fasteners (e.g. X-BT-MR) are required (2 or 4 supported by the existing cantilever supports)

Solution

Step 1: select the typical slide for the right application and number of fasteners (here you need 2 and 4 studs)
 Follow the steps 1–4 through for both cases “2 X-BT-MR” and “4 X-BT-MR”

Step 2: select the table (preferred one for this task is the table which gives “F” as result)

Step 3: select the appropriate column with the lever arm length $L1$ (which is equal or greater than the given length)

Step 4: select the appropriate row with the support distance x (which is equal or smaller than the given support distance)

Result: the maximum load is 140 kg (2 X-BT-MR). You can use 2 X-BT-MR with the given load 100 kg

Result:		L1 [mm]							
Load F [kg]		150	200	300	400	600	800	1000	1200
x [mm]	80	160	130	110	70	45	35	25	20
	100	185	155	130	90	60	45	35	30
	125	215	180	155	105	75	55	45	35
	150	235	200	175	125	85	65	55	45
	175	255	220	190	140	100	80	60	50
	200	275	235	210	155	110	90	70	60

③ 4 X-BT-MR: F is 280 kg
 ④ 2 X-BT-MR: F is 140 kg → 2 X-BT-MR





X-BT-MR THREADED STUD (NEW GENERATION)

Metric

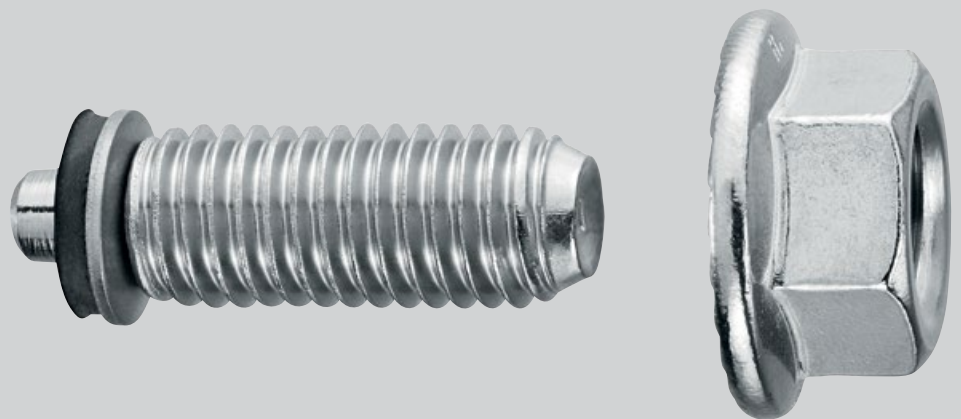

X-BT-MR (NEW GENERATION) TECHNICAL DATA

X-BT-MR technical data

- **Drill hole type / base material:** Pilot hole, $t_{II} \geq 8 \text{ mm}$ (0.31")
- **Base material:** Steel S235 / A36 (higher steel strength is possible, increases the rec. load)
- **Recommended interaction for combined load:** $N_{rec} = 3.6 \text{ kN}$ (axial) / $V_{rec} = 4.3 \text{ kN}$ (shear)

V-N (shear and tension)

$$\frac{V}{V_{rec}} + \frac{N}{N_{rec}} \leq 1.2 \quad \text{with} \quad \frac{V}{V_{rec}} \leq 1.0 \quad \text{and} \quad \frac{N}{N_{rec}} \leq 1.0$$

For further technical data refer to DFTM / New Generation Hilti X-BT-GR, X-BT-MR and X-BT-ER Threaded Fastener Specification [June 2018]

FASTENING CANTILEVER SUPPORT WITH X-BT-MR*

Two / Four X-BT-MR Threaded studs

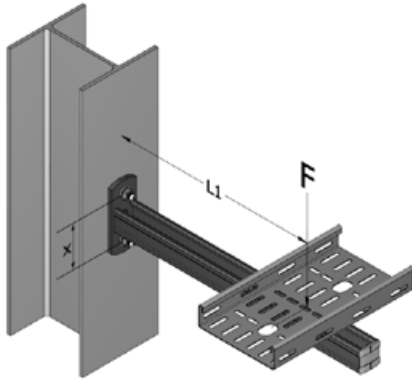

Application

- Fastening of cable trays, pipes on a horizontal cantilever support, fastened on a vertical structure
- Support is fastened by two / four X-BT-MR on both support and brace baseplate with distance x
- L1 is the distance of the load center to the vertical structure surface
- Load F is the acceptable total load (all dead load including)

Boundary conditions

- These values are ONLY reflecting capacity of X-BT-MR threaded stud. Structural analysis of support / structure is NOT in Hilti scope. See the detailed statements in disclaimer—2018/05/04
- Shear load fully carried by one / two top X-BT-MR (worst-case)
- Load F acting at the distance of L1 from structure surface

Technical assessment — maximum of F (depending on load F or lever arm length L1 and baseplate distance x)

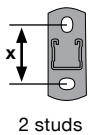

Result: L1 [mm]	F [kg]								
	50	75	100	125	150	200	250	300	
→ Load in [kN]	0.49	0.74	0.98	1.23	1.47	1.96	2.45	2.94	
x [mm]	80	585	390	285	210	165	105	70	50
	100	730	485	355	265	205	135	90	60
	125	915	610	445	335	260	170	115	75
	150	1100	730	530	400	310	200	135	90
	175	1280	855	620	470	365	235	160	110
	200	1465	975	710	535	415	270	180	125

Result: Load F [kg]	L1 [mm]								
	150	200	250	400	600	800	1000	1200	
x [mm]	80	160	130	110	70	45	35	25	20
	100	185	155	130	90	60	45	35	30
	125	215	180	155	105	75	55	45	35
	150	235	200	175	125	90	65	55	45
	175	255	220	190	140	100	80	60	50
	200	275	235	210	155	110	90	70	60

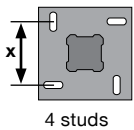

Result: L1 [mm]	F [kg]								
	50	75	100	125	150	200	250	300	
→ Load in [kN]	0.49	0.74	0.98	1.23	1.47	1.96	2.45	2.94	
x [mm]	80	1170	780	585	465	390	285	210	165
	100	1465	975	730	585	485	355	265	205
	125	1830	1220	915	730	610	445	335	260
	150	2200	1465	1100	880	730	530	400	310
	175	2565	1710	1280	1025	855	620	470	365
	200	2935	1955	1465	1170	975	710	535	415

Result: Load F [kg]	L1 [mm]								
	150	200	250	400	600	800	1000	1200	
x [mm]	80	320	260	220	145	95	70	55	45
	100	375	310	260	180	120	90	70	60
	125	430	360	310	215	150	110	90	75
	150	475	405	350	250	180	135	110	90
	175	515	440	385	280	205	160	125	105
	200	550	475	420	310	225	180	145	120

NOTE: load capacity used for calculation $N_{rec} = 3.6 \text{ kN}$ (axial) / $V_{rec} = 4.3 \text{ kN}$ (shear)

*X-BT-MR is the new generation X-BT

[FASTENER SYSTEM](#)
[FASTENER OVERVIEW](#)
[FASTENER TECHNICAL DETAILS](#)
[APPLICATION OVERVIEW](#)
[HOW TO USE THIS DOCUMENT](#)
[DISCLAIMER](#)

FASTENING BRACED CANTILEVER SUPPORT WITH X-BT-MR*

Two / Four X-BT-MR Threaded studs

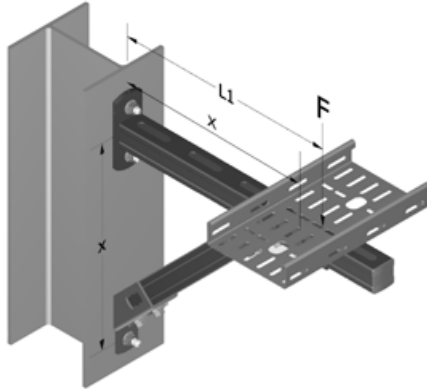

Application

- Fastening of cable trays, pipes on a horizontal, braced cantilever support, fastened on a vertical structure
- Support is fastened by three / six X-BT-MR on both support and brace baseplate with distance x
- L1 is the distance of the load center to the vertical structure surface, the angle of the brace is 45°
- Load F is the acceptable total load (all dead load including)

Boundary conditions

- These values are ONLY reflecting capacity of X-BT-MR threaded stud. Structural analysis of support / structure is NOT in Hilti scope. See the detailed statements in disclaimer—2018/05/04
- Shear load fully carried by one / two top X-BT-MR (worst-case)
- Load F acting at the distance of L1 from structure surface

Technical assessment — maximum of F (depending on load F or lever arm length L1 and baseplate distance x)

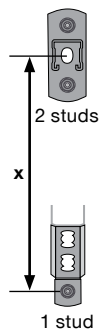

Result: L1 [mm]	F [kg]							
	50	75	100	125	150	200	250	300
→ Load in [kN]	0.49	0.74	0.98	1.23	1.47	1.96	2.45	2.94
x [mm]	100	500	390	325	280	215	175	145
	150	750	585	485	420	325	260	215
	200	1000	780	650	560	435	350	290
	350	1755	1370	1140	985	765	610	510
	500	2505	1955	1630	1410	1095	875	730
	800	4010	3135	2605	2255	1750	1400	1165

Result: Load F [kg]	L1 [mm]							
	150	200	250	400	600	800	1000	1200
x [mm]	100	290	215	175	105	70		
	150	435	325	260	160	105		
	200		435	350	215	145		
	350				380	255		
	500					365		
	800							

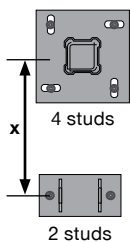

Result: L1 [mm]	F [kg]							
	50	75	100	125	150	200	250	300
→ Load in [kN]	0.49	0.74	0.98	1.23	1.47	1.96	2.45	2.94
x [mm]	100			585	500	390	325	280
	150			880	750	585	485	420
	200			1175	1000	780	650	560
	350			2060	1755	1370	1140	985
	500			2945	2505	1955	1630	1410
	800			4715	4010	3135	2605	2255

Result: Load F [kg]	L1 [mm]								
	150	200	250	400	600	800	1000	1200	
x [mm]	100	580	435	350	215	145			
	150	875	655	525	325	215	160	130	
	200		875	700	435	290	215	175	145
	350				765	510	380	305	255
	500					730	545	435	365
	800						875	700	580

NOTE: load capacity used for calculation $N_{rec} = 3.6 \text{ kN}$ (axial) / $V_{rec} = 4.3 \text{ kN}$ (shear)

*X-BT-MR is the new generation X-BT

[FASTENER SYSTEM](#)
[FASTENER OVERVIEW](#)
[FASTENER TECHNICAL DETAILS](#)
[APPLICATION OVERVIEW](#)
[HOW TO USE THIS DOCUMENT](#)
[DISCLAIMER](#)

FASTENING STRUT TO STEEL WITH X-BT-MR*

Two X-BT-MR Threaded studs

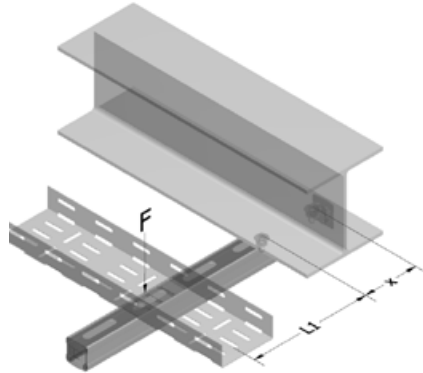

Application

- Fastening of cable trays, pipes on a horizontal cantilever support, fastened on a horizontal structure
- Support is fastened by two X-BT-MR (horizontal distance x)
- L1 is the distance of the load center to the vertical structure surface
- Load F is the acceptable total load (all dead load including)

Boundary conditions

- These values are ONLY reflecting capacity of X-BT-MR threaded stud. Structural analysis of support / structure is NOT in Hilti scope. See the detailed statements in disclaimer—2018/05/04
- Load F acting at the distance of L1 from structure surface

Technical assessment – maximum of L1 and F (depending on load F or lever arm length L1 and X-BT-MR distance x)

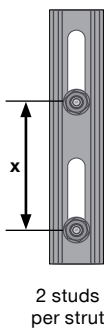

Result: L1 [mm]	F [kg]								
	50	75	100	125	150	200	250	300	
→ Load in [kN]	0.49	0.74	0.98	1.23	1.47	1.96	2.45	2.94	
x [mm]	80	505	310	210	150	115	65	35	15
	100	630	385	265	190	140	80	45	20
	125	790	485	330	240	180	100	55	25
	150	950	580	400	290	215	125	70	30
	175	1105	680	465	335	250	145	80	35
	200	1265	775	530	385	285	165	90	40

Result: Load F [kg]	L1 [mm]								
	150	200	250	400	600	800	1000	1200	
x [mm]	80	125	100	85	60	40	30	25	20
	100	145	120	100	70	50	40	30	25
	125	165	140	120	85	60	45	40	30
	150	180	155	135	100	70	55	45	40
	175	195	170	150	110	80	65	50	45
	200	205	180	160	120	90	70	60	50

NOTE: load capacity used for calculation $N_{rec} = 3.6 \text{ kN (axial)} / V_{rec} = 4.3 \text{ kN (shear)}$

*X-BT-MR is the new generation X-BT

[FASTENER SYSTEM](#)
[FASTENER OVERVIEW](#)
[FASTENER TECHNICAL DETAILS](#)
[APPLICATION OVERVIEW](#)
[HOW TO USE THIS DOCUMENT](#)
[DISCLAIMER](#)

FASTENING STRUT TO STEEL WITH X-BT-MR*

Two / Four X-BT-MR Threaded studs

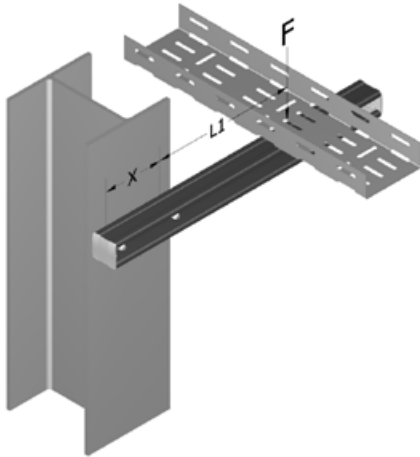

Application

- Fastening of cable trays, pipes on a horizontal cantilever support, fastened on a vertical structure
- Support is fastened by two X-BT-MR (horizontal distance x)
- L1 is the distance of the load center to the center of the fasteners
- Load F is the acceptable total load (all dead load including)

Boundary conditions

- These values are ONLY reflecting capacity of X-BT-MR threaded stud. Structural analysis of support / structure is NOT in Hilti scope. See the detailed statements in disclaimer—2018/05/04
- Shear load fully carried by one X-BT-MR (worst-case)
- Load F acting at the distance of L1 from structure surface

Technical assessment – maximum of L1 and F (depending on load F or lever arm length L1 and X-BT-MR distance x)

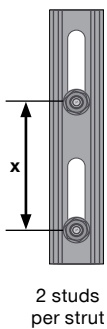

Result: L1 [mm]	F [kg]								
	50	75	100	125	150	200	250	300	
→ Load in [kN]	0.49	0.74	0.98	1.23	1.47	1.96	2.45	2.94	
x [mm]	80	620	385	270	200	150	95	60	35
	100	775	480	335	250	190	115	75	45
	125	970	605	420	310	240	145	90	55
	150	1160	725	505	375	285	175	110	65
	175	1355	845	590	435	335	205	130	80
	200	1550	965	675	500	380	235	150	90

Result: Load F [kg]	L1 [mm]								
	150	200	250	400	600	800	1000	1200	
x [mm]	80	150	125	105	70	50	35	30	25
	100	175	145	125	85	60	45	35	30
	125	195	165	145	100	75	55	45	40
	150	215	185	160	115	85	65	55	45
	175	235	200	180	130	95	75	65	55
	200	250	215	190	145	105	85	70	60

NOTE: load capacity used for calculation $N_{rec} = 3.6 \text{ kN (axial)} / V_{rec} = 4.3 \text{ kN (shear)}$

*X-BT-MR is the new generation X-BT

[FASTENER SYSTEM](#)
[FASTENER OVERVIEW](#)
[FASTENER TECHNICAL DETAILS](#)
[APPLICATION OVERVIEW](#)
[HOW TO USE THIS DOCUMENT](#)
[DISCLAIMER](#)

FASTENING T-POST (CEILING) SUPPORT WITH X-BT-MR*

Two / Four X-BT-MR Threaded studs

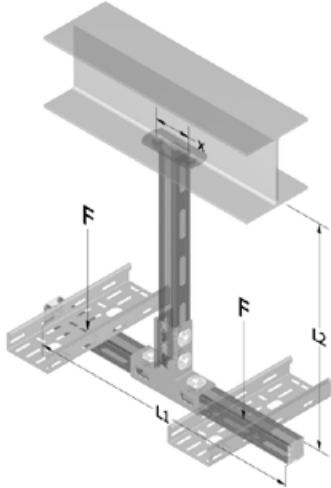

Application

- Fastening of cable trays, pipes on a T-Post support, which is fastened on a horizontal structure
- Support is fastened by two / four X-BT-MR (horizontal distance x)
- L1 is the total width of the T-Post, L2 is fix set to 1000 mm
- Load F is the acceptable total load (all dead load including)

Boundary conditions

- These values are ONLY reflecting capacity of X-BT-MR threaded stud. Structural analysis of support / structure is NOT in Hilti scope. See the detailed statements in disclaimer—2018/05/04
- 2 Load cases: load asymmetric acting in the center of one arm only, 30% acting as horizontal load

Technical assessment – maximum of L1 and F (depending on load F or lever arm length L1 and X-BT-MR distance x)

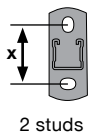

2 studs

Result: L1 [mm]	F [kg]							
	50	75	100	125	150	200	250	300
→ Load in [kN]	0.49	0.74	0.98	1.23	1.47	1.96	2.45	2.94
x [mm]	80	2185	1405					
	100	2735	1755	1265				
	125	3415	2195	1580				
	150	4100	2635	1900	1460			
	175	4785	3075	2215	1705	1360		
	200	5470	3510	2535	1945	1555		

Result: Load F [kg]	L1 [mm]							
	150	200	250	400	600	800	1000	1200
x [mm]	80	85	85	85	85	85	85	85
	100	100	100	100	100	100	100	100
	125	125	125	125	125	125	125	125
	150	145	145	145	145	145	145	145
	175	165	165	165	165	165	165	165
	200	180	180	180	180	180	180	180

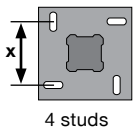

4 studs

Result: L1 [mm]	F [kg]								
	50	75	100	125	150	200	250	300	
→ Load in [kN]	0.49	0.74	0.98	1.23	1.47	1.96	2.45	2.94	
x [mm]	80	4535	2970	2185	1715	1405			
	100	5670	3710	2735	2145	1755	1265		
	125	7085	4640	3415	2685	2195	1580		
	150	8505	5570	4100	3220	2635	1900	1460	
	175	9925	6500	4785	3760	3075	2215	1705	1360
	200	11340	7425	5470	4295	3510	2535	1945	1555

Result: Load F [kg]	L1 [mm]							
	150	200	250	400	600	800	1000	1200
x [mm]	80	150	150	150	150	150	150	150
	100	180	180	180	180	180	180	180
	125	215	215	215	215	215	215	215
	150	240	240	240	240	240	240	240
	175	270	270	270	270	270	270	270
	200	290	290	290	290	290	290	290

NOTE: load capacity used for calculation $N_{rec} = 3.6$ kN (axial) / $V_{rec} = 4.3$ kN (shear)

*X-BT-MR is the new generation X-BT

[FASTENER SYSTEM](#)
[FASTENER OVERVIEW](#)
[FASTENER TECHNICAL DETAILS](#)
[APPLICATION OVERVIEW](#)
[HOW TO USE THIS DOCUMENT](#)
[DISCLAIMER](#)

FASTENING T-POST (FLOOR) SUPPORT WITH X-BT-MR*

Two / Four X-BT-MR Threaded studs

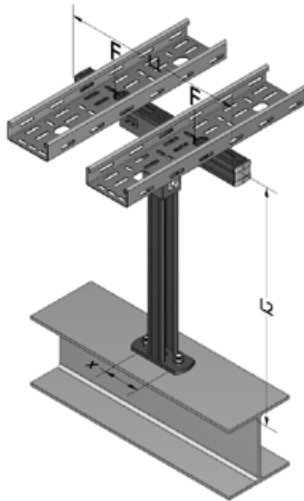

Application

- Fastening of cable trays, pipes on a T-Post support, which is fastened on a horizontal structure
- Support is fastened by two / four X-BT-MR (horizontal distance x)
- L1 is the total width of the T-Post, L2 is fix set to 1000 mm
- Load F is the acceptable total load (all dead load including)

Boundary conditions

- These values are ONLY reflecting capacity of X-BT-MR threaded stud. Structural analysis of support / structure is NOT in Hilti scope. See the detailed statements in disclaimer—2018/05/04
- 2 Load cases: load asymmetric acting in the center of one arm only, 30% acting as horizontal load

Technical assessment – maximum of L1 and F (depending on load F or lever arm length L1 and X-BT-MR distance x)

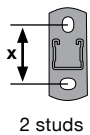

2 studs

Result: L1 [mm]	F [kg]							
	50	75	100	125	150	200	250	300
→ Load in [kN]	0.49	0.74	0.98	1.23	1.47	1.96	2.45	2.94
x [mm]	80	2505	1725					
	100	3135	2155	1665				
	125	3915	2695	2080	1715	1470		
	150	4700	3235	2500	2060	1765		
	175	5485	3775	2915	2405	2060	1630	
	200	6270	4310	3335	2745	2355	1865	

Result: Load F [kg]	L1 [mm]							
	150	200	250	400	600	800	1000	1200
x [mm]	80	95	95	95	95	95	95	95
	100	120	120	120	120	120	120	120
	125	150	150	150	150	150	150	150
	150	180	180	180	180	180	180	180
	175	210	210	210	210	210	210	210
	200	240	240	240	240	240	240	240

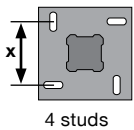

4 studs

Result: L1 [mm]	F [kg]							
	50	75	100	125	150	200	250	300
→ Load in [kN]	0.49	0.74	0.98	1.23	1.47	1.96	2.45	2.94
x [mm]	80	4855	3290					
	100	6070	4110	3135				
	125	7585	5140	3915	3185	2695		
	150	9105	6170	4700	3820	3235		
	175	10625	7200	5485	4460	3775	2915	
	200	12140	8225	6270	5095	4310	3335	

Result: Load F [kg]	L1 [mm]							
	150	200	250	400	600	800	1000	1200
x [mm]	80	195	195	195	195	195	195	195
	100	240	240	240	240	240	240	240
	125	305	305	305	305	305	305	305
	150	365	365	365	365	365	365	365
	175	425	425	425	425	425	425	425
	200	485	485	485	485	485	485	485

NOTE: load capacity used for calculation $N_{rec} = 3.6 \text{ kN}$ (axial) / $V_{rec} = 4.3 \text{ kN}$ (shear)

*X-BT-MR is the new generation X-BT

FASTENER SYSTEM	FASTENER OVERVIEW	FASTENER TECHNICAL DETAILS	APPLICATION OVERVIEW
HOW TO USE THIS DOCUMENT	DISCLAIMER		

FASTENING U-FRAME (CEILING) / TRAPEZE SUPPORT WITH X-BT-MR*

Two / Four X-BT-MR Threaded studs

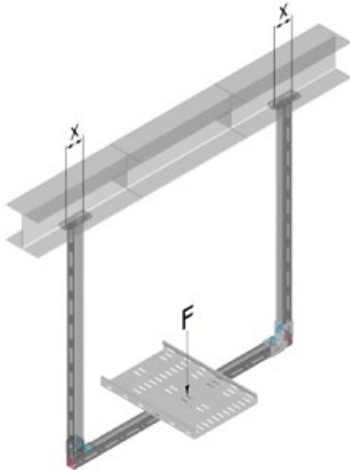

Application

- Fastening of cable trays, pipes on a U-Frame support, which is fastened on a horizontal structure
- Support is fastened by four X-BT-MR (2 fasteners per baseplate)
- Load F is the acceptable total load (all dead load including, acting in the center of the U-Frame)

Boundary conditions

- These values are ONLY reflecting capacity of X-BT-MR threaded stud. Structural analysis of support / structure is NOT in Hilti scope. See the detailed statements in disclaimer—2018/05/04
- Load acting in the center (U-Frame)

Technical assessment — maximum of F

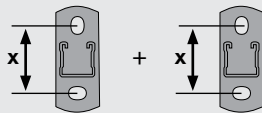
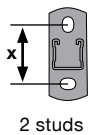

$$F = N_{rec} \cdot \text{\#fasteners per post}$$

$$F = 3.6 \text{ kN} \cdot 4$$

$$F = 14.4 \text{ kN} / F = 1470 \text{ kg}$$

NOTE: load capacity used for calculation $N_{rec} = 3.6 \text{ kN}$ (axial) / $V_{rec} = 4.3 \text{ kN}$ (shear)

*X-BT-MR is the new generation X-BT

FASTENER SYSTEM

FASTENER OVERVIEW

FASTENER TECHNICAL DETAILS

APPLICATION OVERVIEW

HOW TO USE THIS DOCUMENT

DISCLAIMER

FASTENING L-POST SUPPORT WITH X-BT-MR*

Two / Four X-BT-MR Threaded studs

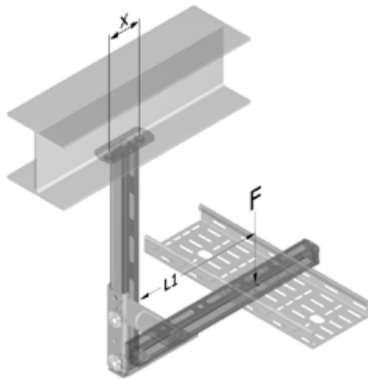

Application

- Fastening of cable trays, pipes on a L-Post support, which is fastened on a horizontal structure
- Support is fastened by two / four X-BT-MR (horizontal distance x)
- L1 is the distance of the load center to the vertical structure surface
- Load F is the acceptable total load (all dead load including)

Boundary conditions

- These values are ONLY reflecting capacity of X-BT-MR threaded stud. Structural analysis of support / structure is NOT in Hilti scope. See the detailed statements in disclaimer—2018/05/04
- Load F acting at the distance of L1 from structure surface

Technical assessment – maximum of L1 and F (depending on load F or lever arm length L1 and X-BT-MR distance x)

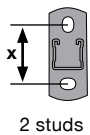

Result: L1 [mm]	F [kg]								
	50	75	100	125	150	200	250	300	
→ Load in [kN]	0.49	0.74	0.98	1.23	1.47	1.96	2.45	2.94	
x [mm]	80	545	350	250	190	155	105	75	55
	100	680	435	315	240	190	130	95	70
	125	850	545	395	300	240	165	120	90
	150	1025	655	475	365	290	200	145	105
	175	1195	765	550	425	340	230	165	125
	200	1365	875	630	485	385	265	190	140

Result: Load F [kg]	L1 [mm]								
	150	200	250	400	600	800	1000	1200	
x [mm]	80	150	120	100	65	45	30	25	20
	100	180	145	120	80	55	40	30	25
	125	215	170	145	95	65	50	40	35
	150	240	200	165	115	80	60	50	40
	175	270	220	190	130	90	70	55	45
	200	290	240	205	145	100	80	65	55

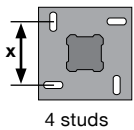

Result: L1 [mm]	F [kg]								
	50	75	100	125	150	200	250	300	
→ Load in [kN]	0.49	0.74	0.98	1.23	1.47	1.96	2.45	2.94	
x [mm]	80	1130	740	545	425	350	250	190	155
	100	1415	925	680	535	435	315	240	190
	125	1770	1160	850	670	545	395	300	240
	150	2125	1390	1025	805	655	475	365	290
	175	2480	1625	1195	940	765	550	425	340
	200	2835	1855	1365	1070	875	630	485	385

Result: Load F [kg]	L1 [mm]								
	150	200	250	400	600	800	1000	1200	
x [mm]	80	305	240	200	130	90	65	55	45
	100	365	290	240	160	110	85	65	55
	125	430	345	290	195	135	105	85	70
	150	485	400	335	230	160	125	100	85
	175	540	445	380	260	185	140	115	95
	200	585	485	415	290	205	160	130	110

NOTE: load capacity used for calculation $N_{rec} = 3.6 \text{ kN}$ (axial) / $V_{rec} = 4.3 \text{ kN}$ (shear)

*X-BT-MR is the new generation X-BT

[FASTENER SYSTEM](#)
[FASTENER OVERVIEW](#)
[FASTENER TECHNICAL DETAILS](#)
[APPLICATION OVERVIEW](#)
[HOW TO USE THIS DOCUMENT](#)
[DISCLAIMER](#)

FASTENING EQUIPMENT SUPPORT WITH X-BT-MR*

Two / Four X-BT-MR Threaded studs

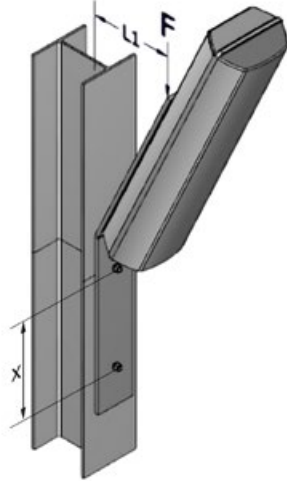

Application

- Fastening of lamps, signals, sensors on inclined cantilever support, fastened on a vertical structure
- Support is fastened by two / four X-BT-MR (vertical distance x)
- L1 is the distance of the load center (~middle of the load) to the vertical structure surface
- Load F is the acceptable total load (all dead load including)

Boundary conditions

- These values are ONLY reflecting capacity of X-BT-MR threaded stud. Structural analysis of support / structure is NOT in Hilti scope. See the detailed statements in disclaimer—2018/05/04
- Shear load fully carried by one / two top X-BT-MR (worst-case)
- Load F acting at the distance of L1 from structure surface

Technical assessment – maximum of L1 and F (depending on load F or lever arm length L1 and X-BT-MR distance x)

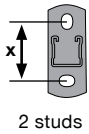

Result: L1 [mm]	F [kg]								
	50	75	100	125	150	200	250	300	
→ Load in [kN]	0.49	0.74	0.98	1.23	1.47	1.96	2.45	2.94	
x [mm]	80	585	390	285	210	165	105	70	50
	100	730	485	355	265	205	135	90	60
	125	915	610	445	335	260	170	115	75
	150	1100	730	530	400	310	200	135	90
	175	1280	855	620	470	365	235	160	110
	200	1465	975	710	535	415	270	180	125

Result: Load F [kg]	L1 [mm]								
	150	200	250	400	600	800	1000	1200	
x [mm]	80	160	130	110	70	45	35	25	20
	100	185	155	130	90	60	45	35	30
	125	215	180	155	105	75	55	45	35
	150	235	200	175	125	90	65	55	45
	175	255	220	190	140	100	80	60	50
	200	275	235	210	155	110	90	70	60

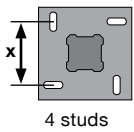

Result: L1 [mm]	F [kg]								
	50	75	100	125	150	200	250	300	
→ Load in [kN]	0.49	0.74	0.98	1.23	1.47	1.96	2.45	2.94	
x [mm]	80	1170	780	570	425	335	215	145	100
	100	1465	975	710	535	415	270	180	125
	125	1830	1220	890	670	520	340	230	155
	150	2200	1465	1065	805	625	405	275	185
	175	2565	1710	1245	940	730	475	320	220
	200	2935	1955	1425	1070	835	545	365	250

Result: Load F [kg]	L1 [mm]								
	150	200	250	400	600	800	1000	1200	
x [mm]	80	320	260	220	145	95	70	55	45
	100	375	310	260	180	120	90	70	60
	125	430	360	310	215	150	110	90	75
	150	475	405	350	250	180	135	110	90
	175	515	440	385	280	205	160	125	105
	200	550	475	420	310	225	180	145	120

NOTE: load capacity used for calculation $N_{rec} = 3.6 \text{ kN (axial)} / V_{rec} = 4.3 \text{ kN (shear)}$

*X-BT-MR is the new generation X-BT

FASTENER SYSTEM	FASTENER OVERVIEW	FASTENER TECHNICAL DETAILS	APPLICATION OVERVIEW
HOW TO USE THIS DOCUMENT	DISCLAIMER		

FASTENING JUNCTION BOXES / SWITCHES WITH X-BT-MR*

X-BT-MR Threaded stud

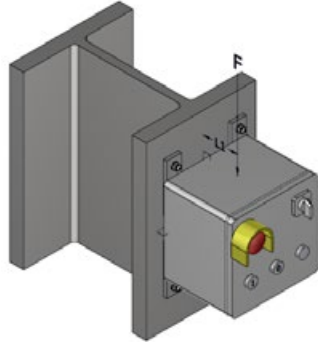

Application

- Fastening of junction boxes, switches on a vertical structure
- Element is fastened by X-BT-MR

Boundary conditions

- These values are ONLY reflecting capacity of X-BT-MR threaded stud. Structural analysis of support / structure is NOT in Hilti scope. See the detailed statements in disclaimer—2018/05/04
- Technical data are based on technical data binder for X-BT-MR (06 / 2018), always refer to latest technical data binder for X-BT-MR

Technical data — always refer to latest technical data binder for X-BT-MR

Recommended load	X-BT-MR		
Drill hole type and base material thickness	Pilot hole, $t_{II} \geq 8 \text{ mm (0.31")}$		
Base material	Steel S235 A36	Steel S355 Grade 50	Cast iron with spheroidal graphite
Tension, N_{rec} [kN / lb]	3.6 / 810	4.6 / 1030	1.0 / 230
Shear, V_{rec} [kN / lb]	4.3 / 970	5.3 / 1190	1.5 / 340
Moment, M_{rec} [Nm / ft-lb]	20.0 / 14.8	20.0 / 14.8	16.0 / 11.5

Design resistance	X-BT-MR		
Drill hole type and base material thickness	Pilot hole, $t_{II} \geq 8 \text{ mm (0.31")}$		
Base material	Steel S235 A36	Steel S355 Grade 50	Cast iron with spheroidal graphite
Tension, N_{Rd} [kN / lb]	5.0	6.5	1.6
Shear, V_{Rd} [kN / lb]	6.0	7.5	2.4
Moment, M_{Rd} [Nm / ft-lb]	28.0	28.0	26.0

Conditions for recommended loads

- Global factor of safety for static pull-out > 3 (based on 5% fractile value), ≥ 5 (based on mean value)
- Minimum edge distance = 6 mm [$\frac{1}{4}$ "]
- Effect of base metal vibration and stress considered
- Redundancy (multiple fastening) must be provided
- Recommended loads in the table refer to the resistance of the individual fastening and may not be the same as the loads F_N and F_V acting on the fastened part

Note: if relevant, prying forces need to be considered in design, see example. Moment acting on fastener shank only in case of a gap between base and fastened material.

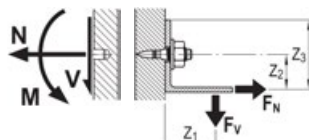

Recommended interaction formula for combined loading — steel and cast iron base material

Combined loading situation	Interaction formula
V-N (shear and tension)	$\frac{V}{V_{rec}} + \frac{N}{N_{rec}} \leq 1.2$ with $\frac{V}{V_{rec}} \leq 1.0$ and $\frac{N}{N_{rec}} \leq 1.0$
V-M (shear and bending)	$\frac{V}{V_{rec}} + \frac{M}{M_{rec}} \leq 1.2$ with $\frac{V}{V_{rec}} \leq 1.0$ and $\frac{M}{M_{rec}} \leq 1.0$
N-M (tension and bending)	$\frac{N}{N_{rec}} + \frac{M}{M_{rec}} \leq 1.0$
V-N-M (shear, tension and bending)	$\frac{V}{V_{rec}} + \frac{N}{N_{rec}} + \frac{M}{M_{rec}} \leq 1.0$

*X-BT-MR is the new generation X-BT

X-BT-MR* CATALOG PAGES

Description	Base Material	Environment	Item Number
Threaded stud X-BT-MR M8/14 SN 8	Steel	Highly corrosive	2194339
Threaded stud X-BT-MR M6/14 SN 8	Steel	Highly corrosive	2194337
Threaded stud X-BT-MR W6/14 SN 8	Steel	Highly corrosive	2194338
Threaded stud X-BT-MR M10/15 SN 8	Steel	Highly corrosive	2194340
Threaded stud X-BT-MR W10/15 SN 8	Steel	Highly corrosive	2194341

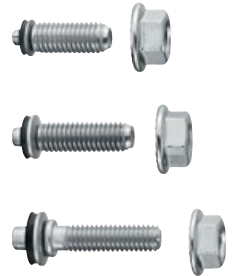

Tool Kit	Item Number
X-BT tool set*	Local item
DX 351-BT powder-actuated tool	Local item
Piston X-351 BT	378676
Fastener guide BT FG M1024 for metric studs	378674
Fastener guide BT FG W1024 for Whitworth studs	378673
6.8/11 M10 brown cartridge	412689
SF BT 22-A cordless drill	2123719



Accessories	Item Number
Stepped drill bit TX-BT 4.7/7-80	2197930
Nut setter S-NS 13C (for use with M8 flange nuts)	2149244
Socket wrench insert X-NSD 1/4" - 10 mm (for M6)	2197934
Socket wrench insert X-NSD 1/4" - 25/64" (for W6)	2197935
Nut setter S-NS 15C (for M10)	2149245
Nut setter S-NS 9/16"C95/3 3/4" (for W10)	2149246
Torque tool X-BT 1/4" 20 Nm / 14.8 ft-lb	2212510



*X-BT-MR is the new generation X-BT





S-BT-MR HL /
S-BT-MF MT HL /
S-BT-MF HL
THREADED STUD

Metric

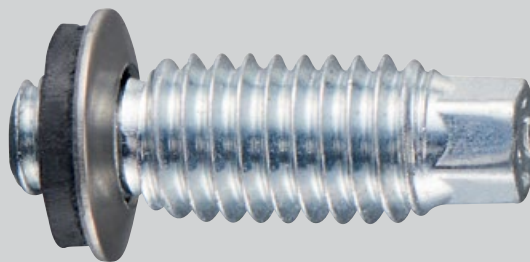

S-BT HL TECHNICAL DATA USED FOR THE FOLLOWING CALCULATIONS

S-BT HL technical data

- **Drill hole type / base material:** Pilot hole, $t_{II} \geq 6 \text{ mm (0.24")}$ or drill through hole, $5 \text{ mm (0.20")} \leq t_{II} < 6 \text{ mm (0.24")}$
- **Base material:** Steel S235 / A36 (higher steel strength is possible, increases the rec. load)

Recommended interaction for combined loads

S-BT-MR HL

$N_{rec} = 3.6\text{kN (axial)} / V_{rec} = 4.0\text{kN (shear)}$
 Washer diameter = 12 mm
 For opening > 13 mm

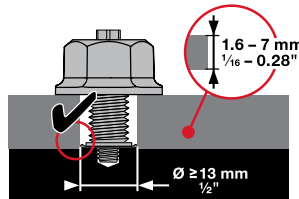

S-BT-MF MT HL

$N_{rec} = 3.6\text{kN (axial)} / V_{rec} = 4.0\text{kN (shear)}$
 Washer diameter = 12 mm
 For opening > 13 mm

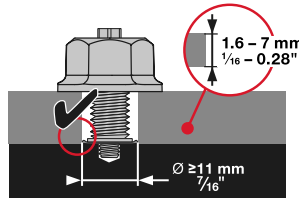

S-BT-MF HL

$N_{rec} = 3.6\text{kN (axial)} / V_{rec} = 2.75\text{kN (shear)}$
 Washer diameter = 10 mm
 For opening > 11 mm

V-N (shear and tension)

$$\frac{V}{V_{rec}} + \frac{N}{N_{rec}} \leq 1.0 \quad \text{with} \quad \frac{V}{V_{rec}} \leq 1.0 \quad \text{and} \quad \frac{N}{N_{rec}} \leq 1.0$$

For further technical data refer to the latest technical information (DFTM and S-BT HL specification binder)

FASTENING CANTILEVER SUPPORT WITH S-BT HL

Two / Four S-BT-MR HL / S-BT-MF MT HL Threaded studs

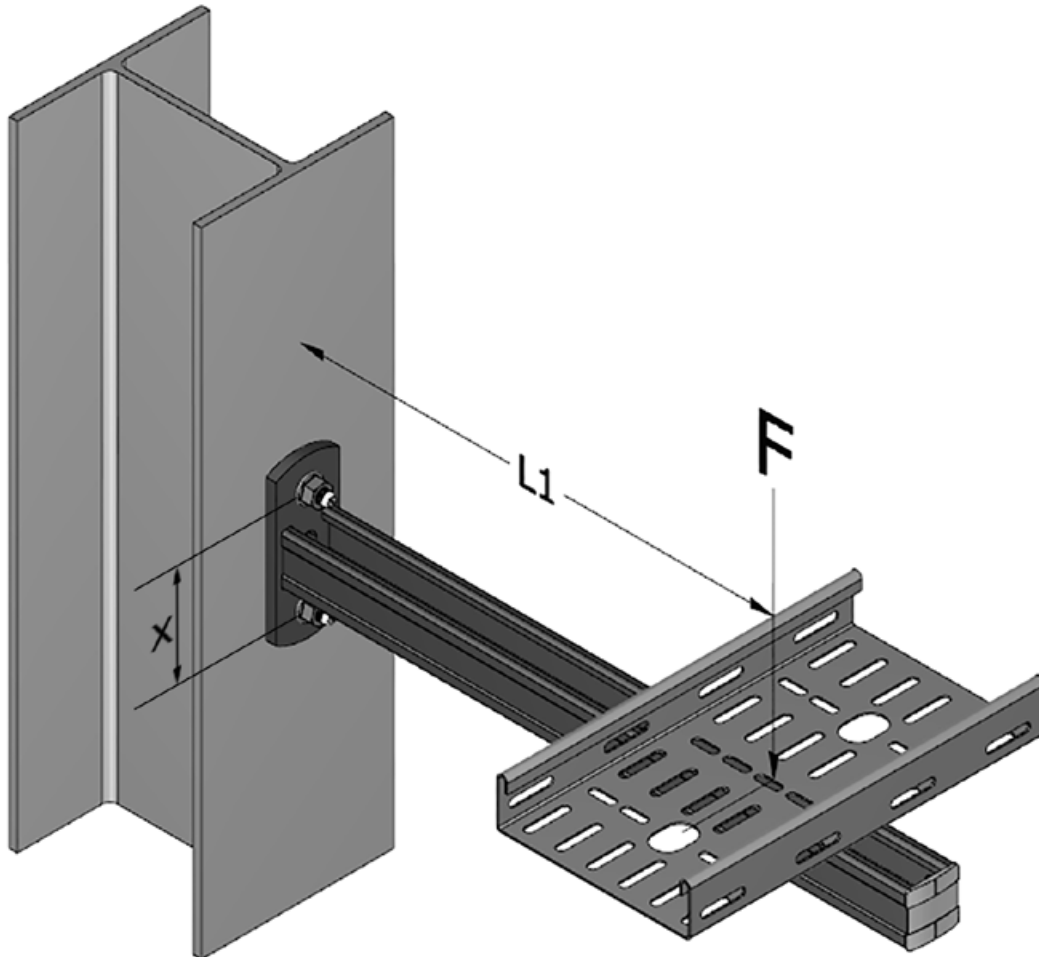

Application

- Fastening of cable trays, pipes on a horizontal cantilever support, fastened on a vertical structure
- Support is fastened by two / four S-BT HL on both support and brace baseplate with distance x
- $L1$ is the distance of the load center to the vertical structure surface
- Load F is the acceptable total load (all dead load including)

Boundary conditions

- These values are ONLY reflecting capacity of S-BT HL threaded stud. Structural analysis of support / structure is NOT in Hilti scope. See the detailed statements in disclaimer—2018/05/04
- Shear load fully carried by one / two top S-BT HL (worst-case)
- Load F acting at the distance of $L1$ from structure surface

Technical assessment – maximum of $L1$ and F (depending on load F or lever arm length $L1$ and S-BT distance x)

FASTENER SYSTEM

FASTENER OVERVIEW

FASTENER TECHNICAL DETAILS

APPLICATION OVERVIEW

HOW TO USE THIS DOCUMENT

DISCLAIMER

FASTENING CANTILEVER SUPPORT WITH S-BT HL

Two / Four S-BT-MR HL / S-BT-MF MT HL Threaded studs

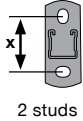

Result:		F [kg]							
L1 [mm]		50	75	100	125	150	200	250	300
→ Load in [kN]		0.49	0.74	0.98	1.23	1.47	1.96	2.45	2.94
x [mm]	80	585	390	280	205	160	100	65	45
	100	730	485	350	260	200	130	85	55
	125	915	610	435	325	250	160	105	70
	150	1100	730	525	390	305	195	125	85
	175	1280	855	610	455	355	225	150	95
	200	1465	975	700	520	405	260	170	110

Result:		L1 [mm]							
Load F [kg]		150	200	250	400	600	800	1000	1200
x [mm]	80	155	125	105	70	45	35	25	20
	100	180	150	125	85	60	45	35	30
	125	205	175	150	105	75	55	45	35
	150	230	195	170	120	85	65	55	45
	175	250	215	185	135	100	80	60	50
	200	265	230	200	150	110	85	70	60

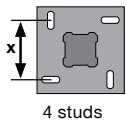

Result:		F [kg]							
L1 [mm]		50	75	100	125	150	200	250	300
→ Load in [kN]		0.49	0.74	0.98	1.23	1.47	1.96	2.45	2.94
x [mm]	80	1170	780	585	465	390	280	205	160
	100	1465	975	730	585	485	350	260	200
	125	1830	1220	915	730	610	435	325	250
	150	2200	1465	1100	880	730	525	390	305
	175	2565	1710	1280	1025	855	610	455	355
	200	2935	1955	1465	1170	975	700	520	405

Result:		L1 [mm]							
Load F [kg]		150	200	250	400	600	800	1000	1200
x [mm]	80	315	255	215	145	95	70	55	45
	100	365	300	255	175	120	90	70	60
	125	415	350	300	210	150	110	90	75
	150	460	390	340	245	175	135	110	90
	175	500	430	375	275	200	160	125	105
	200	530	460	405	300	225	175	145	120

NOTE: load capacity used for calculation $N_{rec} = 3.6\text{kN}$ (axial) / $V_{rec} = 4.0\text{kN}$ (shear)

Two / Four S-BT-MF HL Threaded studs

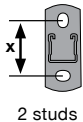

Result:		F [kg]							
L1 [mm]		50	75	100	125	150	200	250	300
→ Load in [kN]		0.49	0.74	0.98	1.23	1.47	1.96	2.45	2.94
x [mm]	80	585	360	245	175	130	70	35	
	100	730	455	305	220	160	85	45	
	125	915	570	385	275	200	110	55	
	150	1100	680	460	330	240	130	65	
	175	1280	795	540	385	280	155	75	
	200	1465	910	615	440	325	175	90	

Result:		L1 [mm]							
Load F [kg]		150	200	250	400	600	800	1000	1200
x [mm]	80	135	115	95	65	45	35	25	20
	100	155	130	115	80	60	45	35	30
	125	175	150	130	95	70	55	45	35
	150	190	165	145	110	80	65	55	45
	175	200	175	160	120	90	70	60	50
	200	210	190	170	130	100	80	65	60

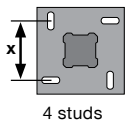

Result:		F [kg]							
L1 [mm]		50	75	100	125	150	200	250	300
→ Load in [kN]		0.49	0.74	0.98	1.23	1.47	1.96	2.45	2.94
x [mm]	80	1170	780	585	455	360	245	175	130
	100	1465	975	730	570	455	305	220	160
	125	1830	1220	915	715	570	385	275	200
	150	2200	1465	1100	860	680	460	330	240
	175	2565	1710	1280	1000	795	540	385	280
	200	2935	1955	1465	1145	910	615	440	325

Result:		L1 [mm]							
Load F [kg]		150	200	250	400	600	800	1000	1200
x [mm]	80	275	230	195	135	95	70	55	45
	100	310	265	230	165	120	90	70	60
	125	350	300	265	195	140	110	90	75
	150	380	330	295	220	165	130	110	90
	175	405	355	320	245	185	145	125	105
	200	425	380	340	265	200	165	135	120

NOTE: load capacity used for calculation $N_{rec} = 3.6\text{kN}$ (axial) / $V_{rec} = 2.75\text{kN}$ (shear)

FASTENER SYSTEM	FASTENER OVERVIEW	FASTENER TECHNICAL DETAILS	APPLICATION OVERVIEW
HOW TO USE THIS DOCUMENT	DISCLAIMER		

FASTENING BRACED CANTILEVER SUPPORT WITH S-BT HL

Two / Four S-BT-MR HL / S-BT-MF MT HL Threaded studs

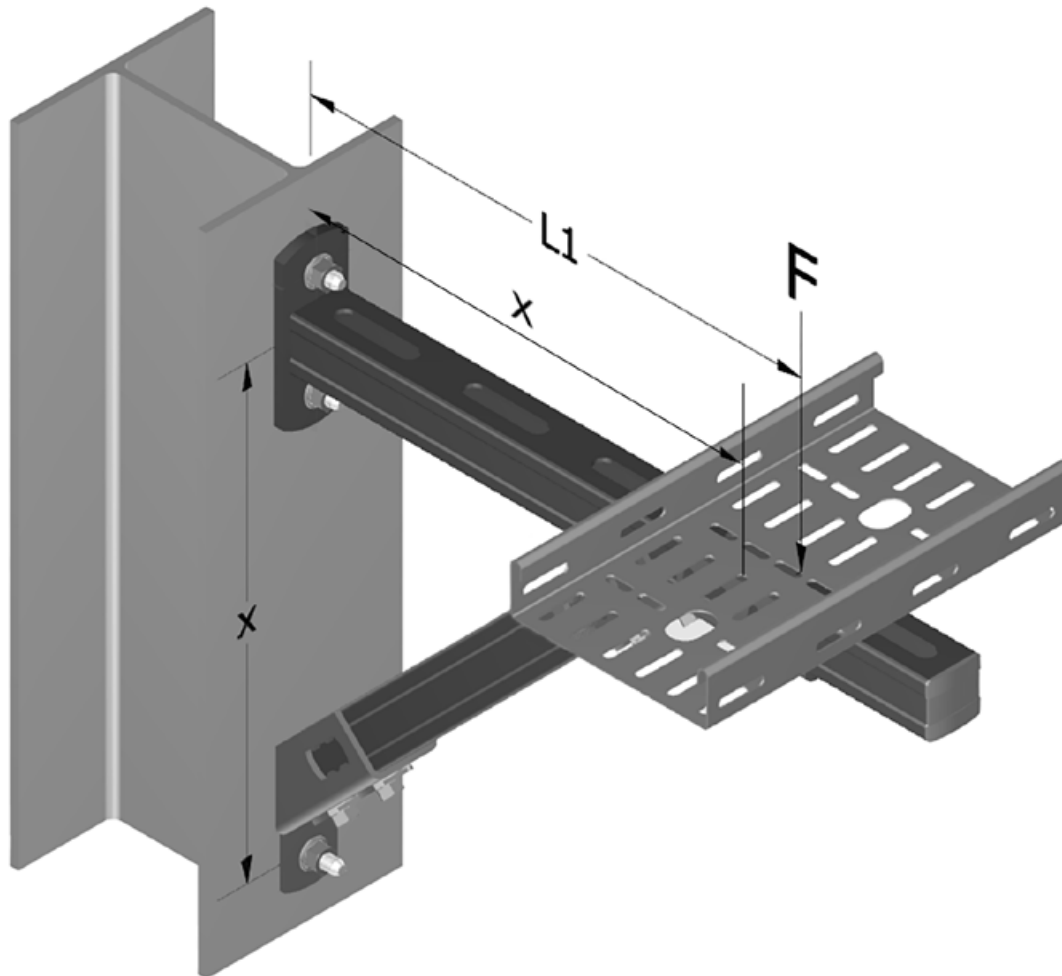

Application

- Fastening of cable trays, pipes on a horizontal, braced cantilever support, fastened on a vertical structure
- Support is fastened by three / six S-BT HL on both support and brace baseplate with distance x
- $L1$ is the distance of the load center to the vertical structure surface, the angle of the brace is 45°
- Load F is the acceptable total load (all dead load including)

Boundary conditions

- These values are ONLY reflecting capacity of S-BT HL threaded stud. Structural analysis of support / structure is NOT in Hilti scope. See the detailed statements in disclaimer—2018/05/04
- Shear load fully carried by one / two top S-BT HL (worst-case)
- Load F acting at the distance of $L1$ from structure surface

Technical assessment – maximum of $L1$ and F (depending on load F or lever arm length $L1$ and baseplate distance x)

FASTENER SYSTEM	FASTENER OVERVIEW	FASTENER TECHNICAL DETAILS	APPLICATION OVERVIEW
HOW TO USE THIS DOCUMENT	DISCLAIMER		

FASTENING BRACED CANTILEVER SUPPORT WITH S-BT HL

Two / Four S-BT-MR HL / S-BT-MF MT HL Threaded studs

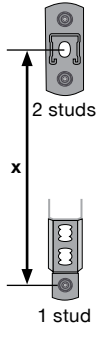

Result:		F [kg]							
L1 [mm]		50	75	100	125	150	200	250	300
→ Load in [kN]		0.49	0.74	0.98	1.23	1.47	1.96	2.45	2.94
x [mm]	80	480	375	315	270	200	160	135	
	100	725	565	470	405	305	240	200	
	125	965	755	630	540	405	325	270	
	150	1690	1325	1105	950	710	570	475	
	175	2415	1890	1575	1355	1015	815	675	
	200	3865	3030	2525	2170	1630	1300	1085	

Result:		L1 [mm]							
Load F [kg]		150	200	250	400	600	800	1000	1200
x [mm]	80	270	200	160	100	65			
	100	405	305	240	150	100			
	125	405	325	200	135				
	150			355	235				
	175				335				
	200								

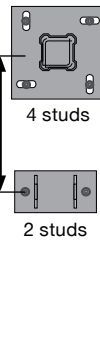

Result:		F [kg]							
L1 [mm]		50	75	100	125	150	200	250	300
→ Load in [kN]		0.49	0.74	0.98	1.23	1.47	1.96	2.45	2.94
x [mm]	80			565	480	375	315	270	
	100			850	725	565	470	405	
	125			1135	965	755	630	540	
	150			1985	1690	1325	1105	950	
	175			2835	2415	1890	1575	1355	
	200			4540	3865	3030	2525	2170	

Result:		L1 [mm]							
Load F [kg]		150	200	250	400	600	800	1000	1200
x [mm]	80	540	405	325	200	135			
	100	815	610	485	305	200	150	120	
	125		815	650	405	270	200	160	135
	150			710	475	355	285	235	
	175				675	505	405	335	
	200					815	650	540	

NOTE: load capacity used for calculation $N_{rec} = 3.6\text{kN}$ (axial) / $V_{rec} = 4.0\text{kN}$ (shear)

Two / Four S-BT-MF HL Threaded studs

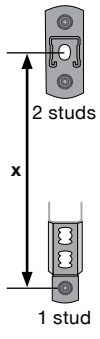

Result:		F [kg]							
L1 [mm]		50	75	100	125	150	200	250	300
→ Load in [kN]		0.49	0.74	0.98	1.23	1.47	1.96	2.45	2.94
x [mm]	80	555	370	280	220	185	140	110	
	100	835	560	420	335	280	210	165	
	125	1115	745	560	445	370	280	220	
	150	1955	1305	980	780	650	490	390	
	175	2795	1865	1400	1120	930	700	560	
	200	4470	2990	2240	1790	1495	1120	895	

Result:		L1 [mm]							
Load F [kg]		150	200	250	400	600	800	1000	1200
x [mm]	80	185	140	110	70	45			
	100	280	210	165	105	70			
	125		280	220	140	90			
	150				245	160			
	175					230			
	200								

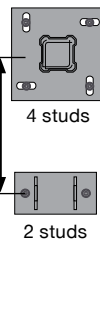

Result:		F [kg]							
L1 [mm]		50	75	100	125	150	200	250	300
→ Load in [kN]		0.49	0.74	0.98	1.23	1.47	1.96	2.45	2.94
x [mm]	80			555	445	370	280	220	185
	100			835	670	560	420	335	280
	125			1115	895	745	560	445	370
	150			1955	1565	1305	980	780	650
	175			2795	2240	1865	1400	1120	930
	200			4470	3585	2990	2240	1790	1495

Result:		L1 [mm]							
Load F [kg]		150	200	250	400	600	800	1000	1200
x [mm]	80	370	280	220	140	90			
	100	560	420	335	210	140	105	80	
	125		560	445	280	185	140	110	90
	150				490	325	245	195	160
	175					465	350	280	230
	200						560	445	370

NOTE: load capacity used for calculation $N_{rec} = 3.6\text{kN}$ (axial) / $V_{rec} = 2.75\text{kN}$ (shear)

FASTENER SYSTEM	FASTENER OVERVIEW	FASTENER TECHNICAL DETAILS	APPLICATION OVERVIEW
HOW TO USE THIS DOCUMENT	DISCLAIMER		

FASTENING STRUT TO STEEL WITH S-BT HL

Two S-BT-MR HL / S-BT-MF MT HL Threaded studs

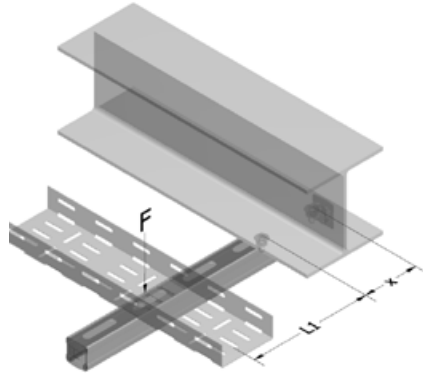

Application

- Fastening of cable trays, pipes on a horizontal cantilever support, fastened on a horizontal structure
- Support is fastened by two S-BT HL (horizontal distance x)
- L1 is the distance of the load center to the vertical structure surface
- Load F is the acceptable total load (all dead load including)

Boundary conditions

- These values are ONLY reflecting capacity of S-BT HL threaded stud. Structural analysis of support / structure is NOT in Hilti scope. See the detailed statements in disclaimer—2018/05/04
- Load F acting at the distance of L1 from structure surface

S-BT-MR HL / S-BT-MF MT HL

Technical assessment – maximum of L1 and F (depending on load F or lever arm length L1 and S-BT distance x)

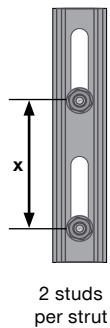

Result: L1 [mm]	F [kg]								
	50	75	100	125	150	200	250	300	
→ Load in [kN]	0.49	0.74	0.98	1.23	1.47	1.96	2.45	2.94	
x [mm]	80	505	310	210	150	115	65	35	15
	100	630	385	265	190	140	80	45	20
	125	790	485	330	240	180	100	55	25
	150	950	580	400	290	215	125	70	30
	175	1105	680	465	335	250	145	80	35
	200	1265	775	530	385	285	165	90	40

Result: Load F [kg]	L1 [mm]								
	150	200	250	400	600	800	1000	1200	
x [mm]	80	125	100	85	60	40	30	25	20
	100	145	120	100	70	50	40	30	25
	125	165	140	120	85	60	45	40	30
	150	180	155	135	100	70	55	45	40
	175	195	170	150	110	80	65	50	45
	200	205	180	160	120	90	70	60	50

NOTE: load capacity used for calculation $N_{rec} = 3.6\text{kN}$ (axial) / $V_{rec} = 4.0\text{kN}$ (shear)

Two S-BT-MF HL Threaded studs

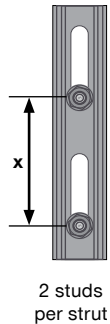

Result: L1 [mm]	F [kg]								
	50	75	100	125	150	200	250	300	
→ Load in [kN]	0.49	0.74	0.98	1.23	1.47	1.96	2.45	2.94	
x [mm]	80	505	310	210	150	115	65	35	15
	100	630	385	265	190	140	80	45	20
	125	790	485	330	240	180	100	55	25
	150	950	580	400	290	215	125	70	30
	175	1105	680	465	335	250	145	80	35
	200	1265	775	530	385	285	165	90	40

Result: Load F [kg]	L1 [mm]								
	150	200	250	400	600	800	1000	1200	
x [mm]	80	125	100	85	60	40	30	25	20
	100	145	120	100	70	50	40	30	25
	125	165	140	120	85	60	45	40	30
	150	180	155	135	100	70	55	45	40
	175	195	170	150	110	80	65	50	45
	200	205	180	160	120	90	70	60	50

NOTE: load capacity used for calculation $N_{rec} = 3.6\text{kN}$ (axial) / $V_{rec} = 2.75\text{kN}$ (shear)

[FASTENER SYSTEM](#)
[FASTENER OVERVIEW](#)
[FASTENER TECHNICAL DETAILS](#)
[APPLICATION OVERVIEW](#)
[HOW TO USE THIS DOCUMENT](#)
[DISCLAIMER](#)

FASTENING STRUT TO STEEL WITH S-BT HL

Two / Four S-BT-MR HL / S-BT-MF MT HL Threaded studs

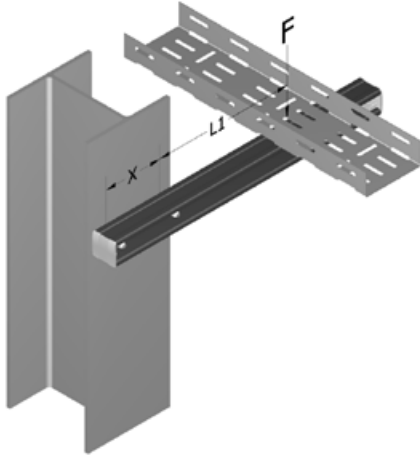

Application

- Fastening of cable trays, pipes on a horizontal cantilever support, fastened on a vertical structure
- Support is fastened by two S-BT HL (horizontal distance x)
- L1 is the distance of the load center to the center of the fasteners
- Load F is the acceptable total load (all dead load including)

Boundary conditions

- These values are ONLY reflecting capacity of S-BT HL threaded stud. Structural analysis of support / structure is NOT in Hilti scope. See the detailed statements in disclaimer—2018/05/04
- Shear load fully carried by one S-BT HL (worst-case)
- Load F acting at the distance of L1 from structure surface

S-BT-MR HL / S-BT-MF MT HL

Technical assessment – maximum of L1 and F (depending on load F or lever arm length L1 and S-BT distance x)

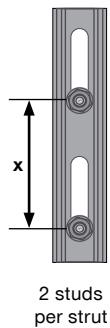

Result:		F [kg]							
L1 [mm]		50	75	100	125	150	200	250	300
→ Load in [kN]		0.49	0.74	0.98	1.23	1.47	1.96	2.45	2.94
x [mm]	80	570	350	245	180	135	80	50	25
	100	715	440	305	225	170	100	60	35
	125	890	550	380	280	210	125	75	40
	150	1070	665	460	335	255	155	90	50
	175	1250	775	535	395	300	180	110	60
	200	1430	885	615	450	340	205	125	70

Result:		L1 [mm]							
Load F [kg]		150	200	250	400	600	800	1000	1200
x [mm]	80	140	115	95	65	45	35	30	25
	100	160	135	115	80	55	45	35	30
	125	185	155	135	95	70	55	45	35
	150	200	170	150	110	80	60	50	45
	175	215	190	165	120	90	70	60	50
	200	230	200	180	135	100	80	65	55

NOTE: load capacity used for calculation $N_{rec} = 3.6\text{kN}$ (axial) / $V_{rec} = 4.0\text{kN}$ (shear)

Two S-BT-MF HL Threaded studs

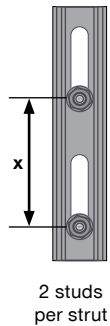

Result:		F [kg]							
L1 [mm]		50	75	100	125	150	200	250	300
→ Load in [kN]		0.49	0.74	0.98	1.23	1.47	1.96	2.45	2.94
x [mm]	80	365	215	140	95	65	30	5	
	100	460	270	180	120	85	40	10	
	125	575	340	225	155	105	50	15	
	150	690	410	270	185	130	60	15	
	175	805	475	315	215	150	70	20	
	200	920	545	360	245	170	80	20	

Result:		L1 [mm]							
Load F [kg]		150	200	250	400	600	800	1000	1200
x [mm]	80	95	80	65	45	30	25	20	15
	100	110	90	80	55	40	30	25	20
	125	125	105	90	65	45	35	30	25
	150	140	120	105	75	55	40	35	30
	175	150	130	115	85	60	50	40	35
	200	160	140	120	90	70	55	45	40

NOTE: load capacity used for calculation $N_{rec} = 3.6\text{kN}$ (axial) / $V_{rec} = 2.75\text{kN}$ (shear)

[FASTENER SYSTEM](#)
[FASTENER OVERVIEW](#)
[FASTENER TECHNICAL DETAILS](#)
[APPLICATION OVERVIEW](#)
[HOW TO USE THIS DOCUMENT](#)
[DISCLAIMER](#)

FASTENING T-POST (CEILING) SUPPORT WITH S-BT HL

Two / Four S-BT-MR HL / S-BT-MF MT HL Threaded studs

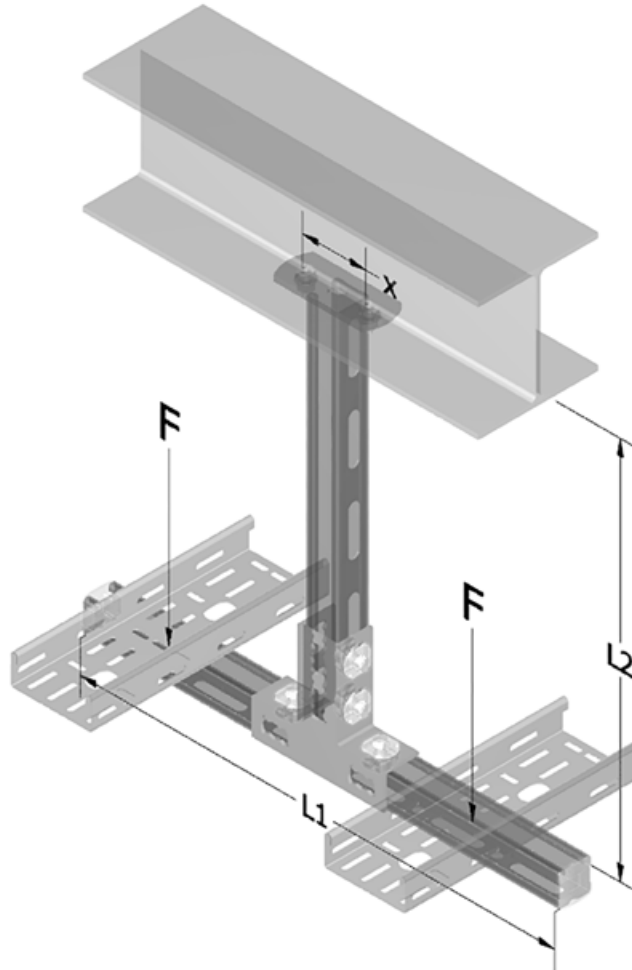

Application

- Fastening of cable trays, pipes on a T-Post support, which is fastened on a horizontal structure
- Support is fastened by two / four S-BT HL (horizontal distance x)
- $L1$ is the total width of the T-Post, $L2$ is fix set to 1000 mm
- Load F is the acceptable total load (all dead load including)

Boundary conditions

- These values are ONLY reflecting capacity of S-BT HL threaded stud. Structural analysis of support / structure is NOT in Hilti scope. See the detailed statements in disclaimer—2018/05/04
- 2 Load cases: load asymmetric acting in the center of one arm only, 30% acting as horizontal load

Technical assessment – maximum of $L1$ and F (depending on load F or lever arm length $L1$ and S-BT distance x)

FASTENER SYSTEM

FASTENER OVERVIEW

FASTENER TECHNICAL DETAILS

APPLICATION OVERVIEW

HOW TO USE THIS DOCUMENT

DISCLAIMER

FASTENING T-POST (CEILING) SUPPORT WITH S-BT HL

Two / Four S-BT-MR HL / S-BT-MF MT HL Threaded studs



2 studs

Result:		F [kg]							
L1 [mm]		50	75	100	125	150	200	250	300
→ Load in [kN]									
	80	2185	1405						
	100	2735	1755	1265					
x [mm]	125	3415	2195	1580					
	150	4100	2635	1900	1460				
	175	4785	3075	2215	1705	1360			
	200	5470	3510	2535	1945	1555			

Result:		L1 [mm]							
Load F [kg]		150	200	250	400	600	800	1000	1200
	80	85	85	85	85	85	85	85	85
	100	100	100	100	100	100	100	100	100
x [mm]	125	125	125	125	125	125	125	125	125
	150	145	145	145	145	145	145	145	145
	175	165	165	165	165	165	165	165	165
	200	180	180	180	180	180	180	180	180

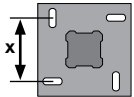

4 studs

Result:		F [kg]							
L1 [mm]		50	75	100	125	150	200	250	300
→ Load in [kN]									
	80	4535	2970	2185	1715	1405			
	100	5670	3710	2735	2145	1755	1265		
x [mm]	125	7085	4640	3415	2685	2195	1580		
	150	8505	5570	4100	3220	2635	1900	1460	
	175	9925	6500	4785	3760	3075	2215	1705	1360
	200	11340	7425	5470	4295	3510	2535	1945	1555

Result:		L1 [mm]							
Load F [kg]		150	200	250	400	600	800	1000	1200
	80	150	150	150	150	150	150	150	150
	100	180	180	180	180	180	180	180	180
x [mm]	125	215	215	215	215	215	215	215	215
	150	240	240	240	240	240	240	240	240
	175	270	270	270	270	270	270	270	270
	200	290	290	290	290	290	290	290	290

NOTE: load capacity used for calculation $N_{rec} = 3.6 \text{ kN}$ (axial) / $V_{rec} = 4.0 \text{ kN}$ (shear)

Two / Four S-BT-MF HL Threaded studs



2 studs

Result:		F [kg]							
L1 [mm]		50	75	100	125	150	200	250	300
→ Load in [kN]									
	80	2185	1405						
	100	2735	1755	1265					
x [mm]	125	3415	2195	1580					
	150	4100	2635	1900	1460				
	175	4785	3075	2215	1705	1360			
	200	5470	3510	2535	1945	1555			

Result:		L1 [mm]							
Load F [kg]		150	200	250	400	600	800	1000	1200
	80	85	85	85	85	85	85	85	85
	100	100	100	100	100	100	100	100	100
x [mm]	125	125	125	125	125	125	125	125	125
	150	145	145	145	145	145	145	145	145
	175	165	165	165	165	165	165	165	165
	200	180	180	180	180	180	180	180	180

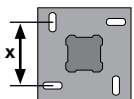

4 studs

Result:		F [kg]							
L1 [mm]		50	75	100	125	150	200	250	300
→ Load in [kN]									
	80	4535	2970	2185	1715	1405			
	100	5670	3710	2735	2145	1755	1265		
x [mm]	125	7085	4640	3415	2685	2195	1580		
	150	8505	5570	4100	3220	2635	1900	1460	
	175	9925	6500	4785	3760	3075	2215	1705	1360
	200	11340	7425	5470	4295	3510	2535	1945	1555

Result:		L1 [mm]							
Load F [kg]		150	200	250	400	600	800	1000	1200
	80	150	150	150	150	150	150	150	150
	100	180	180	180	180	180	180	180	180
x [mm]	125	215	215	215	215	215	215	215	215
	150	240	240	240	240	240	240	240	240
	175	270	270	270	270	270	270	270	270
	200	290	290	290	290	290	290	290	290

NOTE: load capacity used for calculation $N_{rec} = 3.6 \text{ kN}$ (axial) / $V_{rec} = 2.75 \text{ kN}$ (shear)

FASTENER SYSTEM	FASTENER OVERVIEW	FASTENER TECHNICAL DETAILS	APPLICATION OVERVIEW
HOW TO USE THIS DOCUMENT	DISCLAIMER		

FASTENING T-POST (FLOOR) SUPPORT WITH S-BT HL

Two / Four S-BT-MR HL / S-BT-MF MT HL Threaded studs

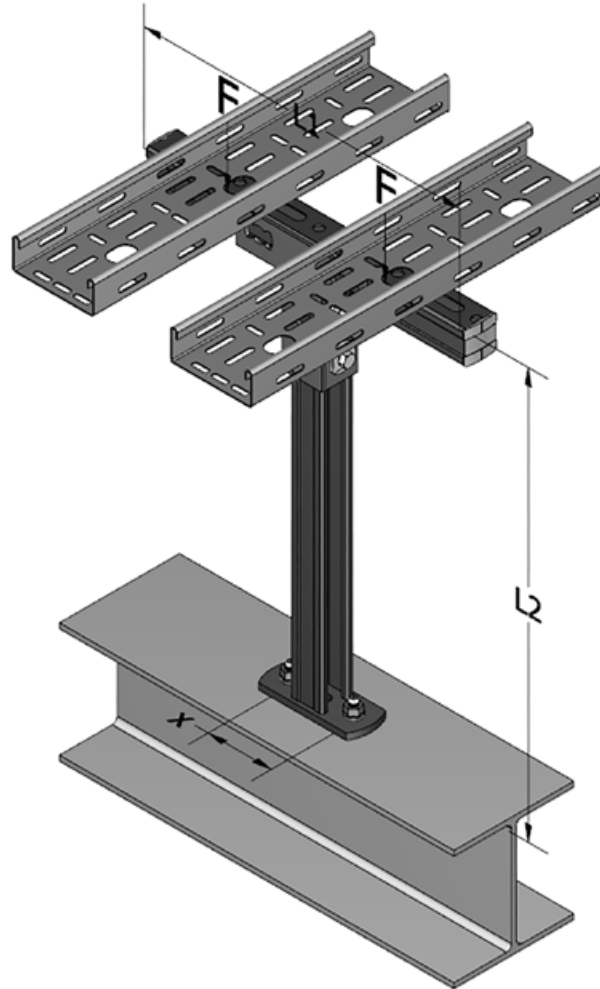

Application

- Fastening of cable trays, pipes on a T-Post support, which is fastened on a horizontal structure
- Support is fastened by two / four S-BT HL (horizontal distance x)
- $L1$ is the total width of the T-Post, $L2$ is fix set to 1000 mm
- Load F is the acceptable total load (all dead load including)

Boundary conditions

- These values are ONLY reflecting capacity of S-BT HL threaded stud. Structural analysis of support / structure is NOT in Hilti scope. See the detailed statements in disclaimer—2018/05/04
- 2 Load cases: load asymmetric acting in the center of one arm only, 30% acting as horizontal load

Technical assessment – maximum of $L1$ and F (depending on load F or lever arm length $L1$ and S-BT distance x)

FASTENER SYSTEM

FASTENER OVERVIEW

FASTENER TECHNICAL DETAILS

APPLICATION OVERVIEW

HOW TO USE THIS DOCUMENT

DISCLAIMER

FASTENING T-POST (FLOOR) SUPPORT WITH S-BT HL

Two / Four S-BT-MR HL / S-BT-MF MT HL Threaded studs



2 studs

Result:		F [kg]							
L1 [mm]		50	75	100	125	150	200	250	300
→ Load in [kN]		0.49	0.74	0.98	1.23	1.47	1.96	2.45	2.94
x [mm]	80	2505	1725						
	100	3135	2155	1665					
	125	3915	2695	2080	1715	1470			
	150	4700	3235	2500	2060	1765			
	175	5485	3775	2915	2405	2060	1630		
	200	6270	4310	3335	2745	2355	1865		

Result:		L1 [mm]							
Load		150	200	250	400	600	800	1000	1200
F [kg]		150	200	250	400	600	800	1000	1200
x [mm]	80	95	95	95	95	95	95	95	95
	100	120	120	120	120	120	120	120	120
	125	150	150	150	150	150	150	150	150
	150	180	180	180	180	180	180	180	180
	175	210	210	210	210	210	210	210	210
	200	240	240	240	240	240	240	240	240

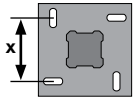

4 studs

Result:		F [kg]							
L1 [mm]		50	75	100	125	150	200	250	300
→ Load in [kN]		0.49	0.74	0.98	1.23	1.47	1.96	2.45	2.94
x [mm]	80	4855	3290						
	100	6070	4110	3135					
	125	7585	5140	3915	3185	2695			
	150	9105	6170	4700	3820	3235			
	175	10625	7200	5485	4460	3775	2915		
	200	12140	8225	6270	5095	4310	3335		

Result:		L1 [mm]							
Load		150	200	250	400	600	800	1000	1200
F [kg]		150	200	250	400	600	800	1000	1200
x [mm]	80	195	195	195	195	195	195	195	195
	100	240	240	240	240	240	240	240	240
	125	305	305	305	305	305	305	305	305
	150	365	365	365	365	365	365	365	365
	175	425	425	425	425	425	425	425	425
	200	485	485	485	485	485	485	485	485

NOTE: load capacity used for calculation $N_{rec} = 3.6$ kN (axial) / $V_{rec} = 4.0$ kN (shear)

Two / Four S-BT-MF HL Threaded studs



2 studs

Result:		F [kg]							
L1 [mm]		50	75	100	125	150	200	250	300
→ Load in [kN]		0.49	0.74	0.98	1.23	1.47	1.96	2.45	2.94
x [mm]	80	2505	1725						
	100	3135	2155	1665					
	125	3915	2695	2080	1715	1470			
	150	4700	3235	2500	2060	1765			
	175	5485	3775	2915	2405	2060	1630		
	200	6270	4310	3335	2745	2355	1865		

Result:		L1 [mm]							
Load		150	200	250	400	600	800	1000	1200
F [kg]		150	200	250	400	600	800	1000	1200
x [mm]	80	95	95	95	95	95	95	95	95
	100	120	120	120	120	120	120	120	120
	125	150	150	150	150	150	150	150	150
	150	180	180	180	180	180	180	180	180
	175	205	205	205	205	205	205	205	205
	200	230	230	230	230	230	230	230	230

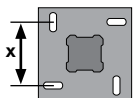

4 studs

Result:		F [kg]							
L1 [mm]		50	75	100	125	150	200	250	300
→ Load in [kN]		0.49	0.74	0.98	1.23	1.47	1.96	2.45	2.94
x [mm]	80	4855	3290						
	100	6070	4110	3135					
	125	7585	5140	3915	3185	2695			
	150	9105	6170	4700	3820	3235			
	175	10625	7200	5485	4460	3775	2915		
	200	12140	8225	6270	5095	4310	3335		

Result:		L1 [mm]							
Load		150	200	250	400	600	800	1000	1200
F [kg]		150	200	250	400	600	800	1000	1200
x [mm]	80	195	195	195	195	195	195	195	195
	100	240	240	240	240	240	240	240	240
	125	305	305	305	305	305	305	305	305
	150	365	365	365	365	365	365	365	365
	175	415	415	415	415	415	415	415	415
	200	465	465	465	465	465	465	465	465

NOTE: load capacity used for calculation $N_{rec} = 3.6$ kN (axial) / $V_{rec} = 2.75$ kN (shear)

FASTENER SYSTEM	FASTENER OVERVIEW	FASTENER TECHNICAL DETAILS	APPLICATION OVERVIEW
HOW TO USE THIS DOCUMENT	DISCLAIMER		

FASTENING U-FRAME (CEILING) / TRAPEZE SUPPORT WITH S-BT HL

Two / Four S-BT-MR HL / S-BT-MF MT HL Threaded studs

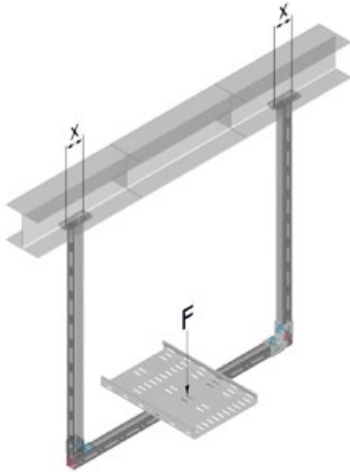

Application

- Fastening of cable trays, pipes on a U-Frame support, which is fastened on a horizontal structure
- Support is fastened by four S-BT HL (2 fasteners per baseplate)
- Load F is the acceptable total load (all dead load including, acting in the center of the U-Frame)

Boundary conditions

- These values are ONLY reflecting capacity of S-BT HL threaded stud. Structural analysis of support / structure is NOT in Hilti scope. See the detailed statements in disclaimer—2018/05/04
- Load acting in the center (U-Frame)

Two / Four S-BT-MR HL / S-BT-MF MT HL / S-BT-MF HL Threaded studs

Technical assessment — maximum of F

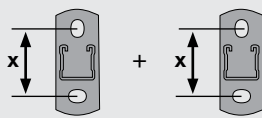
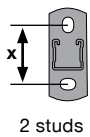

$$F = N_{rec} \cdot \text{\#fasteners per post}$$

$$F = 3.6 \text{ kN} \cdot 4$$

$$F = 14.4 \text{ kN} / F = 1460 \text{ kg}$$

NOTE: load capacity used for calculation $N_{rec} = 3.6 \text{ kN}$ (shear)

FASTENER SYSTEM

FASTENER OVERVIEW

FASTENER TECHNICAL DETAILS

APPLICATION OVERVIEW

HOW TO USE THIS DOCUMENT

DISCLAIMER

FASTENING L-POST SUPPORT WITH S-BT HL

Two / Four S-BT-MR HL / S-BT-MF MT HL Threaded studs

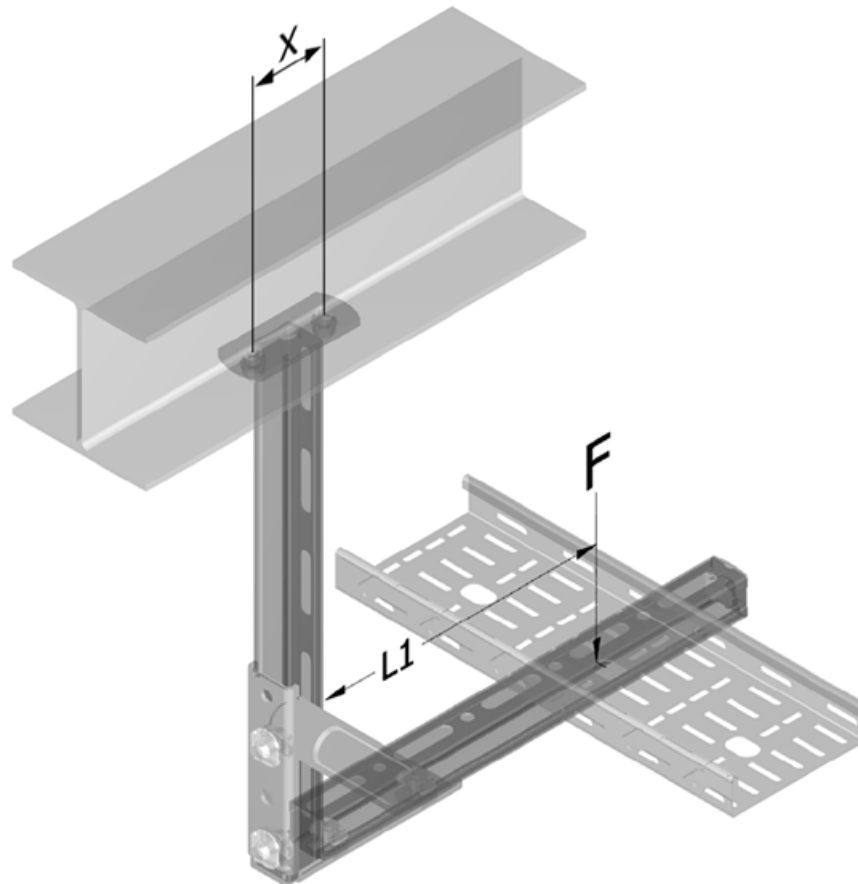

Application

- Fastening of cable trays, pipes on a L-Post support, which is fastened on a horizontal structure
- Support is fastened by two / four S-BT HL (horizontal distance x)
- $L1$ is the distance of the load center to the vertical structure surface
- Load F is the acceptable total load (all dead load including)

Boundary conditions

- These values are ONLY reflecting capacity of S-BT HL threaded stud. Structural analysis of support / structure is NOT in Hilti scope. See the detailed statements in disclaimer—2018/05/04
- Load F acting at the distance of $L1$ from structure surface

Technical assessment – maximum of $L1$ and F (depending on load F or lever arm length $L1$ and S-BT distance x)

FASTENER SYSTEM

FASTENER OVERVIEW

FASTENER TECHNICAL DETAILS

APPLICATION OVERVIEW

HOW TO USE THIS DOCUMENT

DISCLAIMER

FASTENING L-POST SUPPORT WITH S-BT HL

Two / Four S-BT-MR HL / S-BT-MF MT HL Threaded studs



Result:		F [kg]							
L1 [mm]		50	75	100	125	150	200	250	300
→ Load in [kN]		0.49	0.74	0.98	1.23	1.47	1.96	2.45	2.94
x [mm]	80	545	350	250	190	155	105	75	55
	100	680	435	315	240	190	130	95	70
	125	850	545	395	300	240	165	120	90
	150	1025	655	475	365	290	200	145	105
	175	1195	765	550	425	340	230	165	125
	200	1365	875	630	485	385	265	190	140

Result:		L1 [mm]							
Load F [kg]		150	200	250	400	600	800	1000	1200
x [mm]	80	150	120	100	65	45	30	25	20
	100	180	145	120	80	55	40	30	25
	125	215	170	145	95	65	50	40	35
	150	240	200	165	115	80	60	50	40
	175	270	220	190	130	90	70	55	45
	200	290	240	205	145	100	80	65	55



Result:		F [kg]							
L1 [mm]		50	75	100	125	150	200	250	300
→ Load in [kN]		0.49	0.74	0.98	1.23	1.47	1.96	2.45	2.94
x [mm]	80	1130	740	545	425	350	250	190	155
	100	1415	925	680	535	435	315	240	190
	125	1770	1160	850	670	545	395	300	240
	150	2125	1390	1025	805	655	475	365	290
	175	2480	1625	1195	940	765	550	425	340
	200	2835	1855	1365	1070	875	630	485	385

Result:		L1 [mm]							
Load F [kg]		150	200	250	400	600	800	1000	1200
x [mm]	80	305	240	200	130	90	65	55	45
	100	365	290	240	160	110	85	65	55
	125	430	345	290	195	135	105	85	70
	150	485	400	335	230	160	125	100	85
	175	540	445	380	260	185	140	115	95
	200	585	485	415	290	205	160	130	110

NOTE: load capacity used for calculation $N_{rec} = 3.6\text{kN}$ (axial) / $V_{rec} = 4.0\text{kN}$ (shear)

Two / Four S-BT-MF MT HL Threaded studs



Result:		F [kg]							
L1 [mm]		50	75	100	125	150	200	250	300
→ Load in [kN]		0.49	0.74	0.98	1.23	1.47	1.96	2.45	2.94
x [mm]	80	545	350	250	190	155	105	75	55
	100	680	435	315	240	190	130	95	70
	125	850	545	395	300	240	165	120	90
	150	1025	655	475	365	290	200	145	105
	175	1195	765	550	425	340	230	165	125
	200	1365	875	630	485	385	265	190	140

Result:		L1 [mm]							
Load F [kg]		150	200	250	400	600	800	1000	1200
x [mm]	80	150	120	100	65	45	30	25	20
	100	180	145	120	80	55	40	30	25
	125	215	170	145	95	65	50	40	35
	150	240	200	165	115	80	60	50	40
	175	270	220	190	130	90	70	55	45
	200	290	240	205	145	100	80	65	55



Result:		F [kg]							
L1 [mm]		50	75	100	125	150	200	250	300
→ Load in [kN]		0.49	0.74	0.98	1.23	1.47	1.96	2.45	2.94
x [mm]	80	1130	740	545	425	350	250	190	155
	100	1415	925	680	535	435	315	240	190
	125	1770	1160	850	670	545	395	300	240
	150	2125	1390	1025	805	655	475	365	290
	175	2480	1625	1195	940	765	550	425	340
	200	2835	1855	1365	1070	875	630	485	385

Result:		L1 [mm]							
Load F [kg]		150	200	250	400	600	800	1000	1200
x [mm]	80	305	240	200	130	90	65	55	45
	100	365	290	240	160	110	85	65	55
	125	430	345	290	195	135	105	85	70
	150	485	400	335	230	160	125	100	85
	175	540	445	380	260	185	140	115	95
	200	585	485	415	290	205	160	130	110

NOTE: load capacity used for calculation $N_{rec} = 3.6\text{ kN}$ (axial) / $V_{rec} = 2.75\text{ kN}$ (shear)

FASTENER SYSTEM	FASTENER OVERVIEW	FASTENER TECHNICAL DETAILS	APPLICATION OVERVIEW
HOW TO USE THIS DOCUMENT	DISCLAIMER		

FASTENING EQUIPMENT SUPPORT WITH S-BT HL

Two / Four S-BT-MR HL / S-BT-MF MT HL Threaded studs

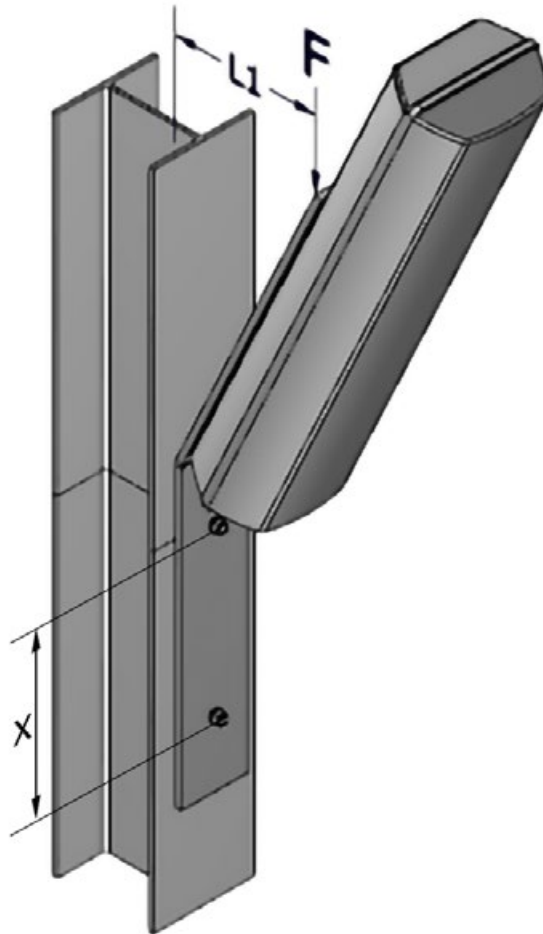

Application

- Fastening of lamps, signals, sensors on inclined cantilever support, fastened on a vertical structure
- Support is fastened by two / four S-BT HL (vertical distance x)
- L_1 is the distance of the load center (~middle of the load) to the vertical structure surface
- Load F is the acceptable total load (all dead load including)

Boundary conditions

- These values are ONLY reflecting capacity of S-BT HL threaded stud. Structural analysis of support / structure is NOT in Hilti scope. See the detailed statements in disclaimer—2018/05/04
- Shear load fully carried by one / two top S-BT HL (worst-case)
- Load F acting at the distance of L_1 from structure surface

Technical assessment – maximum of L_1 and F (depending on load F or lever arm length L_1 and S-BT distance x)

FASTENER SYSTEM

FASTENER OVERVIEW

FASTENER TECHNICAL DETAILS

APPLICATION OVERVIEW

HOW TO USE THIS DOCUMENT

DISCLAIMER

FASTENING EQUIPMENT SUPPORT WITH S-BT HL

Two / Four S-BT-MR HL / S-BT-MF MT HL Threaded studs



Result:		F [kg]							
L1 [mm]		50	75	100	125	150	200	250	300
→ Load in [kN]		0.49	0.74	0.98	1.23	1.47	1.96	2.45	2.94
x [mm]	80	585	390	280	205	160	100	65	45
	100	730	485	350	260	200	130	85	55
	125	915	610	435	325	250	160	105	70
	150	1100	730	525	390	305	195	125	85
	175	1280	855	610	455	355	225	150	95
	200	1465	975	700	520	405	260	170	110

Result:		L1 [mm]							
Load F [kg]		150	200	250	400	600	800	1000	1200
x [mm]	80	155	125	105	70	45	35	25	20
	100	180	150	125	85	60	45	35	30
	125	205	175	150	105	75	55	45	35
	150	230	195	170	120	85	65	55	45
	175	250	215	185	135	100	80	60	50
	200	265	230	200	150	110	85	70	60



Result:		F [kg]							
L1 [mm]		50	75	100	125	150	200	250	300
→ Load in [kN]		0.49	0.74	0.98	1.23	1.47	1.96	2.45	2.94
x [mm]	80	1170	780	585	465	390	280	205	160
	100	1465	975	730	585	485	350	260	200
	125	1830	1220	915	730	610	435	325	250
	150	2200	1465	1100	880	730	525	390	305
	175	2565	1710	1280	1025	855	610	455	355
	200	2935	1955	1465	1170	975	700	520	405

Result:		L1 [mm]							
Load F [kg]		150	200	250	400	600	800	1000	1200
x [mm]	80	315	255	215	145	95	70	55	45
	100	365	300	255	175	120	90	70	60
	125	415	350	300	210	150	110	90	75
	150	460	390	340	245	175	135	110	90
	175	500	430	375	275	200	160	125	105
	200	530	460	405	300	225	175	145	120

NOTE: load capacity used for calculation $N_{rec} = 3.6 \text{ kN (axial)} / V_{rec} = 4.0 \text{ kN (shear)}$

Two / Four S-BT-MF HL Threaded studs



Result:		F [kg]							
L1 [mm]		50	75	100	125	150	200	250	300
→ Load in [kN]		0.49	0.74	0.98	1.23	1.47	1.96	2.45	2.94
x [mm]	80	585	360	245	175	130	70	35	
	100	730	455	305	220	160	85	45	
	125	915	570	385	275	200	110	55	
	150	1100	680	460	330	240	130	65	
	175	1280	795	540	385	280	155	75	
	200	1465	910	615	440	325	175	90	

Result:		L1 [mm]							
Load F [kg]		150	200	250	400	600	800	1000	1200
x [mm]	80	135	115	95	65	45	35	25	20
	100	155	130	115	80	60	45	35	30
	125	175	150	130	95	70	55	45	35
	150	190	165	145	110	80	65	55	45
	175	200	175	160	120	90	70	60	50
	200	210	190	170	130	100	80	65	60



Result:		F [kg]							
L1 [mm]		50	75	100	125	150	200	250	300
→ Load in [kN]		0.49	0.74	0.98	1.23	1.47	1.96	2.45	2.94
x [mm]	80	1170	780	585	455	360	245	175	130
	100	1465	975	730	570	455	305	220	160
	125	1830	1220	915	715	570	385	275	200
	150	2200	1465	1100	860	680	460	330	240
	175	2565	1710	1280	1000	795	540	385	280
	200	2935	1955	1465	1145	910	615	440	325

Result:		L1 [mm]							
Load F [kg]		150	200	250	400	600	800	1000	1200
x [mm]	80	275	230	195	135	95	70	55	45
	100	310	265	230	165	120	90	70	60
	125	350	300	265	195	140	110	90	75
	150	380	330	295	220	165	130	110	90
	175	405	355	320	245	185	145	125	105
	200	425	380	340	265	200	165	135	120

NOTE: load capacity used for calculation $N_{rec} = 3.6 \text{ kN (axial)} / V_{rec} = 2.75 \text{ kN (shear)}$

[FASTENER SYSTEM](#)
[FASTENER OVERVIEW](#)
[FASTENER TECHNICAL DETAILS](#)
[APPLICATION OVERVIEW](#)
[HOW TO USE THIS DOCUMENT](#)
[DISCLAIMER](#)

FASTENING JUNCTION BOXES / SWITCHES WITH S-BT HL

S-BT-MR HL / S-BT-MF MT HL Threaded stud

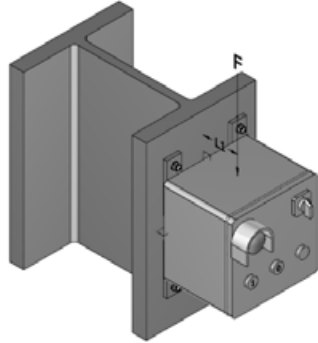

Application

- Fastening of junction boxes, switches on a vertical structure
- Element is fastened by S-BT HL

Boundary conditions

- These values are ONLY reflecting capacity of S-BT HL threaded stud. Structural analysis of support / structure is NOT in Hilti scope. See the detailed statements in disclaimer—2018/05/04
- Technical data are based on Product Data Sheet for S-BT HL (12/2022), always refer to latest Product Data Sheet for S-BT HL

Technical data — always refer to latest technical data binder for S-BT HL

Recommended load	S-BT-MR HL		S-BT-MF MT HL		S-BT-MF HL	
Drill hole type and base material thickness			Pilot hole, $t_{II} \geq 6 \text{ mm}$ Drill through hole, $5 \text{ mm} \leq t_{II} < 6 \text{ mm}$			
Base material	Steel S235	Steel S355	Steel S235	Steel S355	Steel S235	Steel S355
Tension, N_{rec} [kN]	3.6	4.3	4	4.8	4	4.8
Shear, V_{rec} [kN]	4.1	4.1	4	4	2.8	2.8
Moment, M_{rec} [Nm]	11.1	11.1	6.7	6.7	6.7	6.7

Design resistance	S-BT-MR HL		S-BT-MF MT HL		S-BT-MF HL	
Drill hole type and base material thickness			Pilot hole, $t_{II} \geq 6 \text{ mm}$ Drill through hole, $5 \text{ mm} \leq t_{II} < 6 \text{ mm}$			
Base material	Steel S235	Steel S355	Steel S235	Steel S355	Steel S235	Steel S355
Tension, N_{Rec} [kN]	5.1	6.1	5.7	6.8	5.7	6.8
Shear, V_{Rec} [kN]	5.7	5.7	5.6	5.6	3.9	3.9
Moment, M_{Rec} [Nm]	15.6	15.6	9.4	9.4	9.4	9.4

Conditions for recommended loads and design loads

- Use S-BT-MR HL and S-BT-MF (MT) HL (multipurpose fastening) only with the supplied Hilti serrated flange nuts M8, M10, W10 (⊗ or ⊚ as per according to General Information—Material specifications)
- Global factor of safety Ω resp. partial factor of safety γ_m (based on 5% fractile ultimate test value)

	Recommended Loads	Design loads
Static pull-out	2.80	2.00
Static shear	2.80	2.00
Bending	1.75	1.25

- Minimum edge distance = 6 mm [0.24"], minimum spacing $\geq 18 \text{ mm}$ [0.709"]
- Effect of base metal vibration and stress (e.g. areas with tensile stress) considered.
- Redundancy (multiple fastening) must be provided.
- If eccentric loading exists (e.g. use of an angle clip), moments caused by off-center loading must be considered.

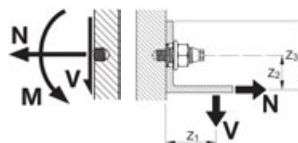

Recommended interaction formula for combined loading — steel and aluminum base material

$$\mathbf{V-N} \text{ (shear and tension)} \quad \frac{V}{V_{rec}} + \frac{N}{N_{rec}} \leq 1.0 \text{ with } \frac{V}{V_{rec}} \leq 1.0 \text{ and } \frac{N}{N_{rec}} \leq 1.0$$

$$\mathbf{V-M} \text{ (shear and bending)} \quad \frac{V}{V_{rec}} + \frac{M}{M_{rec}} \leq 1.0 \text{ with } \frac{V}{V_{rec}} \leq 1.0 \text{ and } \frac{M}{M_{rec}} \leq 1.0$$

$$\mathbf{N-M} \text{ (tension and bending)} \quad \frac{N}{N_{rec}} + \frac{M}{M_{rec}} \leq 1.0$$

$$\mathbf{V-N-M} \text{ (shear, tension and bending)} \quad \frac{V}{V_{rec}} + \frac{N}{N_{rec}} + \frac{M}{M_{rec}} \leq 1.0$$

Cyclic loading

S-BT HL threaded studs are only to be used for fastenings subject to static or quasi-static loading. Inquire at Hilti for test data if cyclic loading has to be considered in the design.

S-BT HL CATALOG PAGES

Description	Base Material	Environment	Item Number
Threaded stud S-BT-MF M8/7 AN 6 HL	Steel	Mildly corrosive	2345768
Threaded stud S-BT-MF M8/15 AN 6 HL	Steel	Mildly corrosive	2345769
Threaded stud S-BT-MF M10/15 AN 6 HL	Steel	Mildly corrosive	2346060
Threaded stud S-BT-MF W10/15 AN 6 HL	Steel	Mildly corrosive	2346061
Threaded stud S-BT-MF MT M10/15 AN 6 HL	Steel	Mildly corrosive	2350549
Threaded stud S-BT-MF MT W10/15 AN 6 HL	Steel	Mildly corrosive	2350880
Threaded stud S-BT-MR M8/7 SN 6 HL	Steel	Highly corrosive	2346062
Threaded stud S-BT-MR M8/15 SN 6 HL	Steel	Highly corrosive	2346063
Threaded stud S-BT-MR M10/15 SN 6 HL	Steel	Highly corrosive	2346064
Threaded stud S-BT-MR W10/15 SN 6 HL	Steel	Highly corrosive	2346065



Description	Item Number
Stepped drill bit TS-BT 5.3-65 S	2346083
Stud holder S-SH BT M8	2361441
Stud holder S-SH BT M10/W10	2361442
Nut setter S-NS 13 C 95/3 1/4"	2149244
Nut setter S-NS 15 C 95/3 1/4"	2149245
Nut setter S-NS 9/16" C 95/3 3/4"	2149246
Depth gauge S-DG BT M8/7 Short 6	2279735
Depth gauge S-DG BT M8/15 Long 6	2148575
Depth gauge S-DG BT M10-W10/15 Long 6	2143261
Check gauge S-CG BT /7 Short 6	2143262
Check gauge S-CG BT /15 long 6	2143263
Inspection card S-IC BT	2383883
Calibration card S-CC BT 6	2143270
Torque tool S-BT 1/4" — 16 Nm / 11.8 lbf-ft	2346085
SBT 4-A22	Refer to Hilti Online
SBT 6-22	Refer to Hilti Online





6PCH4134072191
B16126011063
FOTO: M. GIOVANNI / FOTOFESTIVAL / CONTRASTO

AEG
C350
B16



X-ST-GR THREADED STUD

Metric



X-ST-GR TECHNICAL DATA USED FOR THE FOLLOWING CALCULATIONS

X-ST-GR technical data

- **Drill hole type / base material:** no predrilling, $t_{II} \geq 6 \text{ mm}$ (0.24")
- **Base material:** Steel S235 / A36 (higher steel strength is possible, see application limit)
- **Recommended interaction for combined load:** $N_{rec} = 1.8 \text{ kN}$ (axial) / $V_{rec} = 1.8 \text{ kN}$ (shear)

V-N (shear and tension)

$$\frac{V}{V_{rec}} + \frac{N}{N_{rec}} \leq 1.2 \quad \text{with} \quad \frac{V}{V_{rec}} \leq 1.0 \quad \text{and} \quad \frac{N}{N_{rec}} \leq 1.0$$

Application limit

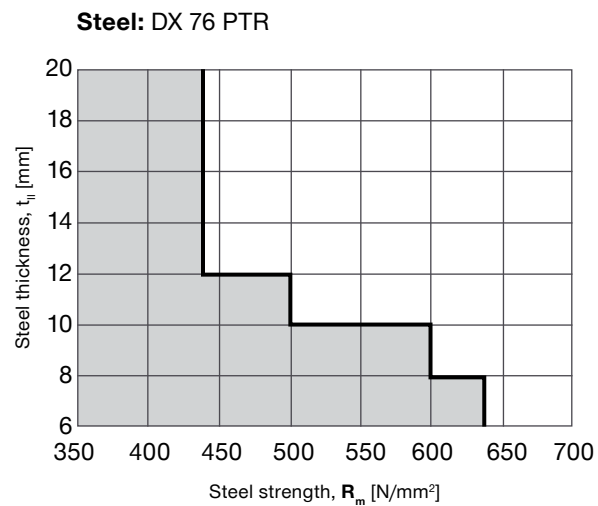
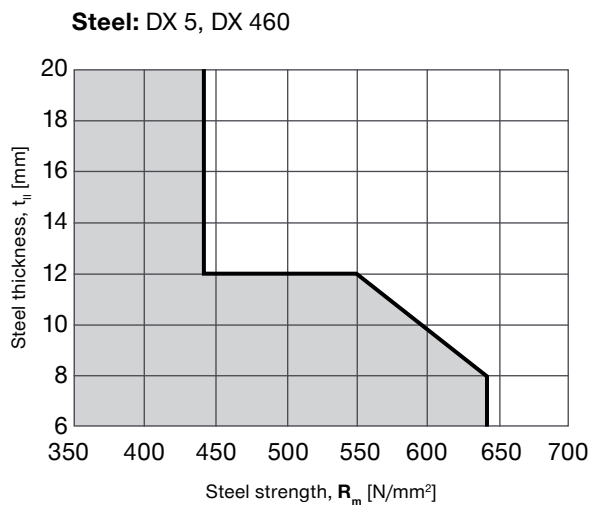

For further technical data refer to the latest technical information (DFTM / binder)

FASTENING CANTILEVER SUPPORT WITH X-ST-GR

Two / Four X-ST-GR Threaded studs

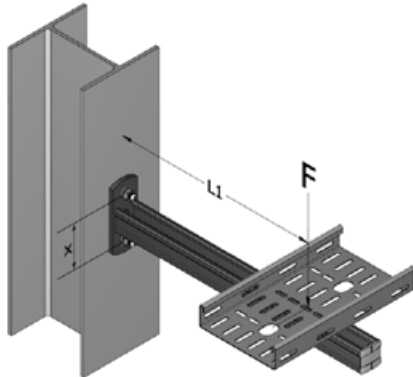

Application

- Fastening of cable trays, pipes on a horizontal cantilever support, fastened on a vertical structure
- Support is fastened by two / four X-ST-GR on both support and brace baseplate with distance x
- L1 is the distance of the load center to the vertical structure surface
- Load F is the acceptable total load (all dead load including)

Boundary conditions

- These values are ONLY reflecting capacity of X-ST-GR threaded stud. Structural analysis of support / structure is NOT in Hilti scope. See the detailed statements in disclaimer—2018/05/04
- Shear load fully carried by one / two top X-ST-GR (worst-case)
- Load F acting at the distance of L1 from structure surface

Technical assessment – maximum of L1 and F (depending on load F or lever arm length L1 and X-ST-GR distance x)

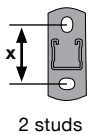

2 studs

Result: L1 [mm]	F [kg]							
	50	75	100	125	150	200	250	300
→ Load in [kN]	0.49	0.74	0.98	1.23	1.47	1.96	2.45	2.94
x [mm]	80	270	150	95	60	35		
	100	340	190	120	75	45		
	125	425	240	150	95	55		
	150	510	290	180	110	70		
	175	595	335	210	130	80		
	200	680	385	240	150	90		

Result: Load F [kg]	L1 [mm]							
	150	200	250	400	600	800	1000	1200
x [mm]	80	75	60	50	35	20	15	10
	100	85	70	60	40	30	20	15
	125	100	80	70	50	35	25	20
	150	110	90	80	60	40	30	25
	175	115	100	90	65	45	35	30
	200	125	110	95	70	55	40	35

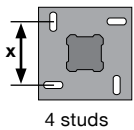

4 studs

Result: L1 [mm]	F [kg]							
	50	75	100	125	150	200	250	300
→ Load in [kN]	0.49	0.74	0.98	1.23	1.47	1.96	2.45	2.94
x [mm]	80	585	385	270	200	150	95	60
	100	730	485	340	250	190	120	75
	125	915	605	425	315	240	150	95
	150	1100	730	510	375	290	180	110
	175	1280	850	595	440	335	210	130
	200	1465	970	680	500	385	240	150

Result: Load F [kg]	L1 [mm]							
	150	200	250	400	600	800	1000	1200
x [mm]	80	150	125	105	70	45	35	25
	100	175	145	125	85	60	45	35
	125	200	165	145	100	75	55	45
	150	220	185	165	120	85	65	55
	175	235	205	180	130	95	75	60
	200	250	220	195	145	110	85	70

NOTE: load capacity used for calculation $N_{rec} = 1.8 \text{ kN}$ (axial) / $V_{rec} = 1.8 \text{ kN}$ (shear)

[FASTENER SYSTEM](#)
[FASTENER OVERVIEW](#)
[FASTENER TECHNICAL DETAILS](#)
[APPLICATION OVERVIEW](#)
[HOW TO USE THIS DOCUMENT](#)
[DISCLAIMER](#)

FASTENING BRACED CANTILEVER SUPPORT WITH X-ST-GR

Two / Four X-ST-GR Threaded studs

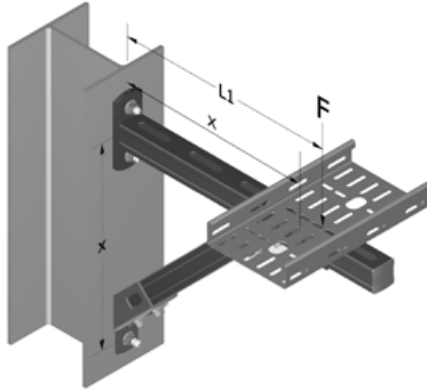

Application

- Fastening of cable trays, pipes on a horizontal, braced cantilever support, fastened on a vertical structure
- Support is fastened by three / six X-ST-GR on both support and brace baseplate with distance x
- L1 is the distance of the load center to the vertical structure surface, the angle of the brace is 45°
- Load F is the acceptable total load (all dead load including)

Boundary conditions

- These values are ONLY reflecting capacity of X-ST-GR threaded stud. Structural analysis of support / structure is NOT in Hilti scope. See the detailed statements in disclaimer—2018/05/04
- Shear load fully carried by one / two top X-ST-GR (worst-case)
- Load F acting at the distance of L1 from structure surface

Technical assessment — maximum of F (depending on load F or lever arm length L1 and baseplate distance x)

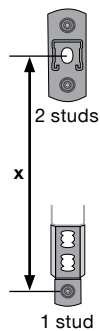

Result:	F [kg]							
L1 [mm]	50	75	100	125	150	200	250	300
→ Load in [kN]	0.49	0.74	0.98	1.23	1.47	1.96	2.45	2.94
x [mm]	100	360	240	180	145	120		
	150	540	365	275	220	180		
	200	720	485	365	290	240		
	350	1260	855	640	510	425		
	500	1800	1220	915	730	610		
	800	2880	1955	1465	1170	975		

Result:	L1 [mm]							
Load F [kg]	150	200	250	400	600	800	1000	1200
x [mm]	100	120	90	70	45	30		
	150	180	135	110	65	45		
	200		180	145	90	60		
	350				160	105		
	500					150		
	800							

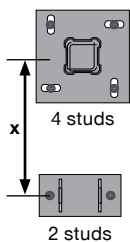

Result:	F [kg]							
L1 [mm]	50	75	100	125	150	200	250	300
→ Load in [kN]	0.49	0.74	0.98	1.23	1.47	1.96	2.45	2.94
x [mm]	100	650	455	360	290	240	180	145
	150	980	685	540	440	365	275	220
	200	1305	915	720	585	485	365	290
	350	2285	1600	1260	1025	855	640	510
	500	3265	2290	1800	1465	1220	915	730
	800	5230	3660	2880	2345	1955	1465	1170

Result:	L1 [mm]							
Load F [kg]	150	200	250	400	600	800	1000	1200
x [mm]	100	240	180	145	90	60		
	150	365	275	220	135	90	65	55
	200		365	290	180	120	90	70
	350				320	210	160	125
	500					305	225	180
	800						365	290

NOTE: load capacity used for calculation $N_{rec} = 1.8 \text{ kN (axial)} / V_{rec} = 1.8 \text{ kN (shear)}$

[FASTENER SYSTEM](#)
[FASTENER OVERVIEW](#)
[FASTENER TECHNICAL DETAILS](#)
[APPLICATION OVERVIEW](#)
[HOW TO USE THIS DOCUMENT](#)
[DISCLAIMER](#)

FASTENING STRUT TO STEEL WITH X-ST-GR

Two X-ST-GR Threaded studs

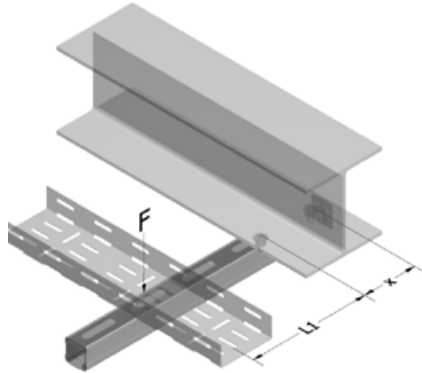

Application

- Fastening of cable trays, pipes on a horizontal cantilever support, fastened on a horizontal structure
- Support is fastened by two X-ST-GR (horizontal distance x)
- L1 is the distance of the load center to the vertical structure surface
- Load F is the acceptable total load (all dead load including)

Boundary conditions

- These values are ONLY reflecting capacity of X-ST-GR threaded stud. Structural analysis of support / structure is NOT in Hilti scope. See the detailed statements in disclaimer—2018/05/04
- Load F acting at the distance of L1 from structure surface

Technical assessment – maximum of L1 and F (depending on load F or lever arm length L1 and X-ST-GR distance x)

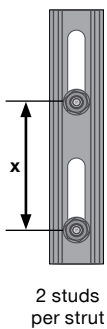

Result: L1 [mm]	F [kg]							
	50	75	100	125	150	200	250	300
→ Load in [kN]	0.49	0.74	0.98	1.23	1.47	1.96	2.45	2.94
x [mm]	80	210	115	65	35	15		
	100	265	140	80	45	20		
	125	330	180	100	55	25		
	150	400	215	125	70	30		
	175	465	250	145	80	35		
	200	530	285	165	90	40		

Result: Load F [kg]	L1 [mm]							
	150	200	250	400	600	800	1000	1200
x [mm]	80	60	50	40	30	20	15	10
	100	70	60	50	35	25	20	15
	125	80	70	60	40	30	20	15
	150	90	75	65	50	35	25	20
	175	95	85	75	55	40	30	25
	200	100	90	80	60	45	35	30

NOTE: load capacity used for calculation $N_{rec} = 1.8 \text{ kN (axial)} / V_{rec} = 1.8 \text{ kN (shear)}$

[FASTENER SYSTEM](#)
[FASTENER OVERVIEW](#)
[FASTENER TECHNICAL DETAILS](#)
[APPLICATION OVERVIEW](#)
[HOW TO USE THIS DOCUMENT](#)
[DISCLAIMER](#)

FASTENING STRUT TO STEEL WITH X-ST-GR

Two / Four X-ST-GR Threaded studs

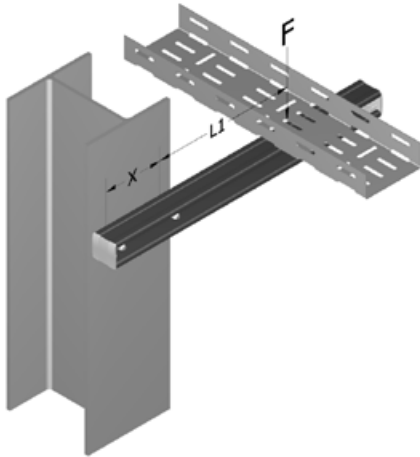

Application

- Fastening of cable trays, pipes on a horizontal cantilever support, fastened on a vertical structure
- Support is fastened by two X-ST-GR (horizontal distance x)
- L1 is the distance of the load center to the center of the fasteners
- Load F is the acceptable total load (all dead load including)

Boundary conditions

- These values are ONLY reflecting capacity of X-ST-GR threaded stud. Structural analysis of support / structure is NOT in Hilti scope. See the detailed statements in disclaimer—2018/05/04
- Shear load fully carried by one X-ST-GR (worst-case)
- Load F acting at the distance of L1 from structure surface

Technical assessment – maximum of L1 and F (depending on load F or lever arm length L1 and X-ST-GR distance x)

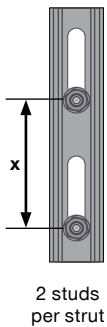

Result: L1 [mm]	F [kg]							
	50	75	100	125	150	200	250	300
→ Load in [kN]	0.49	0.74	0.98	1.23	1.47	1.96	2.45	2.94
x [mm]	80	210	115	65	35	15		
	100	265	140	80	45	20		
	125	330	180	100	55	25		
	150	400	215	125	70	30		
	175	465	250	145	80	35		
	200	530	285	165	90	40		

Result: Load F [kg]	L1 [mm]							
	150	200	250	400	600	800	1000	1200
x [mm]	80	60	50	40	30	20	15	10
	100	70	60	50	35	25	20	15
	125	80	70	60	40	30	20	15
	150	90	75	65	50	35	25	20
	175	95	85	75	55	40	30	25
	200	100	90	80	60	45	35	30

NOTE: load capacity used for calculation $N_{rec} = 1.8 \text{ kN (axial)} / V_{rec} = 1.8 \text{ kN (shear)}$

FASTENER SYSTEM	FASTENER OVERVIEW	FASTENER TECHNICAL DETAILS	APPLICATION OVERVIEW
HOW TO USE THIS DOCUMENT	DISCLAIMER		

FASTENING T-POST (CEILING) SUPPORT WITH X-ST-GR

Two / Four X-ST-GR Threaded studs

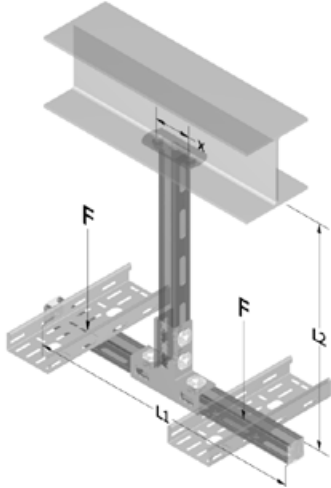

Application

- Fastening of cable trays, pipes on a T-Post support, which is fastened on a horizontal structure
- Support is fastened by two / four X-ST-GR (horizontal distance x)
- $L1$ is the total width of the T-Post, $L2$ is fix set to 1000 mm
- Load F is the acceptable total load (all dead load including)

Boundary conditions

- These values are ONLY reflecting capacity of X-ST-GR threaded stud. Structural analysis of support / structure is NOT in Hilti scope. See the detailed statements in disclaimer—2018/05/04
- 2 Load cases: load asymmetric acting in the center of one arm only, 30% acting as horizontal load

Technical assessment – maximum of $L1$ and F (depending on load F or lever arm length $L1$ and X-ST-GR distance x)

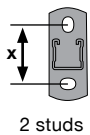

2 studs

Result: L1 [mm]	F [kg]							
	50	75	100	125	150	200	250	300
→ Load in [kN]	0.49	0.74	0.98	1.23	1.47	1.96	2.45	2.94
x [mm]	80							
	100	1265						
	125	1580						
	150	1900						
	175	2215	1360					
	200	2535	1555					

Result: Load F [kg]	L1 [mm]							
	150	200	250	400	600	800	1000	1200
x [mm]	80	40	40	40	40	40	40	40
	100	50	50	50	50	50	50	50
	125	60	60	60	60	60	60	60
	150	70	70	70	70	70	70	70
	175	80	80	80	80	80	80	80
	200	90	90	90	90	90	90	90

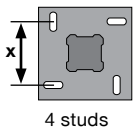

4 studs

Result: L1 [mm]	F [kg]							
	50	75	100	125	150	200	250	300
→ Load in [kN]	0.49	0.74	0.98	1.23	1.47	1.96	2.45	2.94
x [mm]	80	2185	1405					
	100	2735	1755	1265				
	125	3415	2195	1580				
	150	4100	2635	1900	1460			
	175	4785	3075	2215	1705	1360		
	200	5470	3510	2535	1945	1555		

Result: Load F [kg]	L1 [mm]							
	150	200	250	400	600	800	1000	1200
x [mm]	80	75	75	75	75	75	75	75
	100	90	90	90	90	90	90	90
	125	105	105	105	105	105	105	105
	150	120	120	120	120	120	120	120
	175	135	135	135	135	135	135	135
	200	145	145	145	145	145	145	145

NOTE: load capacity used for calculation $N_{rec} = 1.8 \text{ kN}$ (axial) / $V_{rec} = 1.8 \text{ kN}$ (shear)

[FASTENER SYSTEM](#)
[FASTENER OVERVIEW](#)
[FASTENER TECHNICAL DETAILS](#)
[APPLICATION OVERVIEW](#)
[HOW TO USE THIS DOCUMENT](#)
[DISCLAIMER](#)

FASTENING T-POST (FLOOR) SUPPORT WITH X-ST-GR

Two / Four X-ST-GR Threaded studs

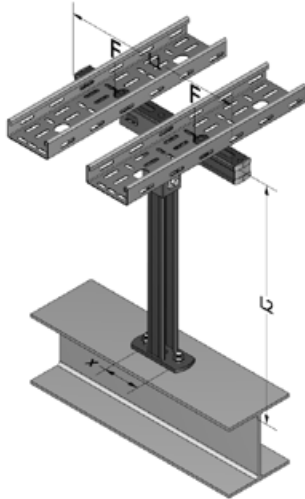

Application

- Fastening of cable trays, pipes on a T-Post support, which is fastened on a horizontal structure
- Support is fastened by two / four X-ST-GR (horizontal distance x)
- L1 is the total width of the T-Post, L2 is fix set to 1000 mm
- Load F is the acceptable total load (all dead load including)

Boundary conditions

- These values are ONLY reflecting capacity of X-ST-GR threaded stud. Structural analysis of support / structure is NOT in Hilti scope. See the detailed statements in disclaimer—2018/05/04
- 2 Load cases: load asymmetric acting in the center of one arm only, 30% acting as horizontal load

Technical assessment – maximum of L1 and F (depending on load F or lever arm length L1 and X-ST-GR distance x)

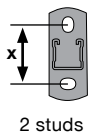

2 studs

Result: L1 [mm]	F [kg]								
	50	75	100	125	150	200	250	300	
→ Load in [kN]	0.49	0.74	0.98	1.23	1.47	1.96	2.45	2.94	
x [mm]	80								
	100	1665							
	125	2080	1470						
	150	2500	1765						
	175	2915	2060	1630					
	200	3335	2355	1865					

Result: Load F [kg]	L1 [mm]							
	150	200	250	400	600	800	1000	1200
x [mm]	80	45	45	45	45	45	45	45
	100	60	60	60	60	60	60	60
	125	75	75	75	75	75	75	75
	150	90	90	90	90	90	90	90
	175	105	105	105	105	105	105	105
	200	120	120	120	120	120	120	120

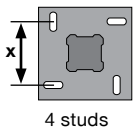

4 studs

Result: L1 [mm]	F [kg]								
	50	75	100	125	150	200	250	300	
→ Load in [kN]	0.49	0.74	0.98	1.23	1.47	1.96	2.45	2.94	
x [mm]	80								
	100	3135							
	125	3915	2695						
	150	4700	3235						
	175	5485	3775	2915					
	200	6270	4310	3335					

Result: Load F [kg]	L1 [mm]							
	150	200	250	400	600	800	1000	1200
x [mm]	80	95	95	95	95	95	95	95
	100	120	120	120	120	120	120	120
	125	150	150	150	150	150	150	150
	150	180	180	180	180	180	180	180
	175	210	210	210	210	210	210	210
	200	240	240	240	240	240	240	240

NOTE: load capacity used for calculation $N_{rec} = 1.8 \text{ kN}$ (axial) / $V_{rec} = 1.8 \text{ kN}$ (shear)

[FASTENER SYSTEM](#)
[FASTENER OVERVIEW](#)
[FASTENER TECHNICAL DETAILS](#)
[APPLICATION OVERVIEW](#)
[HOW TO USE THIS DOCUMENT](#)
[DISCLAIMER](#)

FASTENING U-FRAME (CEILING) / TRAPEZE SUPPORT WITH X-ST-GR

Two / Four X-ST-GR Threaded studs

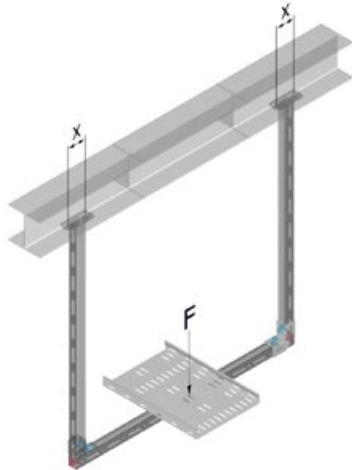

Application

- Fastening of cable trays, pipes on a U-Frame support, which is fastened on a horizontal structure
- Support is fastened by four X-ST-GR (2 fasteners per baseplate)
- Load F is the acceptable total load (all dead load including, acting in the center of the U-Frame)

Boundary conditions

- These values are ONLY reflecting capacity of X-ST-GR threaded stud. Structural analysis of support / structure is NOT in Hilti scope. See the detailed statements in disclaimer—2018/05/04
- Load acting in the center (U-Frame)

Technical assessment — maximum of F

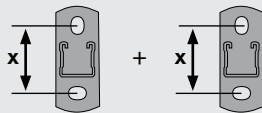
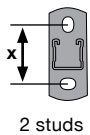

$$F = N_{rec} \cdot \text{\#fasteners per post}$$

$$F = 1.8 \text{ kN} \cdot 4$$

$$F = 7.2 \text{ kN} / F = 730 \text{ kg}$$

NOTE: load capacity used for calculation $N_{rec} = 1.8 \text{ kN (axial)} / V_{rec} = 1.8 \text{ kN (shear)}$

FASTENER SYSTEM

FASTENER OVERVIEW

FASTENER TECHNICAL DETAILS

APPLICATION OVERVIEW

HOW TO USE THIS DOCUMENT

DISCLAIMER

FASTENING L-POST SUPPORT WITH X-ST-GR

Two / Four X-ST-GR Threaded studs

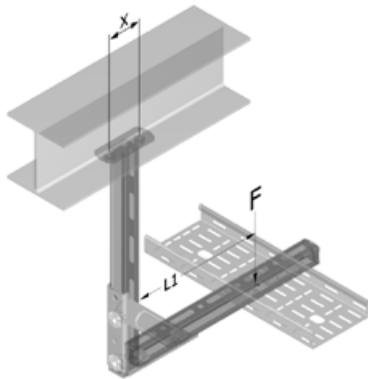

Application

- Fastening of cable trays, pipes on a L-Post support, which is fastened on a horizontal structure
- Support is fastened by two / four X-ST-GR (horizontal distance x)
- L1 is the distance of the load center to the vertical structure surface
- Load F is the acceptable total load (all dead load including)

Boundary conditions

- These values are ONLY reflecting capacity of X-ST-GR threaded stud. Structural analysis of support / structure is NOT in Hilti scope. See the detailed statements in disclaimer—2018/05/04
- Load F acting at the distance of L1 from structure surface

Technical assessment – maximum of L1 and F (depending on load F or lever arm length L1 and X-ST-GR distance x)

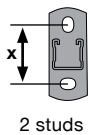

2 studs

Result: L1 [mm]	F [kg]								
	50	75	100	125	150	200	250	300	
→ Load in [kN]	0.49	0.74	0.98	1.23	1.47	1.96	2.45	2.94	
x [mm]	80	250	155	105	75	55	30	15	5
	100	315	190	130	95	70	40	20	10
	125	395	240	165	120	90	50	25	10
	150	475	290	200	145	105	60	35	15
	175	550	340	230	165	125	70	40	15
	200	630	385	265	190	140	80	45	20

Result: Load F [kg]	L1 [mm]							
	150	200	250	400	600	800	1000	1200
x [mm]	80	75	60	50	30	20	15	10
	100	90	70	60	40	25	20	15
	125	105	85	70	45	30	25	20
	150	120	100	80	55	40	30	25
	175	135	110	95	65	45	35	25
	200	145	120	100	70	50	40	30

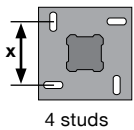

4 studs

Result: L1 [mm]	F [kg]								
	50	75	100	125	150	200	250	300	
→ Load in [kN]	0.49	0.74	0.98	1.23	1.47	1.96	2.45	2.94	
x [mm]	80	545	350	250	190	155	105	75	55
	100	680	435	315	240	190	130	95	70
	125	850	545	395	300	240	165	120	90
	150	1025	655	475	365	290	200	145	105
	175	1195	765	550	425	340	230	165	125
	200	1365	875	630	485	385	265	190	140

Result: Load F [kg]	L1 [mm]								
	150	200	250	400	600	800	1000	1200	
x [mm]	80	150	120	100	65	45	30	25	20
	100	180	145	120	80	55	40	30	25
	125	215	170	145	95	65	50	40	35
	150	240	200	165	115	80	60	50	40
	175	270	220	190	130	90	70	55	45
	200	290	240	205	145	100	80	65	55

NOTE: load capacity used for calculation $N_{rec} = 1.8 \text{ kN (axial)} / V_{rec} = 1.8 \text{ kN (shear)}$

[FASTENER SYSTEM](#)
[FASTENER OVERVIEW](#)
[FASTENER TECHNICAL DETAILS](#)
[APPLICATION OVERVIEW](#)
[HOW TO USE THIS DOCUMENT](#)
[DISCLAIMER](#)

FASTENING EQUIPMENT SUPPORT WITH X-ST-GR

Two / Four X-ST-GR Threaded studs

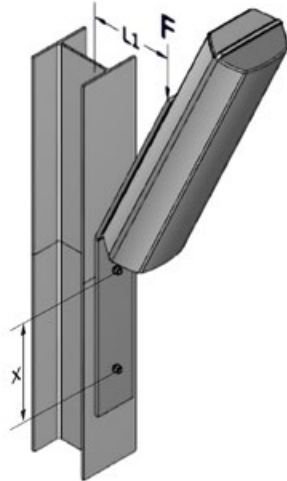

Application

- Fastening of lamps, signals, sensors on inclined cantilever support, fastened on a vertical structure
- Support is fastened by two / four X-ST-GR (vertical distance x)
- L1 is the distance of the load center (~middle of the load) to the vertical structure surface
- Load F is the acceptable total load (all dead load including)

Boundary conditions

- These values are ONLY reflecting capacity of X-ST-GR threaded stud. Structural analysis of support / structure is NOT in Hilti scope. See the detailed statements in disclaimer—2018/05/04
- Shear load fully carried by one / two top X-ST-GR (worst-case)
- Load F acting at the distance of L1 from structure surface

Technical assessment – maximum of L1 and F (depending on load F or lever arm length L1 and X-ST-GR distance x)

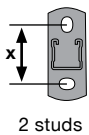

2 studs

Result: L1 [mm]	F [kg]							
	50	75	100	125	150	200	250	300
→ Load in [kN]	0.49	0.74	0.98	1.23	1.47	1.96	2.45	2.94
x [mm]	80	270	150	95	60	35		
	100	340	190	120	75	45		
	125	425	240	150	95	55		
	150	510	290	180	110	70		
	175	595	335	210	130	80		
	200	680	385	240	150	90		

Result: Load F [kg]	L1 [mm]							
	150	200	250	400	600	800	1000	1200
x [mm]	80	75	60	50	35	20	15	10
	100	85	70	60	40	30	20	15
	125	100	80	70	50	35	25	20
	150	110	90	80	60	40	30	25
	175	115	100	90	65	45	35	30
	200	125	110	95	70	55	40	35

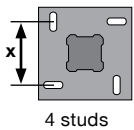

4 studs

Result: L1 [mm]	F [kg]							
	50	75	100	125	150	200	250	300
→ Load in [kN]	0.49	0.74	0.98	1.23	1.47	1.96	2.45	2.94
x [mm]	80	540	305	190	120	70		
	100	680	385	240	150	90		
	125	850	480	300	190	115		
	150	1020	580	360	225	140		
	175	1190	675	420	265	160		
	200	1360	770	480	300	185		

Result: Load F [kg]	L1 [mm]							
	150	200	250	400	600	800	1000	1200
x [mm]	80	150	125	105	70	45	35	25
	100	175	145	125	85	60	45	35
	125	200	165	145	100	75	55	45
	150	220	185	165	120	85	65	55
	175	235	205	180	130	95	75	60
	200	250	220	195	145	110	85	70

NOTE: load capacity used for calculation $N_{rec} = 1.8 \text{ kN (axial)} / V_{rec} = 1.8 \text{ kN (shear)}$

[FASTENER SYSTEM](#)
[FASTENER OVERVIEW](#)
[FASTENER TECHNICAL DETAILS](#)
[APPLICATION OVERVIEW](#)
[HOW TO USE THIS DOCUMENT](#)
[DISCLAIMER](#)

FASTENING JUNCTION BOXES / SWITCHES WITH X-ST-GR

X-ST-GR Threaded stud

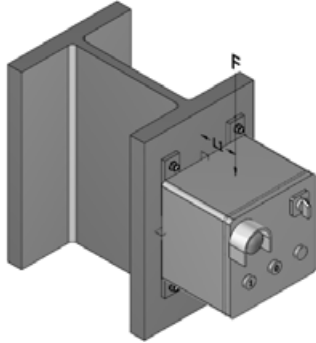

Application

- Fastening of junction boxes, switches on a vertical structure
- Element is fastened by X-ST-GR

Boundary conditions

- These values are ONLY reflecting capacity of X-ST-GR threaded stud. Structural analysis of support / structure is NOT in Hilti scope. See the detailed statements in disclaimer—2018/05/04
- Technical data are based on technical data binder for X-ST-GR (06 / 2018), always refer to latest technical data binder for X-ST-GR

Technical data — always refer to latest technical data binder for X-ST

Recommended load	X-ST
Base material thickness	$t_{II} \geq 6 \text{ mm (0.24")}$
Base material	Steel $R_m \geq 350 \text{ MPa}$
Tension, N_{rec} [kN]	1.8
Shear, V_{rec} [kN]	1.8
Moment, M_{rec} [Nm]	5.5

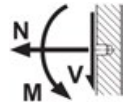

Application limit

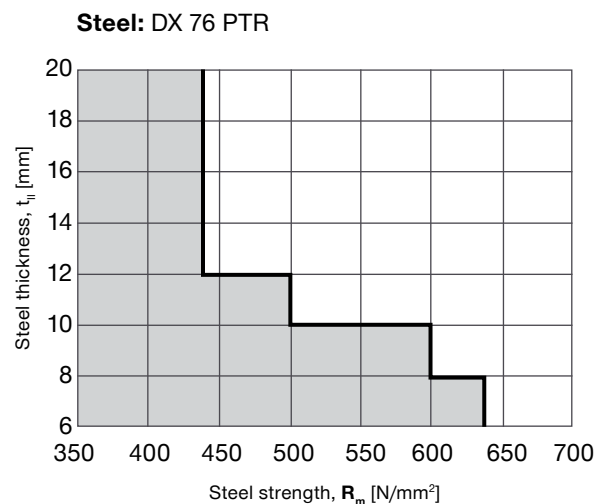
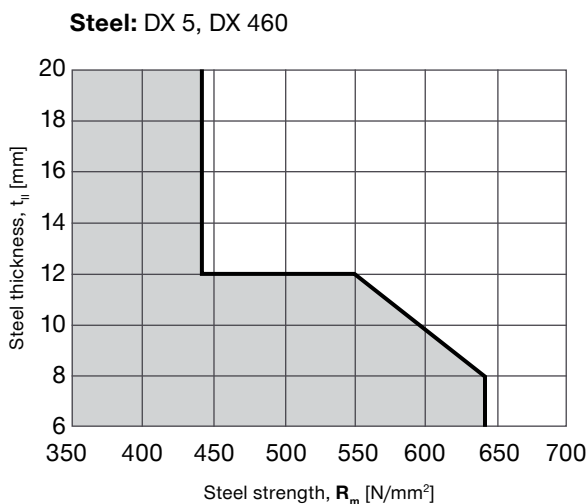

X-ST-GR CATALOG PAGES

Description	Base Material	Environment	Item Number
X-ST-GR M8/10 P8	Steel	Mildly corrosive	2122460



Description	Item Number
DX 76 PTR	Local item
DX 5 GR	Local item
X-5 460 F8 N15 Fastener guide	304530
X-5 460 P8 Piston	373297
Cartridge 6.8/11 M10 STD red	416474
Cartridge 6.8/11 M10 STD black	416475
X-76-F-8-GR-PTR Fastener guide	388852
Cartridge 6.8/18 M10 .27 cal C-T yellow	416483
Cartridge 6.8/18 M10 .27 cal C-T red	416484







X-BT-MR THREADED STUD (NEW GENERATION)

Imperial

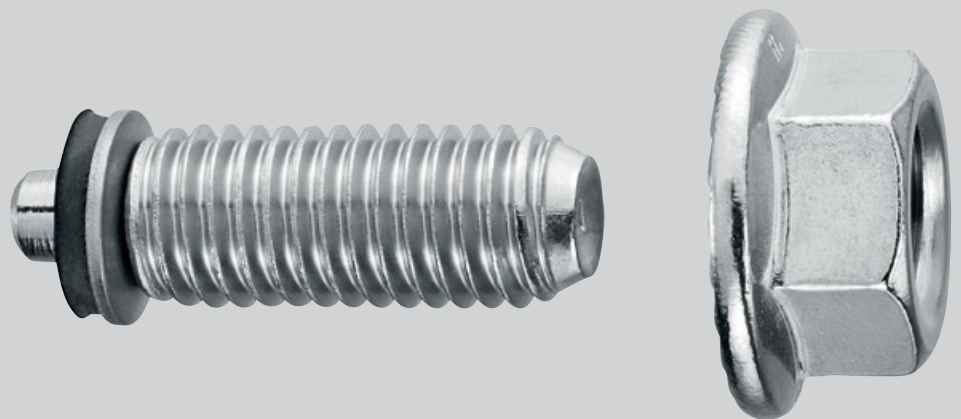

X-BT-MR (NEW GENERATION) TECHNICAL DATA

X-BT-MR technical data

- **Drill hole type / base material:** Pilot hole, $t_{II} \geq 8$ mm (0.31")
- **Base material:** Steel S235 / A36 (higher steel strength is possible, increases the rec. load)
- **Recommended interaction for combined load:** $N_{rec} = 810$ lb (axial) / $V_{rec} = 970$ lb (shear)

V-N (shear and tension)

$$\frac{V}{V_{rec}} + \frac{N}{N_{rec}} \leq 1.2 \quad \text{with} \quad \frac{V}{V_{rec}} \leq 1.0 \quad \text{and} \quad \frac{N}{N_{rec}} \leq 1.0$$

For further technical data refer to DFTM / New Generation Hilti X-BT-GR, X-BT-MR and X-BT-ER Threaded Fastener Specification [June 2018].

FASTENING CANTILEVER SUPPORT WITH X-BT-MR*

Two / Four X-BT-MR Threaded studs

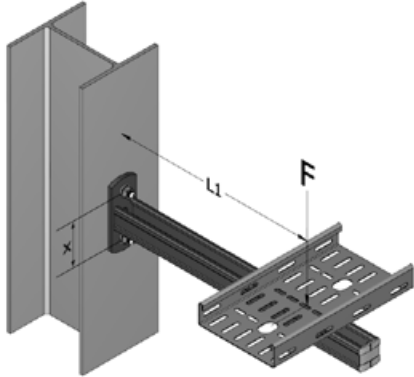

Application

- Fastening of cable trays, pipes, on a horizontal cantilever support, fastened on a vertical structure
- Support is fastened by two / four X-BT-MR on both support and brace baseplate with distance x
- L1 is the distance of the load center to the vertical structure surface
- Load F is the acceptable total load (all dead load including)

Boundary conditions

- These values are ONLY reflecting capacity of X-BT-MR threaded stud. Structural analysis of support / structure is NOT in Hilti scope. See the detailed statements in disclaimer—2018/05/04
- Shear load fully carried by one / two top X-BT-MR (worst-case)
- Load F acting at the distance of L1 from structure surface

Technical assessment – maximum of F (depending on load F or lever arm length L1 and baseplate distance x)

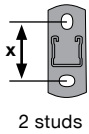

Result: L1 [inch]	F [lbs]								
	100	150	200	300	400	500	600	700	
x [inch]	3.0	21.75	13.75	9.75	5.50	3.50	2.25	1.50	1.00
	4.0	29.00	18.25	12.75	7.50	4.75	3.00	2.00	1.25
	5.0	36.25	22.75	16.00	9.25	6.00	4.00	2.50	1.50
	6.0	43.50	27.25	19.25	11.25	7.00	4.75	3.00	2.00
	7.0	50.75	32.00	22.50	13.00	8.25	5.50	3.50	2.25
	8.0	58.00	36.50	25.75	15.00	9.50	6.25	4.00	2.50

Result: Load F [lbs]	L1 [inch]								
	6.0	12.0	18.0	24.0	30.0	36.0	42.0	48.0	
x [inch]	3.0	285	167	118	91	75	63	54	48
	4.0	346	211	151	118	97	82	71	63
	5.0	397	250	182	143	118	101	88	77
	6.0	440	285	211	167	138	118	103	91
	7.0	477	317	237	190	158	135	118	105
	8.0	510	346	262	211	176	151	133	118

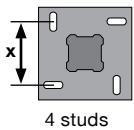

Result: L1 [inch]	F [lbs]								
	100	150	200	300	400	500	600	700	
x [inch]	3.0	46.00	29.75	21.75	13.50	9.50	7.00	5.50	4.25
	4.0	61.25	39.75	29.00	18.00	12.75	9.50	7.25	5.75
	5.0	76.50	49.75	36.25	22.75	16.00	12.00	9.25	7.25
	6.0	92.00	59.50	43.50	27.25	19.25	14.25	11.00	8.75
	7.0	107.25	69.50	50.75	31.75	22.25	16.75	13.00	10.25
	8.0	122.75	79.50	58.00	36.25	25.50	19.00	14.75	11.75

Result: Load F [lbs]	L1 [inch]								
	6.0	12.0	18.0	24.0	30.0	36.0	42.0	48.0	
x [inch]	3.0	570	334	237	183	149	126	109	96
	4.0	692	422	303	237	194	164	143	126
	5.0	794	500	365	287	237	201	175	155
	6.0	881	570	422	334	277	237	206	183
	7.0	955	634	475	379	316	271	237	210
	8.0	1,019	692	524	422	353	303	266	237

NOTE: load capacity used for calculation $N_{rec} = 810 \text{ lb (axial)} / V_{rec} = 970 \text{ lb (shear)}$

*X-BT-MR is the new generation X-BT

FASTENER SYSTEM	FASTENER OVERVIEW	FASTENER TECHNICAL DETAILS	APPLICATION OVERVIEW
HOW TO USE THIS DOCUMENT	DISCLAIMER		

FASTENING BRACED CANTILEVER SUPPORT WITH X-BT-MR*

Two / Four X-BT-MR Threaded studs

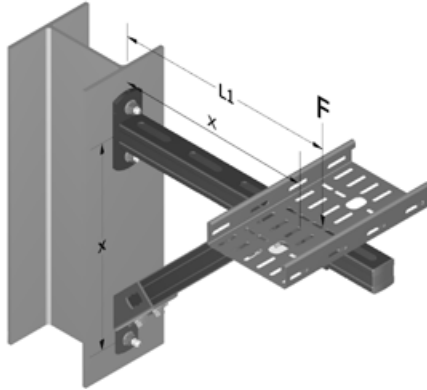

Application

- Fastening of cable trays, pipes on a horizontal, braced cantilever support, fastened on a vertical structure
- Support is fastened by three / six X-BT-MR on both support and brace baseplate with distance x
- L1 is the distance of the load center to the vertical structure surface, the angle of the brace is 45°
- Load F is the acceptable total load (all dead load including)

Boundary conditions

- These values are ONLY reflecting capacity of X-BT-MR threaded stud. Structural analysis of support / structure is NOT in Hilti scope. See the detailed statements in disclaimer—2018/05/04
- Shear load fully carried by one / two top X-BT-MR (worst-case)
- Load F acting at the distance of L1 from structure surface

Technical assessment – maximum of F (depending on load F or lever arm length L1 and baseplate distance x)

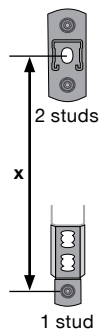

Result: L1 [inch]	F [lbs]							
	100	150	200	300	400	500	600	700
x 4.0	18.50	14.50	10.50	8.50	7.25	6.25	5.50	
6.0	27.75	21.75	15.75	12.75	11.00	9.50	8.25	
8.0	37.25	29.00	21.00	17.00	14.50	12.75	11.00	
14.0	65.25	51.00	37.00	29.75	25.50	22.50	19.25	
20.0	93.00	73.00	52.75	42.75	36.50	32.00	27.50	
32.0	149.00	116.75	84.50	68.25	58.75	51.50	44.00	

Result: Load F [lbs]	L1 [inch]							
	6.0	12.0	18.0	24.0	30.0	36.0	42.0	48.0
x 4.0	644	322	215	161				
6.0	966	483	322	241				
8.0	644	429	322					
14.0			752	564				
20.0				805				
32.0								

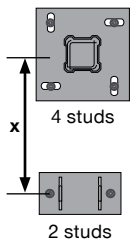

Result: L1 [inch]	F [lbs]							
	100	150	200	300	400	500	600	700
x 4.0				18.50	14.50	12.00	10.50	9.25
6.0				27.75	21.75	18.25	15.75	14.00
8.0				37.25	29.00	24.25	21.00	18.75
14.0				65.25	51.00	42.50	37.00	32.75
20.0				93.00	73.00	60.75	52.75	47.00
32.0				149.00	116.75	97.50	84.50	75.25

Result: Load F [lbs]	L1 [inch]							
	6.0	12.0	18.0	24.0	30.0	36.0	42.0	48.0
x 4.0	1,288	644	429	322				
6.0	1,933	966	644	483	386	322		
8.0		1,288	859	644	515	429	368	322
14.0			1,503	1,127	902	752	644	564
20.0				1,610	1,288	1,074	920	805
32.0						1,718	1,472	1,288

NOTE: load capacity used for calculation $N_{rec} = 810 \text{ lb (axial)} / V_{rec} = 970 \text{ lb (shear)}$

*X-BT-MR is the new generation X-BT

FASTENER SYSTEM	FASTENER OVERVIEW	FASTENER TECHNICAL DETAILS	APPLICATION OVERVIEW
HOW TO USE THIS DOCUMENT	DISCLAIMER		

FASTENING STRUT TO STEEL WITH X-BT-MR*

Two X-BT-MR Threaded studs

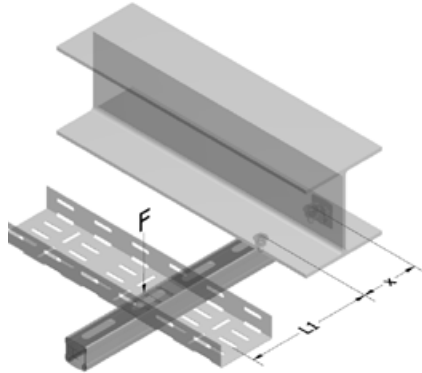

Application

- Fastening of cable trays, pipes on a horizontal cantilever support, fastened on a horizontal structure
- Support is fastened by two X-BT-MR (horizontal distance x)
- L1 is the distance of the load center to the vertical structure surface
- Load F is the acceptable total load (all dead load including)

Boundary conditions

- These values are ONLY reflecting capacity of X-BT-MR threaded stud. Structural analysis of support / structure is NOT in Hilti scope. See the detailed statements in disclaimer—2018/05/04
- Load F acting at the distance of L1 from structure surface

Technical assessment – maximum of L1 and F (depending on load F or lever arm length L1 and X-BT-MR distance x)

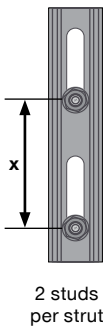

Result: L1 [inch]	F [lbs]							
	100	150	200	300	400	500	600	700
3.0	21.25	13.00	9.00	5.00	3.00	1.75	1.00	0.25
4.0	28.25	17.50	12.00	6.75	4.00	2.25	1.25	0.50
5.0	35.25	21.75	15.00	8.25	5.00	3.00	1.50	0.75
6.0	42.50	26.25	18.25	10.00	6.00	3.50	2.00	0.75
7.0	49.50	30.75	21.25	11.75	7.00	4.25	2.25	1.00
8.0	56.50	35.00	24.25	13.50	8.00	4.75	2.75	1.00

Result: Load F [lbs]	L1 [inch]							
	6.0	12.0	18.0	24.0	30.0	36.0	42.0	48.0
3.0	270	162	116	90	73	62	54	47
4.0	323	202	147	116	95	81	70	62
5.0	368	238	176	139	116	99	86	76
6.0	404	270	202	162	135	116	101	90
7.0	436	298	226	183	153	132	116	103
8.0	462	323	249	202	170	147	129	116

NOTE: load capacity used for calculation $N_{rec} = 810 \text{ lb (axial)} / V_{rec} = 970 \text{ lb (shear)}$

*X-BT-MR is the new generation X-BT

FASTENER SYSTEM	FASTENER OVERVIEW	FASTENER TECHNICAL DETAILS	APPLICATION OVERVIEW
HOW TO USE THIS DOCUMENT	DISCLAIMER		

FASTENING STRUT TO STEEL WITH X-BT-MR*

Two / Four X-BT-MR Threaded studs

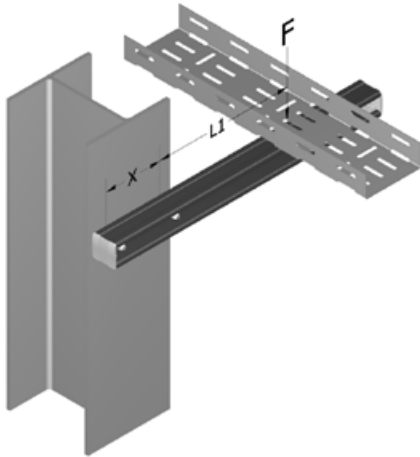

Application

- Fastening of cable trays, pipes on a horizontal cantilever support, fastened on a vertical structure
- Support is fastened by two X-BT-MR (horizontal distance x)
- L1 is the distance of the load center to the center of the fasteners
- Load F is the acceptable total load (all dead load including)

Boundary conditions

- These values are ONLY reflecting capacity of X-BT-MR threaded stud. Structural analysis of support / structure is NOT in Hilti scope. See the detailed statements in disclaimer—2018/05/04
- Shear load fully carried by one X-BT-MR (worst-case)
- Load F acting at the distance of L1 from structure surface

Technical assessment – maximum of L1 and F (depending on load F or lever arm length L1 and X-BT-MR distance x)

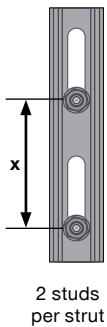

Result: L1 [inch]	F [lbs]							
	100	150	200	300	400	500	600	700
3.0	26.00	16.25	11.50	6.50	4.00	2.75	1.75	1.00
4.0	34.50	21.75	15.25	8.75	5.50	3.50	2.25	1.50
5.0	43.25	27.00	19.00	11.00	7.00	4.50	3.00	1.75
6.0	52.00	32.50	23.00	13.25	8.50	5.50	3.50	2.25
7.0	60.50	38.00	26.75	15.50	9.75	6.50	4.25	2.50
8.0	69.25	43.50	30.50	17.75	11.25	7.25	4.75	3.00

Result: Load F [lbs]	L1 [inch]							
	6.0	12.0	18.0	24.0	30.0	36.0	42.0	48.0
3.0	322	193	138	107	88	74	64	57
4.0	386	241	175	138	114	97	84	74
5.0	439	284	210	166	138	118	103	91
6.0	483	322	241	193	161	138	121	107
7.0	520	356	271	218	183	157	138	123
8.0	552	386	297	241	203	175	155	138

NOTE: load capacity used for calculation $N_{rec} = 810 \text{ lb (axial)} / V_{rec} = 970 \text{ lb (shear)}$

*X-BT-MR is the new generation X-BT

FASTENER SYSTEM	FASTENER OVERVIEW	FASTENER TECHNICAL DETAILS	APPLICATION OVERVIEW
HOW TO USE THIS DOCUMENT	DISCLAIMER		

FASTENING T-POST (CEILING) SUPPORT WITH X-BT-MR*

Two / Four X-BT-MR Threaded studs

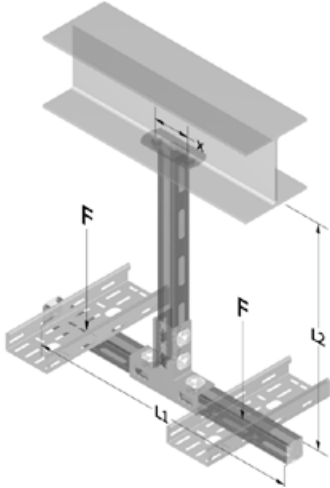

Application

- Fastening of cable trays, pipes on a T-Post support, which is fastened on a horizontal structure
- Support is fastened by two / four X-BT-MR (horizontal distance x)
- L1 is the total width of the T-Post, L2 is fix set to 1000 mm
- Load F is the acceptable total load (all dead load including)

Boundary conditions

- These values are ONLY reflecting capacity of X-BT-MR threaded stud. Structural analysis of support / structure is NOT in Hilti scope. See the detailed statements in disclaimer—2018/05/04
- 2 Load cases: load asymmetric acting in the center of one arm only, 30% acting as horizontal load

Technical assessment – maximum of L1 and F (depending on load F or lever arm length L1 and X-BT-MR distance x)

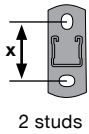

Result: L1 [inch]	F [lbs]							
	100	150	200	300	400	500	600	700
x [inch]	3.0	91.00	58.50					
	4.0	121.25	78.25	56.50				
	5.0	151.75	97.75	70.75				
	6.0	182.00	117.25	85.00				
	7.0	212.50	137.00	99.25	61.50			
	8.0	242.75	156.50	113.25	70.25			

Result: Load F [lbs]	L1 [inch]							
	6.0	12.0	18.0	24.0	30.0	36.0	42.0	48.0
x [inch]	3.0	172	172	172	172	172	172	172
	4.0	218	218	218	218	218	218	218
	5.0	260	260	260	260	260	260	260
	6.0	297	297	297	297	297	297	297
	7.0	332	332	332	332	332	332	332
	8.0	363	363	363	363	363	363	363

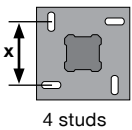

Result: L1 [inch]	F [lbs]							
	100	150	200	300	400	500	600	700
x [inch]	3.0	188.00	123.25	91.00	58.50			
	4.0	250.75	164.50	121.25	78.25	56.50		
	5.0	313.50	205.75	151.75	97.75	70.75	54.50	
	6.0	376.25	246.75	182.00	117.25	85.00	65.50	
	7.0	439.00	288.00	212.50	137.00	99.25	76.50	61.50
	8.0	501.75	329.25	242.75	156.50	113.25	87.50	70.25

Result: Load F [lbs]	L1 [inch]							
	6.0	12.0	18.0	24.0	30.0	36.0	42.0	48.0
x [inch]	3.0	312	312	312	312	312	312	312
	4.0	385	385	385	385	385	385	385
	5.0	448	448	448	448	448	448	448
	6.0	502	502	502	502	502	502	502
	7.0	550	550	550	550	550	550	550
	8.0	593	593	593	593	593	593	593

NOTE: load capacity used for calculation $N_{rec} = 810 \text{ lb (axial)} / V_{rec} = 970 \text{ lb (shear)}$

*X-BT-MR is the new generation X-BT

FASTENER SYSTEM	FASTENER OVERVIEW	FASTENER TECHNICAL DETAILS	APPLICATION OVERVIEW
HOW TO USE THIS DOCUMENT	DISCLAIMER		

FASTENING T-POST (FLOOR) SUPPORT WITH X-BT-MR*

Two / Four X-BT-MR Threaded studs

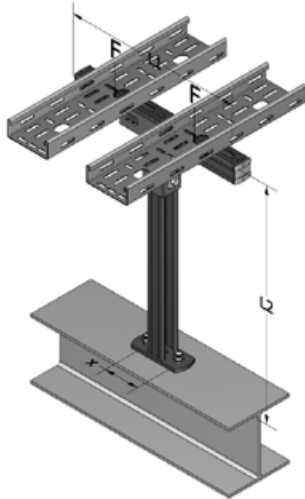

Application

- Fastening of cable trays, pipes on a T-Post support, which is fastened on a horizontal structure
- Support is fastened by two / four X-BT-MR (horizontal distance x)
- L1 is the total width of the T-Post, L2 is fix set to 1000 mm
- Load F is the acceptable total load (all dead load including)

Boundary conditions

- These values are ONLY reflecting capacity of X-BT-MR threaded stud. Structural analysis of support / structure is NOT in Hilti scope. See the detailed statements in disclaimer—2018/05/04
- 2 Load cases: load asymmetric acting in the center of one arm only, 30% acting as horizontal load

Technical assessment – maximum of L1 and F (depending on load F or lever arm length L1 and X-BT-MR distance x)

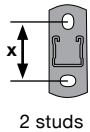

Result: L1 [inch]	F [lbs]							
	100	150	200	300	400	500	600	700
x [inch]	3.0	103.00	70.50					
	4.0	137.25	94.25	72.50				
	5.0	171.75	117.75	90.75	63.75			
	6.0	206.00	141.25	109.00	76.50			
	7.0	240.50	165.00	127.25	89.50	70.50		
	8.0	274.75	188.50	145.25	102.25	80.50		

Result: Load F [lbs]	L1 [inch]							
	6.0	12.0	18.0	24.0	30.0	36.0	42.0	48.0
x [inch]	3.0	193	193	193	193	193	193	193
	4.0	252	252	252	252	252	252	252
	5.0	310	310	310	310	310	310	310
	6.0	364	364	364	364	364	364	364
	7.0	417	417	417	417	417	417	417
	8.0	468	468	468	468	468	468	468

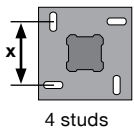

Result: L1 [inch]	F [lbs]							
	100	150	200	300	400	500	600	700
x [inch]	3.0	200.00	135.25					
	4.0	266.75	180.50	137.25				
	5.0	333.50	225.75	171.75	117.75			
	6.0	400.25	270.75	206.00	141.25			
	7.0	467.00	316.00	240.50	165.00	127.25		
	8.0	533.75	361.25	274.75	188.50	145.25	119.50	

Result: Load F [lbs]	L1 [inch]							
	6.0	12.0	18.0	24.0	30.0	36.0	42.0	48.0
x [inch]	3.0	386	386	386	386	386	386	386
	4.0	505	505	505	505	505	505	505
	5.0	619	619	619	619	619	619	619
	6.0	729	729	729	729	729	729	729
	7.0	835	835	835	835	835	835	835
	8.0	937	937	937	937	937	937	937

NOTE: load capacity used for calculation $N_{rec} = 810 \text{ lb (axial)} / V_{rec} = 970 \text{ lb (shear)}$

*X-BT-MR is the new generation X-BT

FASTENER SYSTEM	FASTENER OVERVIEW	FASTENER TECHNICAL DETAILS	APPLICATION OVERVIEW
HOW TO USE THIS DOCUMENT	DISCLAIMER		

FASTENING U-FRAME (CEILING) / TRAPEZE SUPPORT WITH X-BT-MR*

Two / Four X-BT-MR Threaded studs

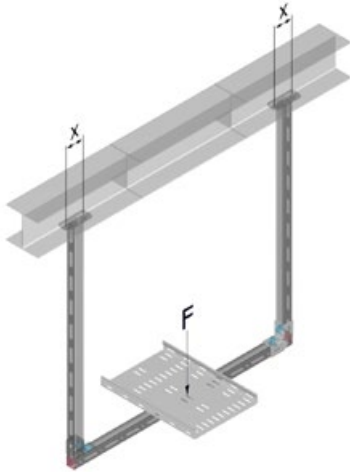

Application

- Fastening of cable trays, pipes on a U-Frame support, which is fastened on a horizontal structure
- Support is fastened by four X-BT-MR (2 fasteners per baseplate)
- Load F is the acceptable total load (all dead load including, acting in the center of the U-Frame)

Boundary conditions

- These values are ONLY reflecting capacity of X-BT-MR threaded stud. Structural analysis of support / structure is NOT in Hilti scope. See the detailed statements in disclaimer—2018/05/04
- Load acting in the center (U-Frame)

Technical assessment — maximum of F

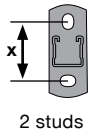

$F = N_{rec} \cdot \text{\#fasteners per post}$
 $F = 810 \text{ lb} \cdot 4$
 $F = 3,240 \text{ lb}$

NOTE: load capacity used for calculation $N_{rec} = 810 \text{ lb}$ (axial) / $V_{rec} = 970 \text{ lb}$ (shear)

*X-BT-MR is the new generation X-BT

FASTENER SYSTEM

FASTENER OVERVIEW

FASTENER TECHNICAL DETAILS

APPLICATION OVERVIEW

HOW TO USE THIS DOCUMENT

DISCLAIMER

FASTENING L-POST SUPPORT WITH X-BT-MR*

Two / Four X-BT-MR Threaded studs

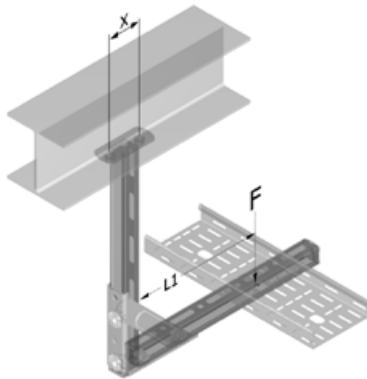

Application

- Fastening of cable trays, pipes on a L-Post support, which is fastened on a horizontal structure
- Support is fastened by two / four X-BT-MR (horizontal distance x)
- L1 is the distance of the load center to the vertical structure surface
- Load F is the acceptable total load (all dead load including)

Boundary conditions

- These values are ONLY reflecting capacity of X-BT-MR threaded stud. Structural analysis of support / structure is NOT in Hilti scope. See the detailed statements in disclaimer—2018/05/04
- Load F acting at the distance of L1 from structure surface

Technical assessment – maximum of L1 and F (depending on load F or lever arm length L1 and X-BT-MR distance x)

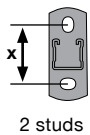

Result: L1 [inch]	F [lbs]								
	100	150	200	300	400	500	600	700	
x [inch]	3.0	22.75	14.50	10.50	6.50	4.50	3.25	2.50	1.75
	4.0	30.25	19.50	14.00	8.75	6.00	4.25	3.25	2.50
	5.0	37.75	24.25	17.50	10.75	7.50	5.50	4.00	3.25
	6.0	45.50	29.25	21.25	13.00	9.00	6.50	5.00	3.75
	7.0	53.00	34.25	24.75	15.25	10.50	7.75	5.75	4.50
	8.0	60.50	39.00	28.25	17.50	12.00	8.75	6.75	5.00

Result: Load F [lbs]	L1 [inch]								
	6.0	12.0	18.0	24.0	30.0	36.0	42.0	48.0	
x [inch]	3.0	323	180	124	95	77	65	56	49
	4.0	404	231	162	124	101	85	73	65
	5.0	476	279	197	153	124	105	91	80
	6.0	539	323	231	180	147	124	108	95
	7.0	596	365	263	206	169	143	124	110
	8.0	647	404	294	231	190	162	141	124

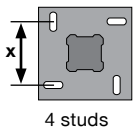

Result: L1 [inch]	F [lbs]								
	100	150	200	300	400	500	600	700	
x [inch]	3.0	47.00	30.75	22.75	14.50	10.50	8.00	6.50	5.25
	4.0	62.50	41.00	30.25	19.50	14.00	10.75	8.75	7.00
	5.0	78.25	51.25	37.75	24.25	17.50	13.50	10.75	9.00
	6.0	94.00	61.50	45.50	29.25	21.25	16.25	13.00	10.75
	7.0	109.75	72.00	53.00	34.25	24.75	19.00	15.25	12.50
	8.0	125.25	82.25	60.50	39.00	28.25	21.75	17.50	14.25

Result: Load F [lbs]	L1 [inch]								
	6.0	12.0	18.0	24.0	30.0	36.0	42.0	48.0	
x [inch]	3.0	647	359	249	190	154	129	112	98
	4.0	809	462	323	249	202	170	147	129
	5.0	952	558	395	305	249	210	182	160
	6.0	1,079	647	462	359	294	249	216	190
	7.0	1,192	731	527	412	338	287	249	220
	8.0	1,294	809	588	462	381	323	281	249

NOTE: load capacity used for calculation $N_{rec} = 810 \text{ lb (axial)} / V_{rec} = 970 \text{ lb (shear)}$

*X-BT-MR is the new generation X-BT

[FASTENER SYSTEM](#)
[FASTENER OVERVIEW](#)
[FASTENER TECHNICAL DETAILS](#)
[APPLICATION OVERVIEW](#)
[HOW TO USE THIS DOCUMENT](#)
[DISCLAIMER](#)

FASTENING EQUIPMENT SUPPORT WITH X-BT-MR*

Two / Four X-BT-MR Threaded studs

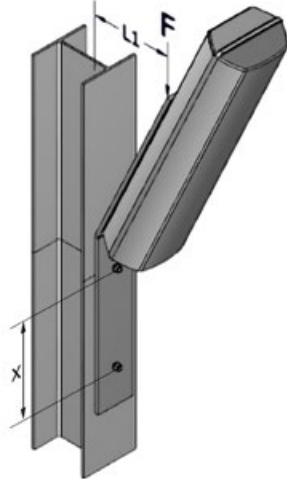

Application

- Fastening of lamps, signals, sensors on inclined cantilever support, fastened on a vertical structure
- Support is fastened by two / four X-BT-MR (vertical distance x)
- L1 is the distance of the load center (~middle of the load) to the vertical structure surface
- Load F is the acceptable total load (all dead load including)

Boundary conditions

- These values are ONLY reflecting capacity of X-BT-MR threaded stud. Structural analysis of support / structure is NOT in Hilti scope. See the detailed statements in disclaimer—2018/05/04
- Shear load fully carried by one / two top X-BT-MR (worst-case)
- Load F acting at the distance of L1 from structure surface

Technical assessment – maximum of L1 and F (depending on load F or lever arm length L1 and X-BT-MR distance x)

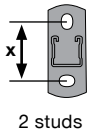

Result: L1 [inch]	F [lbs]								
	100	150	200	300	400	500	600	700	
x [inch]	3.0	21.75	13.50	9.50	5.50	3.50	2.25	1.50	0.75
	4.0	29.00	18.00	12.75	7.25	4.50	3.00	2.00	1.25
	5.0	36.25	22.75	16.00	9.25	5.75	3.75	2.50	1.50
	6.0	43.50	27.25	19.25	11.00	7.00	4.50	3.00	1.75
	7.0	50.75	31.75	22.25	13.00	8.25	5.25	3.50	2.00
	8.0	58.00	36.25	25.50	14.75	9.25	6.00	4.00	2.50

Result: Load F [lbs]	L1 [inch]								
	6.0	12.0	18.0	24.0	30.0	36.0	42.0	48.0	
x [inch]	3.0	285	167	118	91	75	63	54	48
	4.0	346	211	151	118	97	82	71	63
	5.0	397	250	182	143	118	101	88	77
	6.0	440	285	211	167	138	118	103	91
	7.0	477	317	237	190	158	135	118	105
	8.0	510	346	262	211	176	151	133	118

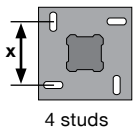

Result: L1 [inch]	F [lbs]								
	100	150	200	300	400	500	600	700	
x [inch]	3.0	43.50	27.25	19.25	11.00	7.00	4.50	3.00	1.75
	4.0	58.00	36.25	25.50	14.75	9.25	6.00	4.00	2.50
	5.0	72.50	45.50	32.00	18.50	11.75	7.75	5.00	3.00
	6.0	87.00	54.50	38.50	22.25	14.00	9.25	6.00	3.75
	7.0	101.50	63.75	44.75	26.00	16.50	10.75	7.00	4.25
	8.0	116.00	72.75	51.25	29.75	18.75	12.50	8.00	5.00

Result: Load F [lbs]	L1 [inch]								
	6.0	12.0	18.0	24.0	30.0	36.0	42.0	48.0	
x [inch]	3.0	570	334	237	183	149	126	109	96
	4.0	692	422	303	237	194	164	143	126
	5.0	794	500	365	287	237	201	175	155
	6.0	881	570	422	334	277	237	206	183
	7.0	955	634	475	379	316	271	237	210
	8.0	1,019	692	524	422	353	303	266	237

NOTE: load capacity used for calculation $N_{rec} = 810 \text{ lb (axial)} / V_{rec} = 970 \text{ lb (shear)}$

*X-BT-MR is the new generation X-BT

FASTENER SYSTEM	FASTENER OVERVIEW	FASTENER TECHNICAL DETAILS	APPLICATION OVERVIEW
HOW TO USE THIS DOCUMENT	DISCLAIMER		

FASTENING JUNCTION BOXES / SWITCHES WITH X-BT-MR*

X-BT-MR Threaded stud

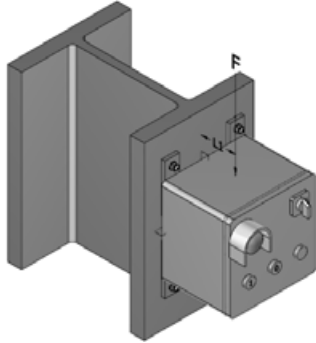

Application

- Fastening of junction boxes, switches on a vertical structure
- Element is fastened by X-BT-MR

Boundary conditions

- These values are ONLY reflecting capacity of X-BT-MR threaded stud. Structural analysis of support / structure is NOT in Hilti scope. See the detailed statements in disclaimer—2018/05/04
- Technical data are based on technical data binder for X-BT-MR (06 / 2018), always refer to latest technical data binder for X-BT-MR

Technical data — always refer to latest technical data binder for X-BT-MR

Recommended load	X-BT-MR		
Drill hole type and base material thickness	Pilot hole, $t_{II} \geq 8 \text{ mm (0.31")}$		
Base material	Steel S235 A36	Steel S355 Grade 50	Cast iron with spheroidal graphite
Tension, N_{rec} [kN / lb]	3.6 / 810	4.6 / 1030	1.0 / 230
Shear, V_{rec} [kN / lb]	4.3 / 970	5.3 / 1190	1.5 / 340
Moment, M_{rec} [Nm / ft-lb]	20.0 / 14.8	20.0 / 14.8	16.0 / 11.5

Design resistance	X-BT-MR		
Drill hole type and base material thickness	Pilot hole, $t_{II} \geq 8 \text{ mm (0.31")}$		
Base material	Steel S235 A36	Steel S355 Grade 50	Cast iron with spheroidal graphite
Tension, N_{Rd} [kN / lb]	5.0	6.5	1.6
Shear, V_{Rd} [kN / lb]	6.0	7.5	2.4
Moment, M_{Rd} [Nm / ft-lb]	28.0	28.0	26.0

Conditions for recommended loads

- Global factor of safety for static pull-out > 3 (based on 5% fractile value), ≥ 5 (based on mean value)
- Minimum edge distance = 6 mm [$\frac{1}{4}$ "]
- Effect of base metal vibration and stress considered
- Redundancy (multiple fastening) must be provided
- Recommended loads in the table refer to the resistance of the individual fastening and may not be the same as the loads F_N and F_V acting on the fastened part.

Note: if relevant, prying forces need to be considered in design, see example. Moment acting on fastener shank only in case of a gap between base and fastened material.

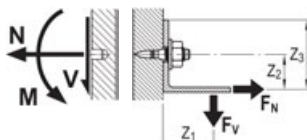

Recommended interaction formula for combined loading — steel and cast iron base material

Combined loading situation	Interaction formula
V-N (shear and tension)	$\frac{V}{V_{rec}} + \frac{N}{N_{rec}} \leq 1.2$ with $\frac{V}{V_{rec}} \leq 1.0$ and $\frac{N}{N_{rec}} \leq 1.0$
V-M (shear and bending)	$\frac{V}{V_{rec}} + \frac{M}{M_{rec}} \leq 1.2$ with $\frac{V}{V_{rec}} \leq 1.0$ and $\frac{M}{M_{rec}} \leq 1.0$
N-M (tension and bending)	$\frac{N}{N_{rec}} + \frac{M}{M_{rec}} \leq 1.0$
V-N-M (shear, tension and bending)	$\frac{V}{V_{rec}} + \frac{N}{N_{rec}} + \frac{M}{M_{rec}} \leq 1.0$

*X-BT-MR is the new generation X-BT

X-BT-MR* CATALOG PAGES

Description	Base Material	Environment	Item Number
Threaded stud X-BT-MR M8/14 SN 8	Steel	Highly corrosive	2194339
Threaded stud X-BT-MR M6/14 SN 8	Steel	Highly corrosive	2194337
Threaded stud X-BT-MR W6/14 SN 8	Steel	Highly corrosive	2194338
Threaded stud X-BT-MR M10/15 SN 8	Steel	Highly corrosive	2194340
Threaded stud X-BT-MR W10/15 SN 8	Steel	Highly corrosive	2194341

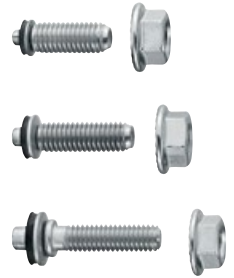

Tool Kit	Item Number
X-BT tool set*	Local item
DX 351-BT powder-actuated tool	Local item
Piston X-351 BT	378676
Fastener guide BT FG M1024 for metric studs	378674
Fastener guide BT FG W1024 for Whitworth studs	378673
6.8/11 M10 brown cartridge	412689
SF BT 22-A cordless drill	2123719



Accessories	Item Number
Stepped drill bit TX-BT 4.7/7-80	2197930
Nut setter S-NS 13C (for use with M8 flange nuts)	2149244
Socket wrench insert X-NSD 1/4" - 10 mm (for M6)	2197934
Socket wrench insert X-NSD 1/4" - 25/64" (for W6)	2197935
Nut setter S-NS 15C (for M10)	2149245
Nut setter S-NS 9/16" C95/3 3/4" (for W10)	2149246
Torque tool X-BT 1/4" 20 Nm / 14.8 ft-lb	2212510



*X-BT-MR is the new generation X-BT





S-BT-MR /
S-BT-MF MT /
S-BT-MF
THREADED STUD

Imperial

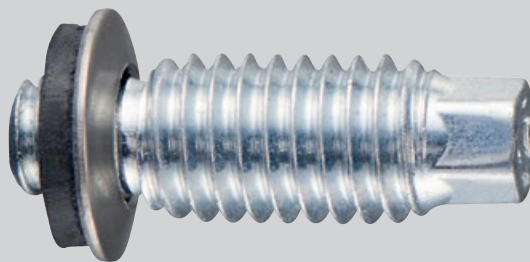

S-BT HL TECHNICAL DATA USED FOR THE FOLLOWING CALCULATIONS

S-BT HL technical data

- **Drill hole type / base material:** Pilot hole, $t_{II} \geq 6 \text{ mm (0.24")}$ or drill through hole, $5 \text{ mm (0.20")} \leq t_{II} < 6 \text{ mm (0.24")}$
- **Base material:** Steel S235 / A36 (higher steel strength is possible, increases the rec. load)

Recommended interaction for combined loads

S-BT-MR HL

$N_{rec} = 810 \text{ lb (axial)} / V_{rec} = 900 \text{ lb (shear)}$
 Washer diameter = 12 mm (0.47")
 For opening > 13 mm (1/2")

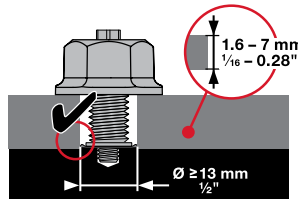

S-BT-MF MT HL

$N_{rec} = 810 \text{ lb (axial)} / V_{rec} = 900 \text{ lb (shear)}$
 Washer diameter = 12 mm (0.47")
 For opening > 13 mm (1/2")

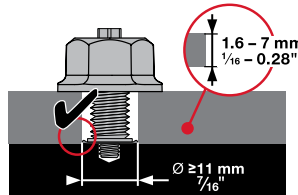

S-BT-MF HL

$N_{rec} = 810 \text{ lb (axial)} / V_{rec} = 618 \text{ lb (shear)}$
 Washer diameter = 10 mm (0.39")
 For opening > 11 mm (7/16")

V-N (shear and tension)

$$\frac{V}{V_{rec}} + \frac{N}{N_{rec}} \leq 1.0 \quad \text{with} \quad \frac{V}{V_{rec}} \leq 1.0 \quad \text{and} \quad \frac{N}{N_{rec}} \leq 1.0$$

For further technical data refer to the latest technical information (DFTM and S-BT HL specification binder)

FASTENING CANTILEVER SUPPORT WITH S-BT HL

Two / Four S-BT-MR HL / S-BT-MF MT HL Threaded studs

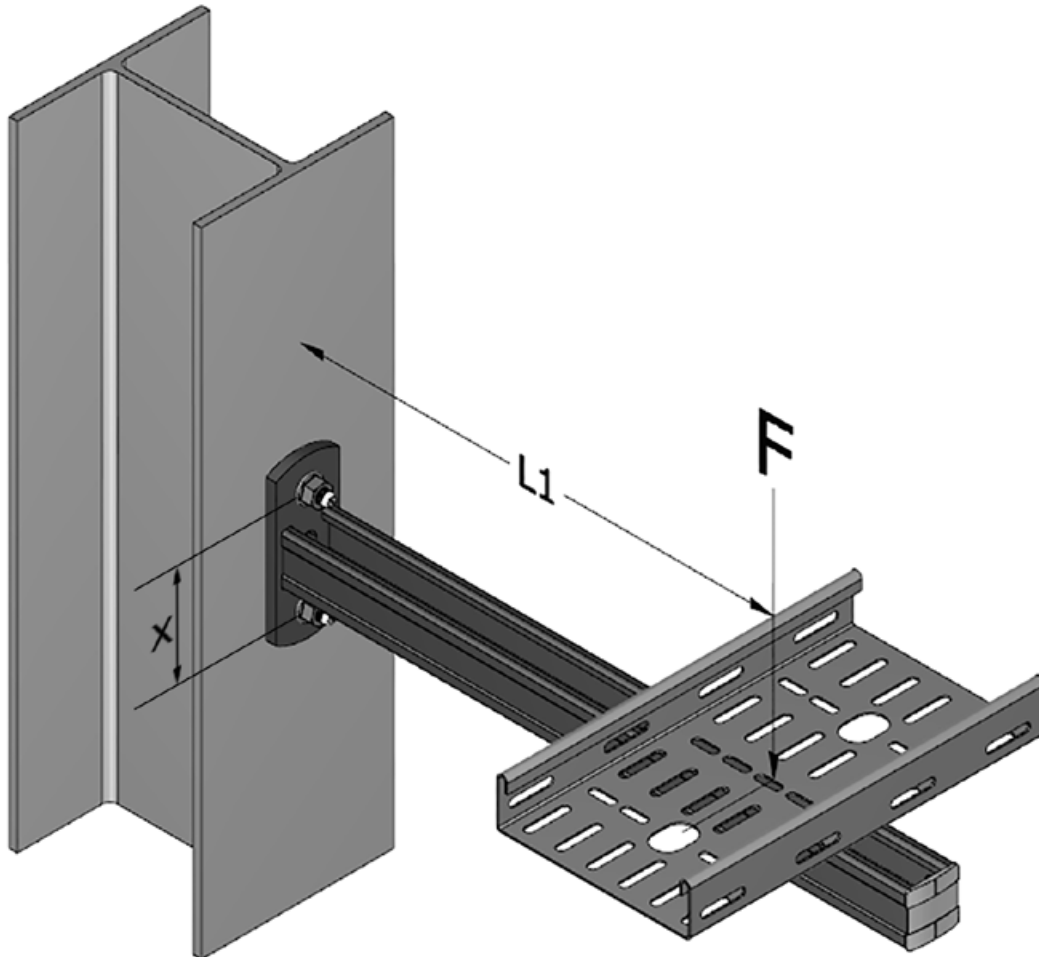

Application

- Fastening of cable trays, pipes on a horizontal cantilever support, fastened on a vertical structure
- Support is fastened by two / four S-BT HL on both support and brace baseplate with distance x
- $L1$ is the distance of the load center to the vertical structure surface
- Load F is the acceptable total load (all dead load including)

Boundary conditions

- These values are ONLY reflecting capacity of S-BT HL threaded stud. Structural analysis of support / structure is NOT in Hilti scope. See the detailed statements in disclaimer—2018/05/04
- Shear load fully carried by one / two top S-BT HL (worst-case)
- Load F acting at the distance of $L1$ from structure surface

Technical assessment – maximum of $L1$ and F (depending on load F or lever arm length $L1$ and S-BT HL distance x)

FASTENER SYSTEM

FASTENER OVERVIEW

FASTENER TECHNICAL DETAILS



APPLICATION OVERVIEW

HOW TO USE THIS DOCUMENT

DISCLAIMER

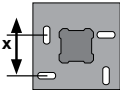

FASTENING CANTILEVER SUPPORT WITH S-BT HL

Two / Four S-BT-MR HL / S-BT-MF MT HL Threaded studs

 2 studs		Result:		F [lbs]							Result: Load F [lbs]		L1 [inch]									
		L1 [inch]		100	150	200	300	400	500	600			700	6	12	18	24	30	36	42	48	
 4 studs	x	3	24	12	7	5	3	2	2	1	3	335	198	135	101	81	67	58	50			
		4	32	16	9	6	4	3	2	1	4	404	249	180	135	108	90	77	67			
	[inch]	5	41	20	12	8	5	4	3	2	5	462	294	216	168	135	112	96	84			
		6	49	24	14	9	6	4	3	2	6	511	335	249	198	162	135	116	101			
		7	57	28	16	11	7	5	4	2	7	552	371	280	224	187	157	135	118			
		8	65	32	19	12	8	6	4	3	8	588	404	308	249	209	180	154	135			
				Result:		F [lbs]							Result:		L1 [inch]							
				L1 [mm]		100	150	200	300	400	500	600	700	Load F [kg]		6	12	18	24	30	36	42
 2 studs	x	3	49	24	16	12	9	7	6	5	3	670	396	270	202	162	135	116	101			
		4	65	32	22	16	12	9	7	6	4	809	498	359	270	216	180	154	135			
	[inch]	5	81	40	27	20	15	12	9	8	5	924	588	431	337	270	225	192	168			
		6	97	49	32	24	18	14	11	9	6	1,022	670	498	396	323	270	231	202			
		7	113	57	38	28	21	16	13	11	7	1,105	743	559	448	374	315	270	236			
		8	129	65	43	32	24	19	15	12	8	1,177	809	616	498	418	359	308	270			

NOTE: load capacity used for calculation $N_{rec} = 810 \text{ lb (axial)} / V_{rec} = 900 \text{ lb (shear)}$

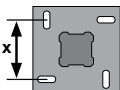
Two / Four S-BT-MF HL Threaded studs

 2 studs		Result:		F [lbs]							Result: Load F [kg]		L1 [inch]									
		L1 [mm]		100	150	200	300	400	500	600			700	6	12	18	24	30	36	42	48	
 4 studs	x	3	24	11	6	3	2	1			3	293	183	133	101	81	67	58	50			
		4	32	14	8	4	3	1			4	345	225	167	133	108	90	77	67			
	[inch]	5	40	18	10	6	3	2			5	387	262	198	159	133	112	96	84			
		6	49	21	12	7	4	2			6	420	293	225	183	154	133	116	101			
		7	57	25	13	8	4	2			7	448	321	250	205	174	150	133	118			
		8	65	28	15	9	5	2			8	471	345	273	225	192	167	148	133			
				Result:		F [lbs]							Result:		L1 [inch]							
				L1 [mm]		100	150	200	300	400	500	600	700	Load F [kg]		6	12	18	24	30	36	42
		→ Load in [kN]		0.49	0.74	0.98	1.23	1.47	1.96	2.45	2.94											
 2 studs	x	3	49	24	15	11	8	6	4	3	3	587	366	265	202	162	135	116	101			
		4	65	32	21	14	10	8	6	4	4	691	450	334	265	216	180	154	135			
	[inch]	5	81	40	26	18	13	10	7	6	5	774	523	396	318	265	225	192	168			
		6	97	49	31	21	15	12	9	7	6	841	587	450	366	308	265	231	202			
		7	113	57	36	25	18	13	10	8	7	896	642	500	410	347	301	265	236			
		8	129	65	41	28	21	15	12	9	8	943	691	545	450	384	334	296	265			

NOTE: load capacity used for calculation $N_{rec} = 810 \text{ lb (axial)} / V_{rec} = 618 \text{ lb (shear)}$

- FASTENER SYSTEM
- FASTENER OVERVIEW
- FASTENER TECHNICAL DETAILS
- APPLICATION OVERVIEW
- HOW TO USE THIS DOCUMENT
- DISCLAIMER

FASTENING BRACED CANTILEVER SUPPORT WITH S-BT HL

Two / Four S-BT-MR HL / S-BT-MF MT HL Threaded studs

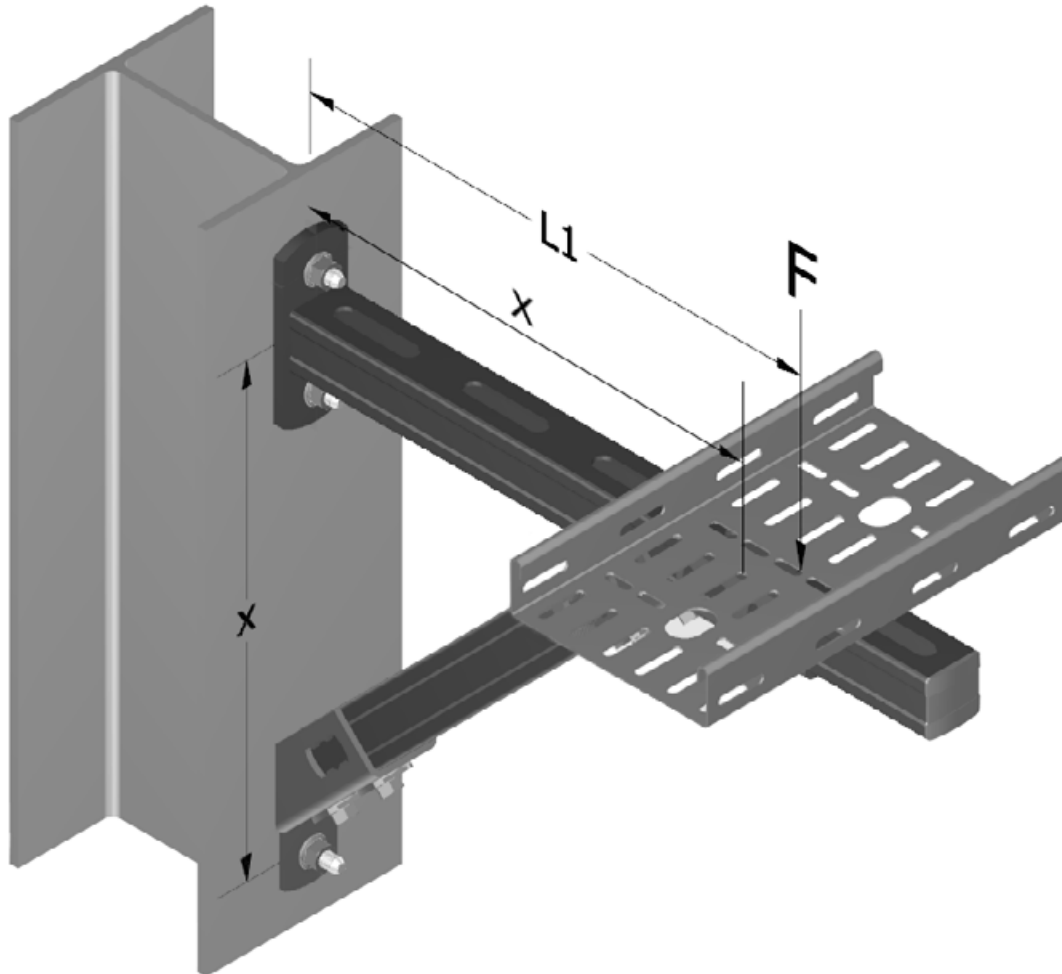

Application

- Fastening of cable trays, pipes on a horizontal, braced cantilever support, fastened on a vertical structure
- Support is fastened by three / six S-BT HL on both support and brace baseplate with distance x
- $L1$ is the distance of the load center to the vertical structure surface, the angle of the brace is 45°
- Load F is the acceptable total load (all dead load including)

Boundary conditions

- These values are ONLY reflecting capacity of S-BT HL threaded stud. Structural analysis of support / structure is NOT in Hilti scope. See the detailed statements in disclaimer—2018/05/04
- Shear load fully carried by one / two top S-BT HL (worst-case)
- Load F acting at the distance of $L1$ from structure surface

Technical assessment – maximum of $L1$ and F (depending on load F or lever arm length $L1$ and baseplate distance x)

[FASTENER SYSTEM](#)

[FASTENER OVERVIEW](#)

[FASTENER TECHNICAL DETAILS](#)

[APPLICATION OVERVIEW](#)

[HOW TO USE THIS DOCUMENT](#)

[DISCLAIMER](#)

FASTENING BRACED CANTILEVER SUPPORT WITH S-BT HL

Two / Four S-BT-MR HL / S-BT-MF MT HL Threaded studs

Result:		F [lbs]							
L1 [inch]		100	150	200	300	400	500	600	700
x [inch]	3		16	12	9	7	6	5	4
	4		25	18	13	11	9	8	7
	5		33	24	18	14	12	10	9
	6		58	41	31	25	21	18	16
	7		82	59	45	36	30	26	22
	8		132	95	72	58	48	41	36

Result:		L1 [inch]							
Load F [lbs]		6	12	18	24	30	36	42	48
x [mm]	3		599	300	200	150			
	4		899	449	300	225			
	5			599	399	300			
	6				699	524			
	7					749			
	8								

Result:		F [lbs]							
L1 [mm]		100	150	200	300	400	500	600	700
x [inch]	3			21	16	14	12	10	9
	4			32	25	21	18	15	13
	5			42	33	27	24	21	18
	6			74	58	48	41	36	31
	7			105	82	68	59	51	45
	8			169	132	109	95	82	72

Result:		L1 [inch]							
Load F [kg]		6	12	18	24	30	36	42	48
x [mm]	3		1,198	599	399	300			
	4		1,798	899	599	449	359	300	
	5			1,198	799	599	479	399	342
	6				1,398	1,049	839	699	599
	7					1,498	1,198	999	856
	8							1,598	1,370

NOTE: load capacity used for calculation $N_{rec} = 810 \text{ lb (axial)} / V_{rec} = 900 \text{ lb (shear)}$

Two / Four S-BT-MF HL Threaded studs

Result:		F [lbs]							
L1 [mm]		100	150	200	300	400	500	600	700
x [inch]	3		24	12	8	6	5	4	
	4		37	19	12	9	7	6	
	5		49	25	16	12	10	8	
	6		85	43	29	22	17	14	
	7		122	62	41	31	25	21	
	8		195	99	66	49	40	33	

Result:		L1 [inch]							
Load F [kg]		6	12	18	24	30	36	42	48
x [mm]	3		412	206	137	103			
	4		618	309	206	154			
	5			412	274	206			
	6				481	360			
	7					515			
	8								

Result:		F [lbs]							
L1 [mm]		100	150	200	300	400	500	600	700
x [inch]	3			24	16	12	10	8	7
	4			37	25	19	15	12	11
	5			49	33	25	20	16	14
	6			85	58	43	35	29	25
	7			122	82	62	49	41	35
	8			195	132	99	79	66	57

Result:		L1 [inch]							
Load F [kg]		6	12	18	24	30	36	42	48
x [mm]	3		824	412	274	206			
	4		1,236	618	412	309	247	206	
	5			824	549	412	330	274	235
	6				961	721	577	481	412
	7					1,030	824	687	588
	8							1,099	942

NOTE: load capacity used for calculation $N_{rec} = 810 \text{ lb (axial)} / V_{rec} = 618 \text{ lb (shear)}$

[FASTENER SYSTEM](#)
[FASTENER OVERVIEW](#)
[FASTENER TECHNICAL DETAILS](#)
[APPLICATION OVERVIEW](#)
[HOW TO USE THIS DOCUMENT](#)
[DISCLAIMER](#)

FASTENING STRUT TO STEEL WITH S-BT HL

Two / Four S-BT-MR HL / S-BT-MF MT HL Threaded studs

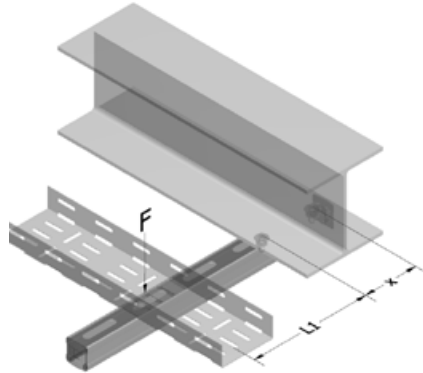

Application

- Fastening of cable trays, pipes on a horizontal cantilever support, fastened on a horizontal structure
- Support is fastened by two S-BT HL (horizontal distance x)
- L1 is the distance of the load center to the vertical structure surface
- Load F is the acceptable total load (all dead load including)

Boundary conditions

- These values are ONLY reflecting capacity of S-BT HL threaded stud. Structural analysis of support / structure is NOT in Hilti scope. See the detailed statements in disclaimer—2018/05/04
- Load F acting at the distance of L1 from structure surface

S-BT-MR HL / S-BT-MF MT HL

Technical assessment — maximum of L1 and F (depending on load F or lever arm length L1 and S-BT HL distance x)

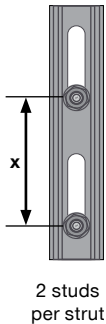

Result:		F [lbs]							
L1 [inch]		100	150	200	300	400	500	600	700
x [inch]	3.0	21	9	5	3	2	1	0	0
	4.0	28	12	7	4	2	1	1	0
	5.0	35	15	8	5	3	2	1	0
	6.0	43	18	10	6	4	2	1	0
	7.0	50	21	12	7	4	2	1	0
	8.0	57	24	14	8	5	3	1	0

Result:		L1 [inch]							
Load F [lbs]		6.0	12.0	18.0	24.0	30.0	36.0	42.0	48.0
x [inch]	3.0	270	162	116	90	73	62	54	47
	4.0	323	202	147	116	95	81	70	62
	5.0	368	238	176	139	116	99	86	76
	6.0	404	270	202	162	135	116	101	90
	7.0	436	298	226	183	153	132	116	103
	8.0	462	323	249	202	170	147	129	116

NOTE: load capacity used for calculation $N_{rec} = 810$ lb (axial) / $V_{rec} = 900$ lb (shear)

Two S-BT-MF HL Threaded studs

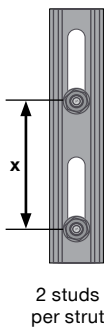

Result:		F [lbs]							
L1 [inch]		100	150	200	300	400	500	600	700
x [inch]	3.0	21	9	5	3	2	1	0	0
	4.0	28	12	7	4	2	1	1	0
	5.0	35	15	8	5	3	2	1	0
	6.0	43	18	10	6	4	2	1	0
	7.0	50	21	12	7	4	2	1	0
	8.0	57	24	14	8	5	3	1	0

Result:		L1 [inch]							
Load F [lbs]		6.0	12.0	18.0	24.0	30.0	36.0	42.0	48.0
x [inch]	3.0	270	162	116	90	73	62	54	47
	4.0	323	202	147	116	95	81	70	62
	5.0	368	238	176	139	116	99	86	76
	6.0	404	270	202	162	135	116	101	90
	7.0	436	298	226	183	153	132	116	103
	8.0	462	323	249	202	170	147	129	116

NOTE: load capacity used for calculation $N_{rec} = 810$ lb (axial) / $V_{rec} = 618$ lb (shear)

[FASTENER SYSTEM](#)
[FASTENER OVERVIEW](#)
[FASTENER TECHNICAL DETAILS](#)
[APPLICATION OVERVIEW](#)
[HOW TO USE THIS DOCUMENT](#)
[DISCLAIMER](#)

FASTENING STRUT TO STEEL WITH S-BT HL

Two / Four S-BT-MR HL / S-BT-MF MT HL Threaded studs

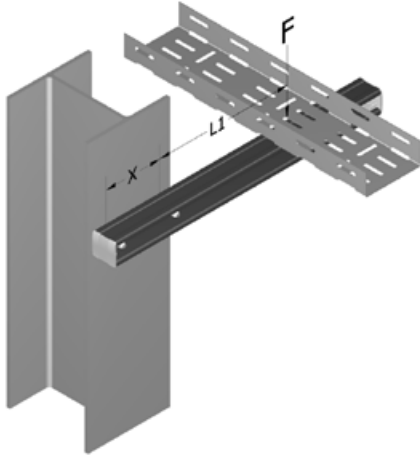

Application

- Fastening of cable trays, pipes on a horizontal cantilever support, fastened on a vertical structure
- Support is fastened by two S-BT HL (horizontal distance x)
- L1 is the distance of the load center to the center of the fasteners
- Load F is the acceptable total load (all dead load including)

Boundary conditions

- These values are ONLY reflecting capacity of S-BT HL threaded stud. Structural analysis of support / structure is NOT in Hilti scope. See the detailed statements in disclaimer—2018/05/04
- Shear load fully carried by one S-BT HL (worst-case)
- Load F acting at the distance of L1 from structure surface

S-BT-MR HL / S-BT-MF MT HL

Technical assessment — maximum of L1 and F (depending on load F or lever arm length L1 and S-BT HL distance x)

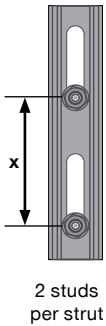

2 studs per strut

Result: L1 [inch]		F [lbs]							
		100	150	200	300	400	500	600	700
x [inch]	3.0	24	10	6	4	2	1	1	0
	4.0	32	14	8	5	3	2	1	0
	5.0	40	17	10	6	4	2	1	1
	6.0	48	21	12	7	5	3	2	1
	7.0	56	24	14	9	6	3	2	1
	8.0	64	28	16	10	6	4	2	1

Result: Load F [lbs]		L1 [inch]							
		6.0	12.0	18.0	24.0	30.0	36.0	42.0	48.0
x [inch]	3.0	24.0	10.5	6.0	3.7	2.4	1.5	0.9	0.4
	4.0	32.0	14.0	8.0	5.0	3.2	2.0	1.1	0.5
	5.0	40.0	17.5	10.0	6.2	4.0	2.5	1.4	0.6
	6.0	48.0	21.0	12.0	7.5	4.8	3.0	1.7	0.7
	7.0	55.9	24.5	14.0	8.7	5.6	3.5	2.0	0.9
	8.0	63.9	28.0	16.0	10.0	6.4	4.0	2.3	1.0

NOTE: load capacity used for calculation $N_{rec} = 810 \text{ lb (axial)} / V_{rec} = 900 \text{ lb (shear)}$

Two S-BT-MF HL Threaded studs

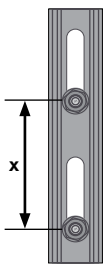

2 studs per strut

Result: L1 [inch]		F [lbs]							
		100	150	200	300	400	500	600	700
x [inch]	3.0	16	6	3	2	1	0		
	4.0	21	8	4	2	1	0		
	5.0	26	10	5	3	1	0		
	6.0	31	13	6	3	1	0		
	7.0	36	15	7	4	2	0		
	8.0	41	17	8	4	2	0		

Result: Load F [lbs]		L1 [inch]							
		6.0	12.0	18.0	24.0	30.0	36.0	42.0	48.0
x [inch]	3.0	206	123	88	69	56	47	41	36
	4.0	247	154	112	88	73	62	54	47
	5.0	281	182	134	106	88	75	66	58
	6.0	309	206	154	123	103	88	77	69
	7.0	333	228	173	139	117	101	88	78
	8.0	353	247	190	154	130	112	99	88

NOTE: load capacity used for calculation $N_{rec} = 810 \text{ lb (axial)} / V_{rec} = 618 \text{ lb (shear)}$

[FASTENER SYSTEM](#)
[FASTENER OVERVIEW](#)
[FASTENER TECHNICAL DETAILS](#)
[APPLICATION OVERVIEW](#)
[HOW TO USE THIS DOCUMENT](#)
[DISCLAIMER](#)

FASTENING T-POST (CEILING) SUPPORT WITH S-BT HL

Two / Four S-BT-MR HL / S-BT-MF MT HL Threaded studs

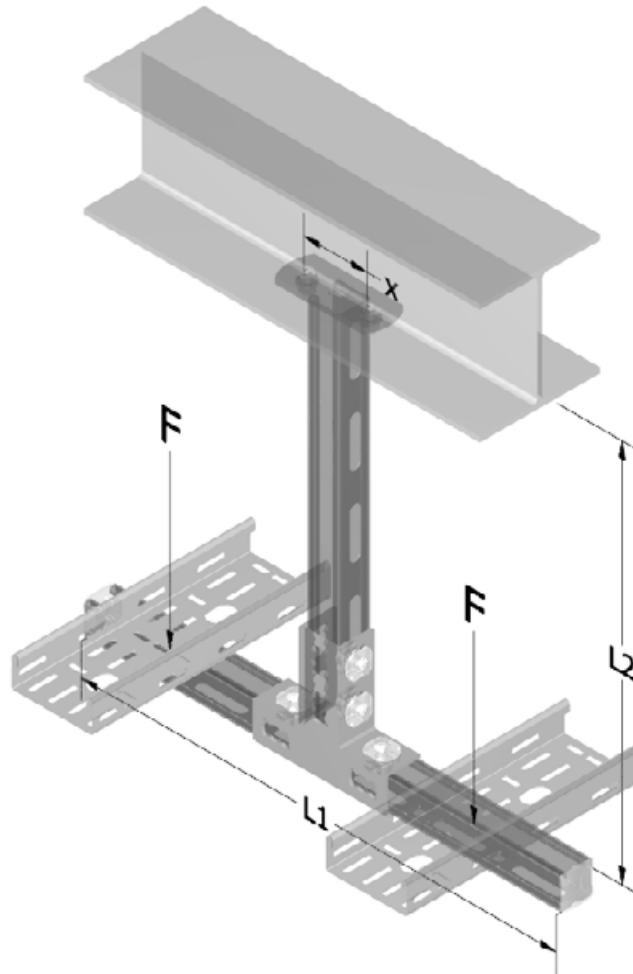

Application

- Fastening of cable trays, pipes on a T-Post support, which is fastened on a horizontal structure
- Support is fastened by two / four S-BT HL (horizontal distance x)
- $L1$ is the total width of the T-Post, $L2$ is fix set to 1000 mm
- Load F is the acceptable total load (all dead load including)

Boundary conditions

- These values are ONLY reflecting capacity of S-BT HL threaded stud. Structural analysis of support / structure is NOT in Hilti scope. See the detailed statements in disclaimer—2018/05/04
- 2 Load cases: load asymmetric acting in the center of one arm only, 30% acting as horizontal load

Technical assessment – maximum of $L1$ and F (depending on load F or lever arm length $L1$ and S-BT HL distance x)

FASTENER SYSTEM

FASTENER OVERVIEW

FASTENER TECHNICAL DETAILS

APPLICATION OVERVIEW

HOW TO USE THIS DOCUMENT

DISCLAIMER

FASTENING T-POST (CEILING) SUPPORT WITH S-BT HL

Two / Four S-BT-MR HL / S-BT-MF MT HL Threaded studs

Result:		F [lbs]							
L1 [inch]		100	150	200	300	400	500	600	700
3	2 studs	91							
	1 stud								
4	2 studs	121	57						
	1 stud								
5	2 studs	152	71						
	1 stud								
6	2 studs	182	85	53					
	1 stud								
7	2 studs	213	99	62					
	1 stud								
8	2 studs	243	113	70					
	1 stud								

Result:		L1 [inch]							
Load F [lbs]		6	12	18	24	30	36	42	48
3	2 studs	182	182	182	182	182	182	182	180
	1 stud								
4	2 studs	234	234	234	234	234	234	234	231
	1 stud								
5	2 studs	283	283	283	283	283	283	283	279
	1 stud								
6	2 studs	328	328	328	328	328	328	328	323
	1 stud								
7	2 studs	370	370	370	370	370	370	370	365
	1 stud								
8	2 studs	409	409	409	409	409	409	409	404
	1 stud								

Result:		F [lbs]							
L1 [mm]		100	150	200	300	400	500	600	700
3	4 studs	188	91	59					
	2 studs								
4	4 studs	251	121	78	57				
	2 studs								
5	4 studs	314	152	98	71	55			
	2 studs								
6	4 studs	376	182	117	85	66	53		
	2 studs								
7	4 studs	439	213	137	99	77	62	51	
	2 studs								
8	4 studs	502	243	157	113	88	70	58	
	2 studs								

Result:		L1 [inch]							
Load F [kg]		6	12	18	24	30	36	42	48
3	4 studs	328	328	328	328	328	328	328	328
	2 studs								
4	4 studs	409	409	409	409	409	409	409	409
	2 studs								
5	4 studs	481	481	481	481	481	481	481	481
	2 studs								
6	4 studs	545	545	545	545	545	545	545	545
	2 studs								
7	4 studs	602	602	602	602	602	602	602	602
	2 studs								
8	4 studs	653	653	653	653	653	653	653	653
	2 studs								

NOTE: load capacity used for calculation $N_{rec} = 810 \text{ lb (axial)} / V_{rec} = 900 \text{ lb (shear)}$

Two / Four S-BT-MF HL Threaded studs

Result:		F [lbs]							
L1 [mm]		100	150	200	300	400	500	600	700
3	2 studs	91							
	1 stud								
4	2 studs	121	57						
	1 stud								
5	2 studs	152	71						
	1 stud								
6	2 studs	182	85	53					
	1 stud								
7	2 studs	213	99	62					
	1 stud								
8	2 studs	243	113	70					
	1 stud								

Result:		L1 [inch]							
Load F [kg]		6	12	18	24	30	36	42	48
3	2 studs	182	182	182	182	182	182	182	180
	1 stud								
4	2 studs	234	234	234	234	234	234	234	231
	1 stud								
5	2 studs	283	283	283	283	283	283	283	279
	1 stud								
6	2 studs	328	328	328	328	328	328	328	323
	1 stud								
7	2 studs	370	370	370	370	370	370	370	365
	1 stud								
8	2 studs	409	409	409	409	409	409	409	404
	1 stud								

Result:		F [lbs]							
L1 [mm]		100	150	200	300	400	500	600	700
3	4 studs	188	91	59					
	2 studs								
4	4 studs	251	121	78	57				
	2 studs								
5	4 studs	314	152	98	71	55			
	2 studs								
6	4 studs	376	182	117	85	66	53		
	2 studs								
7	4 studs	439	213	137	99	77	62	51	
	2 studs								
8	4 studs	502	243	157	113	88	70	58	
	2 studs								

Result:		L1 [inch]							
Load F [kg]		6	12	18	24	30	36	42	48
3	4 studs	328	328	328	328	328	328	328	328
	2 studs								
4	4 studs	409	409	409	409	409	409	409	409
	2 studs								
5	4 studs	481	481	481	481	481	481	481	481
	2 studs								
6	4 studs	545	545	545	545	545	545	545	545
	2 studs								
7	4 studs	602	602	602	602	602	602	602	602
	2 studs								
8	4 studs	653	653	653	653	653	653	653	653
	2 studs								

NOTE: load capacity used for calculation $N_{rec} = 810 \text{ lb (axial)} / V_{rec} = 618 \text{ lb (shear)}$

FASTENER SYSTEM	FASTENER OVERVIEW	FASTENER TECHNICAL DETAILS	APPLICATION OVERVIEW
HOW TO USE THIS DOCUMENT	DISCLAIMER		

FASTENING T-POST (FLOOR) SUPPORT WITH S-BT HL

Two / Four S-BT-MR HL / S-BT-MF MT HL Threaded studs

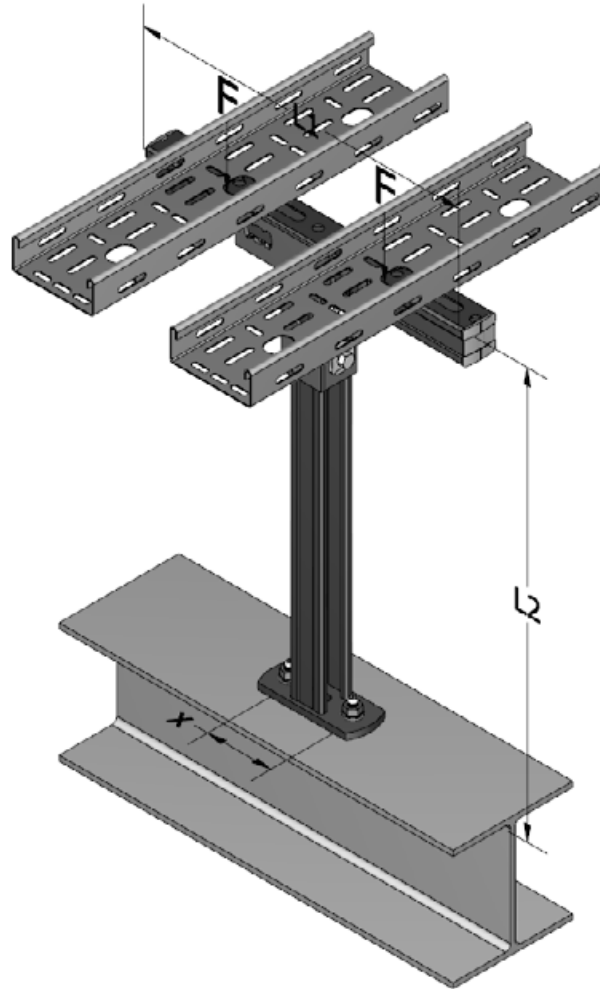

Application

- Fastening of cable trays, pipes on a T-Post support, which is fastened on a horizontal structure
- Support is fastened by two / four S-BT HL (horizontal distance x)
- $L1$ is the total width of the T-Post, $L2$ is fix set to 1000 mm
- Load F is the acceptable total load (all dead load including)

Boundary conditions

- These values are ONLY reflecting capacity of S-BT HL threaded stud. Structural analysis of support / structure is NOT in Hilti scope. See the detailed statements in disclaimer—2018/05/04
- 2 Load cases: load asymmetric acting in the center of one arm only, 30% acting as horizontal load

Technical assessment — maximum of $L1$ and F (depending on load F or lever arm length $L1$ and S-BT HL distance x)

FASTENER SYSTEM

FASTENER OVERVIEW

FASTENER TECHNICAL DETAILS

APPLICATION OVERVIEW

HOW TO USE THIS DOCUMENT

DISCLAIMER

FASTENING T-POST (FLOOR) SUPPORT WITH S-BT HL

Two / Four S-BT-MR HL / S-BT-MF MT HL Threaded studs

2 studs		Result: F [lbs]							Result: L1 [inch]										
x		L1 [inch]	100	150	200	300	400	500	600	700	Load F [lbs]	6	12	18	24	30	36	42	48
x [inch]	3	103	55																
	4	137	73																
	5	172	91	64															
	6	206	109	77	61														
	7	241	127	90	71														
	8	275	145	102	81	68													
	3	205	205	205	205	205	205	205	205	205	205	205	205	205	205	205	205	205	205
	4	274	274	274	274	274	274	274	274	274	274	274	274	274	274	274	274	274	274
5	342	342	342	342	342	342	342	342	342	342	342	342	342	342	342	342	342	342	
6	411	411	411	411	411	411	411	411	411	411	411	411	411	411	411	411	411	411	
7	479	479	479	479	479	479	479	479	479	479	479	479	479	479	479	479	479	479	
8	548	548	548	548	548	548	548	548	548	548	548	548	548	548	548	548	548	548	

4 studs		Result: F [lbs]							Result: Load F [kg]										
x		L1 [mm]	100	150	200	300	400	500	600	700	6	12	18	24	30	36	42	48	
x [inch]	3	200	103																
	4	267	137																
	5	334	172	118															
	6	400	206	141	109														
	7	467	241	165	127														
	8	534	275	189	145	120													
	3	411	411	411	411	411	411	411	411	411	411	411	411	411	411	411	411	411	
	4	548	548	548	548	548	548	548	548	548	548	548	548	548	548	548	548	548	
5	685	685	685	685	685	685	685	685	685	685	685	685	685	685	685	685	685		
6	822	822	822	822	822	822	822	822	822	822	822	822	822	822	822	822	822		
7	959	959	959	959	959	959	959	959	959	959	959	959	959	959	959	959	959		
8	1,096	1,096	1,096	1,096	1,096	1,096	1,096	1,096	1,096	1,096	1,096	1,096	1,096	1,096	1,096	1,096	1,096		

NOTE: load capacity used for calculation $N_{rec} = 810 \text{ lb (axial)} / V_{rec} = 900 \text{ lb (shear)}$

Two / Four S-BT-MF HL Threaded studs

2 studs		Result: F [lbs]							Result: Load F [kg]										
x		L1 [mm]	100	150	200	300	400	500	600	700	6	12	18	24	30	36	42	48	
x [inch]	3	103	55																
	4	137	73																
	5	172	91	64															
	6	206	109	77	61														
	7	241	127	90	71														
	8	275	145	102	81	68													
	3	205	205	205	205	205	205	205	205	205	205	205	205	205	205	205	205	205	
	4	274	274	274	274	274	274	274	274	274	274	274	274	274	274	274	274	274	
5	342	342	342	342	342	342	342	342	342	342	342	342	342	342	342	342	342		
6	411	411	411	411	411	411	411	411	411	411	411	411	411	411	411	411	411		
7	467	467	467	467	467	467	467	467	467	467	467	467	467	467	467	467	467		
8	519	519	519	519	519	519	519	519	519	519	519	519	519	519	519	519	519		

4 studs		Result: F [lbs]							Result: Load F [kg]										
x		L1 [mm]	100	150	200	300	400	500	600	700	6	12	18	24	30	36	42	48	
x [inch]	3	200	103																
	4	267	137																
	5	334	172	118															
	6	400	206	141	109														
	7	467	241	165	127														
	8	534	275	189	145	120													
	→ Load in [kN]		0.49	0.74	0.98	1.23	1.47	1.96	2.45	2.94									
	3	411	411	411	411	411	411	411	411	411	411	411	411	411	411	411	411	411	
4	548	548	548	548	548	548	548	548	548	548	548	548	548	548	548	548	548		
5	685	685	685	685	685	685	685	685	685	685	685	685	685	685	685	685	685		
6	822	822	822	822	822	822	822	822	822	822	822	822	822	822	822	822	822		
7	933	933	933	933	933	933	933	933	933	933	933	933	933	933	933	933	933		
8	1,039	1,039	1,039	1,039	1,039	1,039	1,039	1,039	1,039	1,039	1,039	1,039	1,039	1,039	1,039	1,039	1,039		

NOTE: load capacity used for calculation $N_{rec} = 810 \text{ lb (axial)} / V_{rec} = 618 \text{ lb (shear)}$

FASTENER SYSTEM	FASTENER OVERVIEW	FASTENER TECHNICAL DETAILS	APPLICATION OVERVIEW
HOW TO USE THIS DOCUMENT	DISCLAIMER		

FASTENING U-FRAME (CEILING) / TRAPEZE SUPPORT WITH S-BT HL

Two / Four S-BT-MR HL / S-BT-MF MT HL Threaded studs

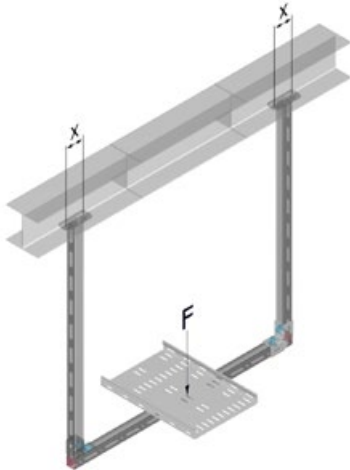

Application

- Fastening of cable trays, pipes on a U-Frame support, which is fastened on a horizontal structure
- Support is fastened by four S-BT HL (2 fasteners per baseplate)
- Load F is the acceptable total load (all dead load including, acting in the center of the U-Frame)

Boundary conditions

- These values are ONLY reflecting capacity of S-BT HL threaded stud. Structural analysis of support / structure is NOT in Hilti scope. See the detailed statements in disclaimer—2018/05/04
- Load acting in the center (U-Frame)

Two / Four S-BT-MR HL / S-BT-MF MT HL / S-BT-MF HL Threaded studs

Technical assessment — maximum of F

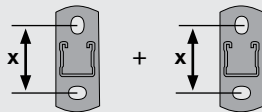
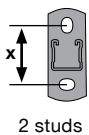

$$F = N_{rec} \cdot \text{\#fasteners per post}$$

$$F = 810 \text{ lb} \cdot 4$$

$$F = 3,240 \text{ lb}$$

NOTE: load capacity used for calculation $N_{rec} = 810 \text{ lb}$ (axial)

FASTENER SYSTEM

FASTENER OVERVIEW

FASTENER TECHNICAL DETAILS

APPLICATION OVERVIEW

HOW TO USE THIS DOCUMENT

DISCLAIMER

FASTENING L-POST SUPPORT WITH S-BT HL

Two / Four S-BT-MR HL / S-BT-MF MT HL Threaded studs

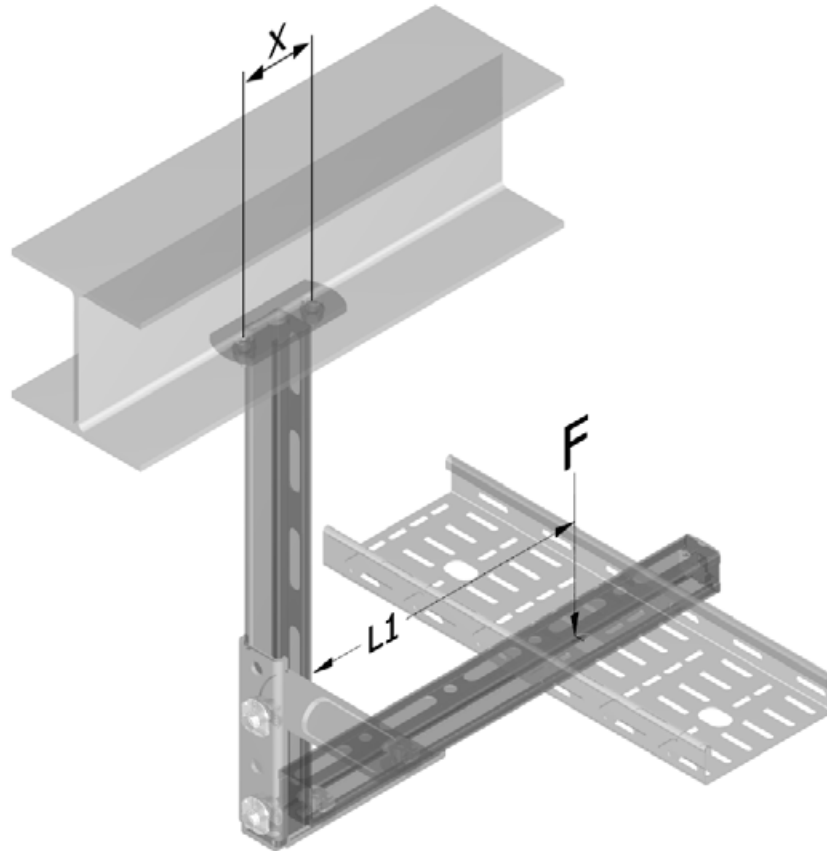

Application

- Fastening of cable trays, pipes on a L-Post support, which is fastened on a horizontal structure
- Support is fastened by two / four S-BT HL (horizontal distance x)
- $L1$ is the distance of the load center to the vertical structure surface
- Load F is the acceptable total load (all dead load including)

Boundary conditions

- These values are ONLY reflecting capacity of S-BT HL threaded stud. Structural analysis of support / structure is NOT in Hilti scope. See the detailed statements in disclaimer—2018/05/04
- Load F acting at the distance of $L1$ from structure surface

Technical assessment – maximum of $L1$ and F (depending on load F or lever arm length $L1$ and S-BT HL distance x)

FASTENER SYSTEM

FASTENER OVERVIEW

FASTENER TECHNICAL DETAILS

APPLICATION OVERVIEW

HOW TO USE THIS DOCUMENT

DISCLAIMER

FASTENING L-POST SUPPORT WITH S-BT HL

Two / Four S-BT-MR HL / S-BT-MF MT HL Threaded studs



2 studs

Result:		F [lbs]							
L1 [inch]		100	150	200	300	400	500	600	700
3	x	411	411	411	411	411	411	411	411
	[inch]	548	548	548	548	548	548	548	548
4	x	685	685	685	685	685	685	685	685
	[inch]	822	822	822	822	822	822	822	822
5	x	959	959	959	959	959	959	959	959
	[inch]	1,096	1,096	1,096	1,096	1,096	1,096	1,096	1,096

Result:		L1 [inch]							
Load F [lbs]		6	12	18	24	30	36	42	48
3	x	323	180	124	95	77	65	56	49
	[mm]	404	231	162	124	101	85	73	65
4	x	476	279	197	153	124	105	91	80
	[mm]	539	323	231	180	147	124	108	95
5	x	596	365	263	206	169	143	124	110
	[mm]	647	404	294	231	190	162	141	124



4 studs

Result:		F [lbs]							
L1 [mm]		100	150	200	300	400	500	600	700
3	x	47	23	15	11	8	7	5	5
	[inch]	63	30	20	14	11	9	7	6
4	x	78	38	24	18	14	11	9	8
	[inch]	94	46	29	21	16	13	11	9
5	x	110	53	34	25	19	15	13	11
	[inch]	125	61	39	28	22	18	14	12

Result:		L1 [inch]							
Load F [kg]		6	12	18	24	30	36	42	48
3	x	647	359	249	190	154	129	112	98
	[mm]	809	462	323	249	202	170	147	129
4	x	952	558	395	305	249	210	182	160
	[mm]	1,079	647	462	359	294	249	216	190
5	x	1,192	731	527	412	338	287	249	220
	[mm]	1,294	809	588	462	381	323	281	249

NOTE: load capacity used for calculation $N_{rec} = 810 \text{ lb (axial)} / V_{rec} = 900 \text{ lb (shear)}$

Two / Four S-BT-MF HL Threaded studs



2 studs

Result:		F [lbs]							
L1 [mm]		100	150	200	300	400	500	600	700
3	x	23	11	7	5	3	3	2	2
	[inch]	30	14	9	6	4	3	3	2
4	x	38	18	11	8	6	4	3	3
	[inch]	46	21	13	9	7	5	4	3
5	x	53	25	15	11	8	6	5	4
	[inch]	61	28	18	12	9	7	5	4

Result:		L1 [inch]							
Load F [kg]		6	12	18	24	30	36	42	48
3	x	323	180	124	95	77	65	56	49
	[mm]	404	231	162	124	101	85	73	65
4	x	476	279	197	153	124	105	91	80
	[mm]	539	323	231	180	147	124	108	95
5	x	596	365	263	206	169	143	124	110
	[mm]	647	404	294	231	190	162	141	124



4 studs

Result:		F [lbs]							
L1 [mm]		100	150	200	300	400	500	600	700
→ Load in [kN]		0.49	0.74	0.98	1.23	1.47	1.96	2.45	2.94
3	x	47	23	15	11	8	7	5	5
	[inch]	63	30	20	14	11	9	7	6
4	x	78	38	24	18	14	11	9	8
	[inch]	94	46	29	21	16	13	11	9
5	x	110	53	34	25	19	15	13	11
	[inch]	125	61	39	28	22	18	14	12

Result:		L1 [inch]							
Load F [kg]		6	12	18	24	30	36	42	48
3	x	647	359	249	190	154	129	112	98
	[mm]	809	462	323	249	202	170	147	129
4	x	952	558	395	305	249	210	182	160
	[mm]	1,079	647	462	359	294	249	216	190
5	x	1,192	731	527	412	338	287	249	220
	[mm]	1,294	809	588	462	381	323	281	249

NOTE: load capacity used for calculation $N_{rec} = 810 \text{ lb (axial)} / V_{rec} = 618 \text{ lb (shear)}$

[FASTENER SYSTEM](#)
[FASTENER OVERVIEW](#)
[FASTENER TECHNICAL DETAILS](#)
[APPLICATION OVERVIEW](#)
[HOW TO USE THIS DOCUMENT](#)
[DISCLAIMER](#)

FASTENING EQUIPMENT SUPPORT WITH S-BT HL

Two / Four S-BT-MR HL / S-BT-MF MT HL Threaded studs

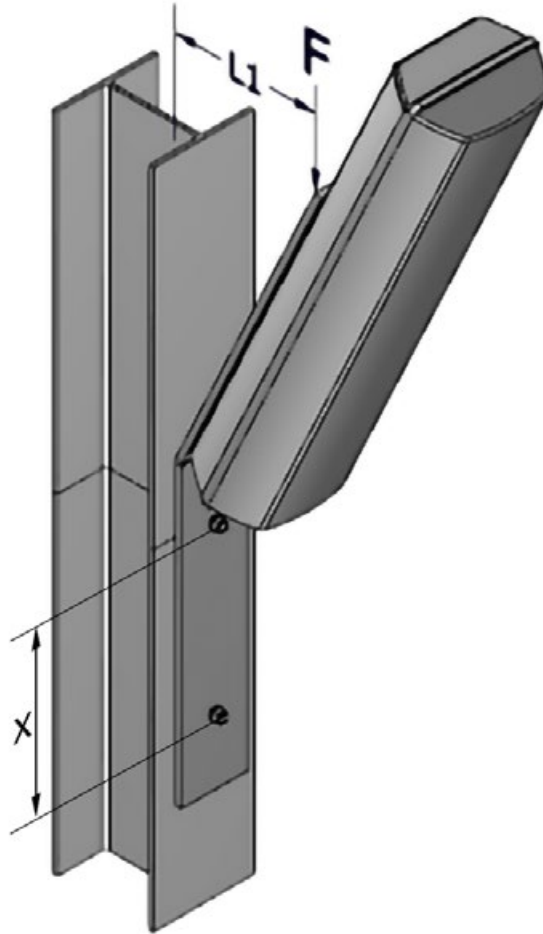

Application

- Fastening of lamps, signals, sensors on inclined cantilever support, fastened on a vertical structure
- Support is fastened by two / four S-BT HL (vertical distance x)
- $L1$ is the distance of the load center (~middle of the load) to the vertical structure surface
- Load F is the acceptable total load (all dead load including)

Boundary conditions

- These values are ONLY reflecting capacity of S-BT HL threaded stud. Structural analysis of support / structure is NOT in Hilti scope. See the detailed statements in disclaimer—2018/05/04
- Shear load fully carried by one / two top S-BT HL (worst-case)
- Load F acting at the distance of $L1$ from structure surface

Technical assessment – maximum of $L1$ and F (depending on load F or lever arm length $L1$ and S-BT HL distance x)

FASTENER SYSTEM	FASTENER OVERVIEW	FASTENER TECHNICAL DETAILS	APPLICATION OVERVIEW
HOW TO USE THIS DOCUMENT	DISCLAIMER		

FASTENING EQUIPMENT SUPPORT WITH S-BT HL

Two / Four S-BT-MR HL / S-BT-MF MT HL Threaded studs

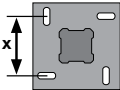
 2 studs		Result:		F [lbs]							Result: Load F [lbs]		L1 [inch]							
		L1 [inch]		100	150	200	300	400	500	600			700	6	12	18	24	30	36	42
 4 studs	x [inch]	3		24	12	7	5	3	2	1	1	3	335	198	135	101	81	67	58	50
		4		32	16	9	6	4	3	2	1	4	404	249	180	135	108	90	77	67
		5		40	20	12	8	5	4	2	2	5	462	294	216	168	135	112	96	84
		6		49	24	14	9	6	4	3	2	6	511	335	249	198	162	135	116	101
		7		57	28	16	11	7	5	3	2	7	552	371	280	224	187	157	135	118
		8		65	32	19	12	8	6	4	3	8	588	404	308	249	209	180	154	135
		3		49	24	16	12	9	7	6	5	3	670	396	270	202	162	135	116	101
		4		65	32	22	16	12	9	7	6	4	809	498	359	270	216	180	154	135
5		81	40	27	20	15	12	9	8	5	924	588	431	337	270	225	192	168		
6		97	49	32	24	18	14	11	9	6	1,022	670	498	396	323	270	231	202		
7		113	57	38	28	21	16	13	11	7	1,105	743	559	448	374	315	270	236		
8		129	65	43	32	24	19	15	12	8	1,177	809	616	498	418	359	308	270		

NOTE: load capacity used for calculation $N_{rec} = 810 \text{ lb (axial)} / V_{rec} = 900 \text{ lb (shear)}$

Two / Four S-BT-MF HL Threaded studs

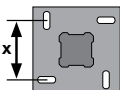
 2 studs		Result:		F [lbs]							Result: Load F [kg]		L1 [inch]							
		L1 [mm]		100	150	200	300	400	500	600			700	6	12	18	24	30	36	42
 4 studs	x [inch]	3		24	11	6	3	2	1		3	293	183	133	101	81	67	58	50	
		4		32	14	8	4	3	1		4	345	225	167	133	108	90	77	67	
		5		40	18	10	6	3	2		5	387	262	198	159	133	112	96	84	
		6		49	21	12	7	4	2		6	420	293	225	183	154	133	116	101	
		7		57	25	13	8	4	2		7	448	321	250	205	174	150	133	118	
		8		65	28	15	9	5	2		8	471	345	273	225	192	167	148	133	
		3		49	24	15	11	8	6	4	3	3	587	366	265	202	162	135	116	101
		4		65	32	21	14	10	8	6	4	4	691	450	334	265	216	180	154	135
5		81	40	26	18	13	10	7	6	5	774	523	396	318	265	225	192	168		
6		97	49	31	21	15	12	9	7	6	841	587	450	366	308	265	231	202		
7		113	57	36	25	18	13	10	8	7	896	642	500	410	347	301	265	236		
8		129	65	41	28	21	15	12	9	8	943	691	545	450	384	334	296	265		

NOTE: load capacity used for calculation $N_{rec} = 810 \text{ lb (axial)} / V_{rec} = 618 \text{ lb (shear)}$

FASTENER SYSTEM	FASTENER OVERVIEW	FASTENER TECHNICAL DETAILS	APPLICATION OVERVIEW
HOW TO USE THIS DOCUMENT	DISCLAIMER		

FASTENING JUNCTION BOXES / SWITCHES WITH S-BT HL

S-BT-MR HL / S-BT-MF MT HL Threaded stud

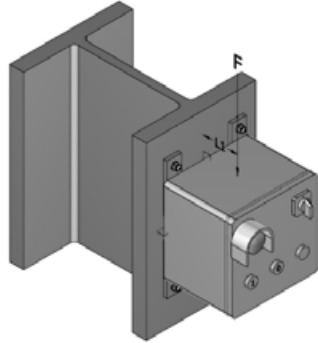

Application

- Fastening of junction boxes, switches on a vertical structure
- Element is fastened by S-BT HL

Boundary conditions

- These values are ONLY reflecting capacity of S-BT HL threaded stud. Structural analysis of support / structure is NOT in Hilti scope. See the detailed statements in disclaimer—2018/05/04
- Technical data are based on Product Data Sheet for S-BT HL (12/2022), always refer to latest Product Data Sheet for S-BT HL

Technical data — always refer to latest technical data binder for S-BT HL

Recommended load	S-BT-MR HL		S-BT-MF MT HL		S-BT-MF HL	
Drill hole type and base material thickness			Pilot hole, $t_{II} \geq 0.24"$ Drill through hole, $0.20" \leq t_{II} < 0.24"$			
Base material	Steel S235	Steel S355	Steel S235	Steel S355	Steel S235	Steel S355
Tension, N_{rec} [lb]	810	970	900	1080	900	1080
Shear, V_{rec} [lb]	920	920	900	900	625	625
Moment, M_{rec} [ft-lb]	8.0	8.0	5.0	5.0	5.0	5.0

Design resistance	S-BT-MR HL		S-BT-MF MT HL		S-BT-MF HL	
Drill hole type and base material thickness			Pilot hole, $t_{II} \geq 0.24"$ Drill through hole, $0.20" \leq t_{II} < 0.24"$			
Base material	Steel S235	Steel S355	Steel S235	Steel S355	Steel S235	Steel S355
Tension, N_{Rec} [lb]	1145	1370	1280	1525	1280	1525
Shear, V_{Rec} [lb]	1280	1280	1255	1255	875	875
Moment, M_{Rec} [ft-lb]	12.0	12.0	7.0	7.0	7.0	7.0

Conditions for recommended loads and design loads

- Use S-BT-MR HL and S-BT-MF (MT) HL (multipurpose fastening) only with the supplied Hilti serrated flange nuts M8, M10, W10 (⊕ or ⊗) as per according to General Information—Material specifications)
- Global factor of safety Ω resp. partial factor of safety γ_m (based on 5% fractile ultimate test value)

Safety Factors

	Recommended Loads	Design loads
Static pull-out	2.80	2.00
Static shear	2.80	2.00
Bending	1.75	1.25

- Minimum edge distance = 6 mm (0.24"), minimum spacing ≥ 18 mm (0.709")
- Effect of base metal vibration and stress (e.g. areas with tensile stress) considered.
- Redundancy (multiple fastening) must be provided.
- If eccentric loading exists (e.g. use of an angle clip), moments caused by off-center loading must be considered.

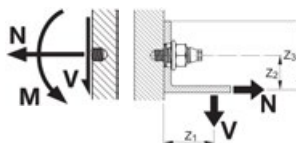

Recommended interaction formula for combined loading — steel and aluminum base material

$$V-N \text{ (shear and tension)} \quad \frac{V}{V_{rec}} + \frac{N}{N_{rec}} \leq 1.0 \text{ with } \frac{V}{V_{rec}} \leq 1.0 \text{ and } \frac{N}{N_{rec}} \leq 1.0$$

$$V-M \text{ (shear and bending)} \quad \frac{V}{V_{rec}} + \frac{M}{M_{rec}} \leq 1.0 \text{ with } \frac{V}{V_{rec}} \leq 1.0 \text{ and } \frac{M}{M_{rec}} \leq 1.0$$

$$N-M \text{ (tension and bending)} \quad \frac{N}{N_{rec}} + \frac{M}{M_{rec}} \leq 1.0$$

$$V-N-M \text{ (shear, tension and bending)} \quad \frac{V}{V_{rec}} + \frac{N}{N_{rec}} + \frac{M}{M_{rec}} \leq 1.0$$

Cyclic loading

S-BT HL threaded studs are only to be used for fastenings subject to static or quasi-static loading. Inquire at Hilti for test data if cyclic loading has to be considered in the design.

S-BT HL CATALOG PAGES

Description	Base Material	Environment	Item Number
Threaded stud S-BT-MF M8/7 AN 6 HL	Steel	Mildly corrosive	2345768
Threaded stud S-BT-MF M8/15 AN 6 HL	Steel	Mildly corrosive	2345769
Threaded stud S-BT-MF M10/15 AN 6 HL	Steel	Mildly corrosive	2346060
Threaded stud S-BT-MF W10/15 AN 6 HL	Steel	Mildly corrosive	2346061
Threaded stud S-BT-MF MT M10/15 AN 6 HL	Steel	Mildly corrosive	2350549
Threaded stud S-BT-MF MT W10/15 AN 6 HL	Steel	Mildly corrosive	2350880
Threaded stud S-BT-MR M8/7 SN 6 HL	Steel	Highly corrosive	2346062
Threaded stud S-BT-MR M8/15 SN 6 HL	Steel	Highly corrosive	2346063
Threaded stud S-BT-MR M10/15 SN 6 HL	Steel	Highly corrosive	2346064
Threaded stud S-BT-MR W10/15 SN 6 HL	Steel	Highly corrosive	2346065



Description	Item Number
Stepped drill bit TS-BT 5.3-65 S	2346083
Stud holder S-SH BT M8	2361441
Stud holder S-SH BT M10/W10	2361442
Nut setter S-NS 13 C 95/3 1/4"	2149244
Nut setter S-NS 15 C 95/3 1/4"	2149245
Nut setter S-NS 9/16" C 95/3 3/4"	2149246
Depth gauge S-DG BT M8/7 Short 6	2279735
Depth gauge S-DG BT M8/15 Long 6	2148575
Depth gauge S-DG BT M10-W10/15 Long 6	2143261
Check gauge S-CG BT /7 Short 6	2143262
Check gauge S-CG BT /15 long 6	2143263
Inspection card S-IC BT	2383883
Calibration card S-CC BT 6	2143270
Torque tool S-BT 1/4" — 16 Nm / 11.8 lbf-ft	2346085
SBT 4-A22	Refer to Hilti Online
SBT 6-22	Refer to Hilti Online







X-ST-GR THREADED STUD

Imperial



X-ST-GR TECHNICAL DATA USED FOR THE FOLLOWING CALCULATIONS

X-ST-GR technical data

- **Drill hole type / base material:** no predrilling, $t_{II} \geq 6 \text{ mm}$ (0.24")
- **Base material:** Steel S235 / A36 (higher steel strength is possible, see application limit)
- **Recommended interaction for combined load:** $N_{rec} = 405 \text{ lb}$ (axial) / $V_{rec} = 405 \text{ lb}$ (shear)

V-N (shear and tension)

$$\frac{V}{V_{rec}} + \frac{N}{N_{rec}} \leq 1.2 \quad \text{with} \quad \frac{V}{V_{rec}} \leq 1.0 \quad \text{and} \quad \frac{N}{N_{rec}} \leq 1.0$$

Application limit

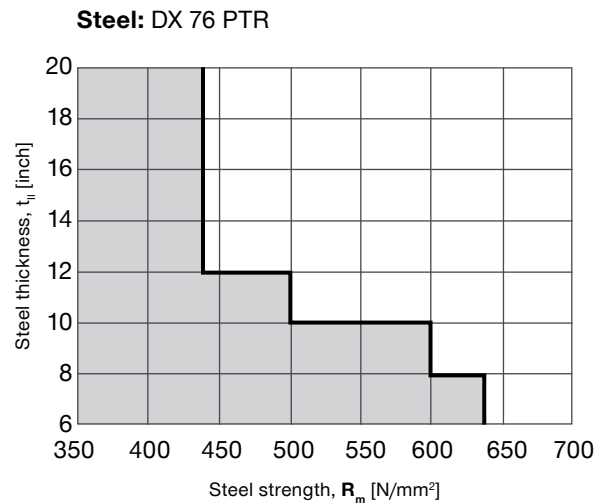
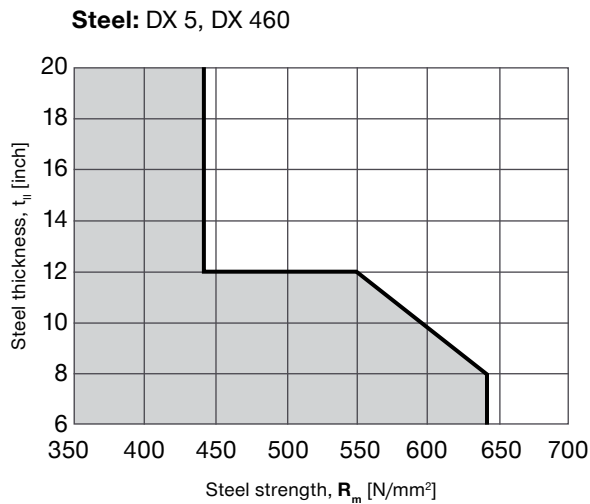

For further technical data refer to the latest technical information (DFTM / binder)

FASTENING CANTILEVER SUPPORT WITH X-ST-GR

Two / Four X-ST-GR Threaded studs

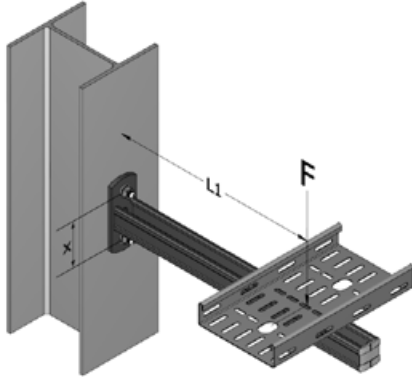

Application

- Fastening of cable trays, pipes on a horizontal cantilever support, fastened on a vertical structure
- Support is fastened by two / four X-ST-GR on both support and brace baseplate with distance x
- L1 is the distance of the load center to the vertical structure surface
- Load F is the acceptable total load (all dead load including)

Boundary conditions

- These values are ONLY reflecting capacity of X-ST-GR threaded stud. Structural analysis of support / structure is NOT in Hilti scope. See the detailed statements in disclaimer—2018/05/04
- Shear load fully carried by one / two top X-ST-GR (worst-case)
- Load F acting at the distance of L1 from structure surface

Technical assessment – maximum of L1 and F (depending on load F or lever arm length L1 and X-ST-GR distance x)

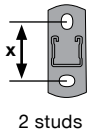

Result: L1 [inch]	F [lbs]							
	100	150	200	300	400	500	600	700
x [inch]	3.0	9.25	5.00	3.00	1.00			
	4.0	12.25	6.75	4.00	1.50			
	5.0	15.25	8.50	5.00	1.75			
	6.0	18.25	10.25	6.25	2.00			
	7.0	21.25	12.00	7.25	2.50			
	8.0	24.25	13.50	8.25	2.75			

Result: Load F [lbs]	L1 [inch]							
	6.0	12.0	18.0	24.0	30.0	36.0	42.0	48.0
x [inch]	3.0	135	81	58	45	37	31	27
	4.0	162	101	73	58	47	40	35
	5.0	184	119	88	70	58	49	43
	6.0	202	135	101	81	67	58	50
	7.0	218	149	113	91	77	66	58
	8.0	231	162	124	101	85	73	65

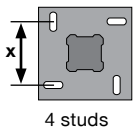

Result: L1 [inch]	F [lbs]							
	100	150	200	300	400	500	600	700
x [inch]	3.0	21.25	13.00	9.00	5.00	3.00	1.75	1.00
	4.0	28.25	17.50	12.00	6.75	4.00	2.25	1.25
	5.0	35.25	21.75	15.00	8.25	5.00	3.00	1.50
	6.0	42.50	26.25	18.25	10.00	6.00	3.50	2.00
	7.0	49.50	30.75	21.25	11.75	7.00	4.25	2.25
	8.0	56.50	35.00	24.25	13.50	8.00	4.75	2.75

Result: Load F [lbs]	L1 [inch]							
	6.0	12.0	18.0	24.0	30.0	36.0	42.0	48.0
x [inch]	3.0	270	162	116	90	73	62	54
	4.0	323	202	147	116	95	81	70
	5.0	368	238	176	139	116	99	86
	6.0	404	270	202	162	135	116	101
	7.0	436	298	226	183	153	132	116
	8.0	462	323	249	202	170	147	129

NOTE: load capacity used for calculation $N_{rec} = 405 \text{ lb (axial)} / V_{rec} = 405 \text{ lb (shear)}$

[FASTENER SYSTEM](#)
[FASTENER OVERVIEW](#)
[FASTENER TECHNICAL DETAILS](#)
[APPLICATION OVERVIEW](#)
[HOW TO USE THIS DOCUMENT](#)
[DISCLAIMER](#)

FASTENING BRACED CANTILEVER SUPPORT WITH X-ST-GR

Two / Four X-ST-GR Threaded studs

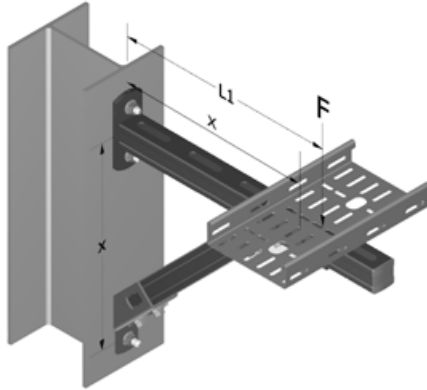

Application

- Fastening of cable trays, pipes on a horizontal, braced cantilever support, fastened on a vertical structure
- Support is fastened by three / six X-ST-GR on both support and brace baseplate with distance x
- L1 is the distance of the load center to the vertical structure surface, the angle of the brace is 45°
- Load F is the acceptable total load (all dead load including)

Boundary conditions

- These values are ONLY reflecting capacity of X-ST-GR threaded stud. Structural analysis of support / structure is NOT in Hilti scope. See the detailed statements in disclaimer—2018/05/04
- Shear load fully carried by one / two top X-ST-GR (worst-case)
- Load F acting at the distance of L1 from structure surface

Technical assessment — maximum of F (depending on load F or lever arm length L1 and baseplate distance x)



Result: L1 [inch]	F [lbs]							
	100	150	200	300	400	500	600	700
x [inch]	4.0	13.25	9.75	8.00	5.25	4.00		
	6.0	20.00	14.75	12.00	8.00	6.00		
	8.0	26.75	19.50	16.00	10.75	8.00		
	14.0	47.00	34.50	28.00	18.75	14.00		
	20.0	67.25	49.25	40.25	26.75	20.00		
	32.0	107.50	78.75	64.25	43.00	32.25		

Result: Load F [lbs]	L1 [inch]							
	6.0	12.0	18.0	24.0	30.0	36.0	42.0	48.0
x [inch]	4.0	270	135	90	67			
	6.0	404	202	135	101			
	8.0		270	180	135			
	14.0			315	236			
	20.0				337			
	32.0							

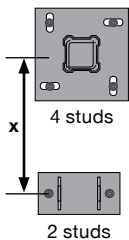

Result: L1 [inch]	F [lbs]								
	100	150	200	300	400	500	600	700	
x [inch]	4.0	24.00	17.00	13.25	9.75	8.00	6.25	5.25	4.50
	6.0	36.25	25.50	20.00	14.75	12.00	9.50	8.00	6.75
	8.0	48.25	34.00	26.75	19.50	16.00	12.75	10.75	9.00
	14.0	84.75	59.50	47.00	34.50	28.00	22.50	18.75	16.00
	20.0	121.00	85.25	67.25	49.25	40.25	32.25	26.75	23.00
	32.0	193.75	136.25	107.50	78.75	64.25	51.75	43.00	36.75

Result: Load F [lbs]	L1 [inch]								
	6.0	12.0	18.0	24.0	30.0	36.0	42.0	48.0	
x [inch]	4.0	539	270	180	135				
	6.0	809	404	270	202	162	135		
	8.0		539	359	270	216	180	154	135
	14.0			629	472	377	315	270	236
	20.0				674	539	449	385	337
	32.0						719	616	539

NOTE: load capacity used for calculation $N_{rec} = 405 \text{ lb (axial)} / V_{rec} = 405 \text{ lb (shear)}$

[FASTENER SYSTEM](#)
[FASTENER OVERVIEW](#)
[FASTENER TECHNICAL DETAILS](#)
[APPLICATION OVERVIEW](#)
[HOW TO USE THIS DOCUMENT](#)
[DISCLAIMER](#)

FASTENING STRUT TO STEEL WITH X-ST-GR

Two X-ST-GR Threaded studs

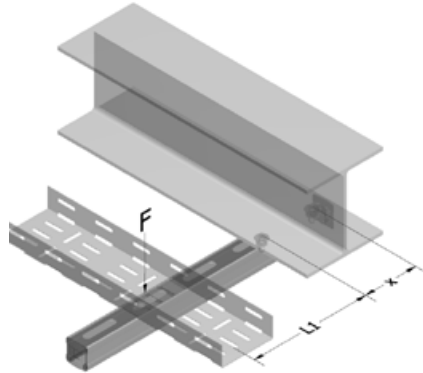

Application

- Fastening of cable trays, pipes on a horizontal cantilever support, fastened on a horizontal structure
- Support is fastened by two X-ST-GR (horizontal distance x)
- L1 is the distance of the load center to the vertical structure surface
- Load F is the acceptable total load (all dead load including)

Boundary conditions

- These values are ONLY reflecting capacity of X-ST-GR threaded stud. Structural analysis of support / structure is NOT in Hilti scope. See the detailed statements in disclaimer—2018/05/04
- Load F acting at the distance of L1 from structure surface

Technical assessment – maximum of L1 and F (depending on load F or lever arm length L1 and X-ST-GR distance x)

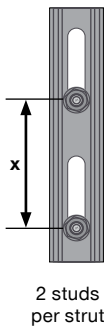

Result: L1 [inch]	F [lbs]							
	100	150	200	300	400	500	600	700
3.0	9.00	5.00	3.00	1.00				
4.0	12.00	6.75	4.00	1.25				
5.0	15.00	8.25	5.00	1.50				
6.0	18.25	10.00	6.00	2.00				
7.0	21.25	11.75	7.00	2.25				
8.0	24.25	13.50	8.00	2.75				

Result: Load F [lbs]	L1 [inch]							
	6.0	12.0	18.0	24.0	30.0	36.0	42.0	48.0
3.0	135	81	58	45	37	31	27	24
4.0	162	101	73	58	47	40	35	31
5.0	184	119	88	70	58	49	43	38
6.0	202	135	101	81	67	58	50	45
7.0	218	149	113	91	77	66	58	51
8.0	231	162	124	101	85	73	65	58

NOTE: load capacity used for calculation $N_{rec} = 405 \text{ lb (axial)} / V_{rec} = 405 \text{ lb (shear)}$

FASTENER SYSTEM	FASTENER OVERVIEW	FASTENER TECHNICAL DETAILS	APPLICATION OVERVIEW
HOW TO USE THIS DOCUMENT	DISCLAIMER		

FASTENING STRUT TO STEEL WITH X-ST-GR

Two / Four X-ST-GR Threaded studs

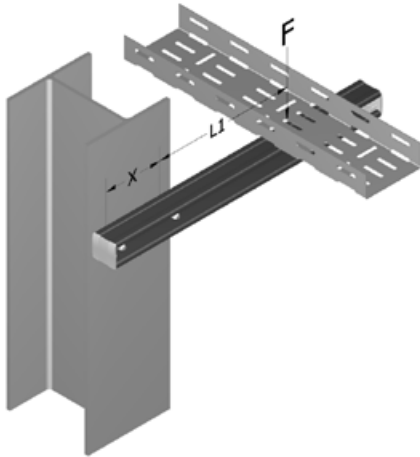

Application

- Fastening of cable trays, pipes on a horizontal cantilever support, fastened on a vertical structure
- Support is fastened by two X-ST-GR (horizontal distance x)
- L1 is the distance of the load center to the center of the fasteners
- Load F is the acceptable total load (all dead load including)

Boundary conditions

- These values are ONLY reflecting capacity of X-ST-GR threaded stud. Structural analysis of support / structure is NOT in Hilti scope. See the detailed statements in disclaimer—2018/05/04
- Shear load fully carried by one X-ST-GR (worst-case)
- Load F acting at the distance of L1 from structure surface

Technical assessment – maximum of L1 and F (depending on load F or lever arm length L1 and X-ST-GR distance x)

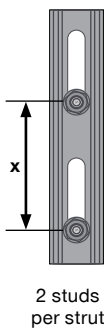

Result: L1 [inch]		F [lbs]							
		100	150	200	300	400	500	600	700
x [inch]	3.0	9.00	5.00	3.00	1.00				
	4.0	12.00	6.75	4.00	1.25				
	5.0	15.00	8.25	5.00	1.50				
	6.0	18.25	10.00	6.00	2.00				
	7.0	21.25	11.75	7.00	2.25				
	8.0	24.25	13.50	8.00	2.75				

Result: Load F [lbs]		L1 [inch]							
		6.0	12.0	18.0	24.0	30.0	36.0	42.0	48.0
x [inch]	3.0	135	81	58	45	37	31	27	24
	4.0	162	101	73	58	47	40	35	31
	5.0	184	119	88	70	58	49	43	38
	6.0	202	135	101	81	67	58	50	45
	7.0	218	149	113	91	77	66	58	51
	8.0	231	162	124	101	85	73	65	58

NOTE: load capacity used for calculation $N_{rec} = 405 \text{ lb (axial)} / V_{rec} = 405 \text{ lb (shear)}$

FASTENER SYSTEM	FASTENER OVERVIEW	FASTENER TECHNICAL DETAILS	APPLICATION OVERVIEW
HOW TO USE THIS DOCUMENT	DISCLAIMER		

FASTENING T-POST (CEILING) SUPPORT WITH X-ST-GR

Two / Four X-ST-GR Threaded studs

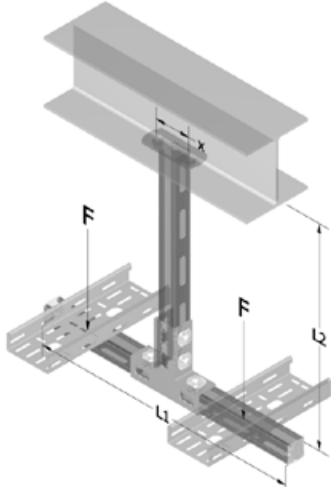

Application

- Fastening of cable trays, pipes on a T-Post support, which is fastened on a horizontal structure
- Support is fastened by two / four X-ST-GR (horizontal distance x)
- L1 is the total width of the T-Post, L2 is fix set to 1000 mm
- Load F is the acceptable total load (all dead load including)

Boundary conditions

- These values are ONLY reflecting capacity of X-ST-GR threaded stud. Structural analysis of support / structure is NOT in Hilti scope. See the detailed statements in disclaimer—2018/05/04
- 2 Load cases: load asymmetric acting in the center of one arm only, 30% acting as horizontal load

Technical assessment – maximum of L1 and F (depending on load F or lever arm length L1 and X-ST-GR distance x)

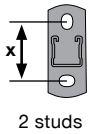

Result: L1 [inch]	F [lbs]							
	100	150	200	300	400	500	600	700
x [inch]	3.0							
	4.0	56.50						
	5.0	70.75						
	6.0	85.00						
	7.0	99.25	61.50					
	8.0	113.25	70.25					

Result: Load F [lbs]	L1 [inch]							
	6.0	12.0	18.0	24.0	30.0	36.0	42.0	48.0
x [inch]	3.0	85	85	85	85	85	85	85
	4.0	108	108	108	108	108	108	108
	5.0	128	128	128	128	128	128	128
	6.0	146	146	146	146	146	146	146
	7.0	162	162	162	162	162	162	162
	8.0	178	178	178	178	178	178	178

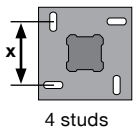

Result: L1 [inch]	F [lbs]							
	100	150	200	300	400	500	600	700
x [inch]	3.0	91.00	58.50					
	4.0	121.25	78.25	56.50				
	5.0	151.75	97.75	70.75				
	6.0	182.00	117.25	85.00				
	7.0	212.50	137.00	99.25	61.50			
	8.0	242.75	156.50	113.25	70.25			

Result: Load F [lbs]	L1 [inch]							
	6.0	12.0	18.0	24.0	30.0	36.0	42.0	48.0
x [inch]	3.0	154	154	154	154	154	154	154
	4.0	190	190	190	190	190	190	190
	5.0	221	221	221	221	221	221	221
	6.0	247	247	247	247	247	247	247
	7.0	271	271	271	271	271	271	271
	8.0	291	291	291	291	291	291	291

NOTE: load capacity used for calculation $N_{rec} = 405 \text{ lb (axial)} / V_{rec} = 405 \text{ lb (shear)}$

[FASTENER SYSTEM](#)

[FASTENER OVERVIEW](#)

[FASTENER TECHNICAL DETAILS](#)

[APPLICATION OVERVIEW](#)

[HOW TO USE THIS DOCUMENT](#)

[DISCLAIMER](#)

FASTENING T-POST (FLOOR) SUPPORT WITH X-ST-GR

Two / Four X-ST-GR Threaded studs

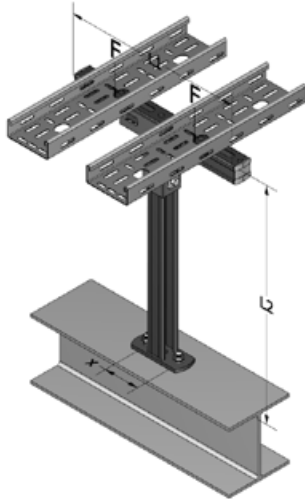

Application

- Fastening of cable trays, pipes on a T-Post support, which is fastened on a horizontal structure
- Support is fastened by two / four X-ST-GR (horizontal distance x)
- L1 is the total width of the T-Post, L2 is fix set to 1000 mm
- Load F is the acceptable total load (all dead load including)

Boundary conditions

- These values are ONLY reflecting capacity of X-ST-GR threaded stud. Structural analysis of support / structure is NOT in Hilti scope. See the detailed statements in disclaimer—2018/05/04
- 2 Load cases: load asymmetric acting in the center of one arm only, 30% acting as horizontal load

Technical assessment – maximum of L1 and F (depending on load F or lever arm length L1 and X-ST-GR distance x)

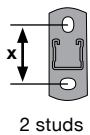

2 studs

Result: L1 [inch]	F [lbs]							
	100	150	200	300	400	500	600	700
x [inch]	3.0							
	4.0	72.50						
	5.0	90.75	63.75					
	6.0	109.00	76.50					
	7.0	127.25	89.50	70.50				
	8.0	145.25	102.25	80.50				

Result: Load F [lbs]	L1 [inch]							
	6.0	12.0	18.0	24.0	30.0	36.0	42.0	48.0
x [inch]	3.0	95	95	95	95	95	95	95
	4.0	124	124	124	124	124	124	124
	5.0	152	152	152	152	152	152	152
	6.0	178	178	178	178	178	178	178
	7.0	203	203	203	203	203	203	203
	8.0	228	228	228	228	228	228	228

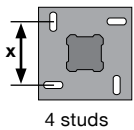

4 studs

Result: L1 [inch]	F [lbs]							
	100	150	200	300	400	500	600	700
x [inch]	3.0							
	4.0	137.25						
	5.0	171.75	117.75					
	6.0	206.00	141.25					
	7.0	240.50	165.00	127.25				
	8.0	274.75	188.50	145.25				

Result: Load F [lbs]	L1 [inch]							
	6.0	12.0	18.0	24.0	30.0	36.0	42.0	48.0
x [inch]	3.0	191	191	191	191	191	191	191
	4.0	249	249	249	249	249	249	249
	5.0	304	304	304	304	304	304	304
	6.0	356	356	356	356	356	356	356
	7.0	407	407	407	407	407	407	407
	8.0	455	455	455	455	455	455	455

NOTE: load capacity used for calculation $N_{rec} = 405 \text{ lb (axial)} / V_{rec} = 405 \text{ lb (shear)}$

[FASTENER SYSTEM](#)
[FASTENER OVERVIEW](#)
[FASTENER TECHNICAL DETAILS](#)
[APPLICATION OVERVIEW](#)
[HOW TO USE THIS DOCUMENT](#)
[DISCLAIMER](#)

FASTENING U-FRAME (CEILING) / TRAPEZE SUPPORT WITH X-ST-GR

Two / Four X-ST-GR Threaded studs

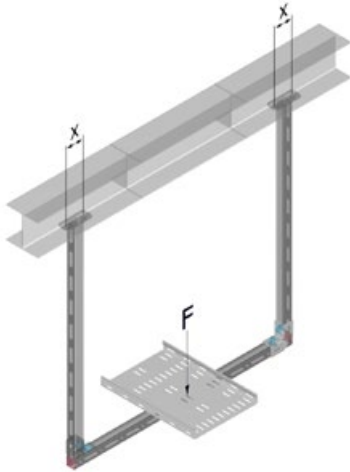

Application

- Fastening of cable trays, pipes on a U-Frame support, which is fastened on a horizontal structure
- Support is fastened by four X-ST-GR (2 fasteners per baseplate)
- Load F is the acceptable total load (all dead load including, acting in the center of the U-Frame)

Boundary conditions

- These values are ONLY reflecting capacity of X-ST-GR threaded stud. Structural analysis of support / structure is NOT in Hilti scope. See the detailed statements in disclaimer—2018/05/04
- Load acting in the center (U-Frame)

Technical assessment — maximum of F

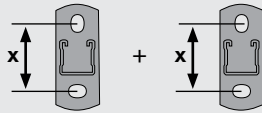
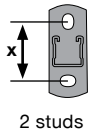

$$F = N_{rec} \cdot \text{\#fasteners per post}$$

$$F = 405 \text{ lb} \cdot 4$$

$$F = 1,620 \text{ lb}$$

NOTE: load capacity used for calculation $N_{rec} = 405 \text{ lb (axial)} / V_{rec} = 405 \text{ lb (shear)}$

FASTENER SYSTEM

FASTENER OVERVIEW

FASTENER TECHNICAL DETAILS

APPLICATION OVERVIEW

HOW TO USE THIS DOCUMENT

DISCLAIMER

FASTENING L-POST SUPPORT WITH X-ST-GR

Two / Four X-ST-GR Threaded studs

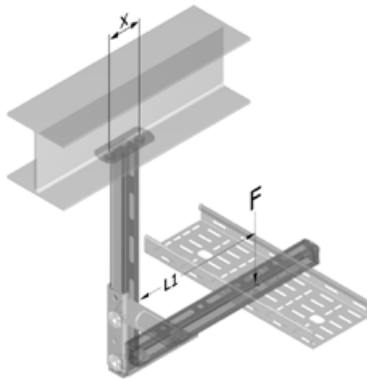

Application

- Fastening of cable trays, pipes on a L-Post support, which is fastened on a horizontal structure
- Support is fastened by two / four X-ST-GR (horizontal distance x)
- L1 is the distance of the load center to the vertical structure surface
- Load F is the acceptable total load (all dead load including)

Boundary conditions

- These values are ONLY reflecting capacity of X-ST-GR threaded stud. Structural analysis of support / structure is NOT in Hilti scope. See the detailed statements in disclaimer—2018/05/04
- Load F acting at the distance of L1 from structure surface

Technical assessment – maximum of L1 and F (depending on load F or lever arm length L1 and X-ST-GR distance x)

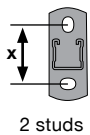

Result: L1 [inch]	F [lbs]							
	100	150	200	300	400	500	600	700
x [inch]	3.0	10.50	6.50	4.50	2.50	1.50	0.75	0.50
	4.0	14.00	8.75	6.00	3.25	2.00	1.00	0.25
	5.0	17.50	10.75	7.50	4.00	2.50	1.50	0.75
	6.0	21.25	13.00	9.00	5.00	3.00	1.75	1.00
	7.0	24.75	15.25	10.50	5.75	3.50	2.00	1.00
	8.0	28.25	17.50	12.00	6.75	4.00	2.25	1.25

Result: Load F [lbs]	L1 [inch]							
	6.0	12.0	18.0	24.0	30.0	36.0	42.0	48.0
x [inch]	3.0	162	90	62	47	38	32	24
	4.0	202	116	81	62	50	43	32
	5.0	238	139	99	76	62	52	40
	6.0	270	162	116	90	73	62	54
	7.0	298	183	132	103	84	72	62
	8.0	323	202	147	116	95	81	70

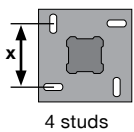

Result: L1 [inch]	F [lbs]							
	100	150	200	300	400	500	600	700
x [inch]	3.0	22.75	14.50	10.50	6.50	4.50	3.25	2.50
	4.0	30.25	19.50	14.00	8.75	6.00	4.25	3.25
	5.0	37.75	24.25	17.50	10.75	7.50	5.50	4.00
	6.0	45.50	29.25	21.25	13.00	9.00	6.50	5.00
	7.0	53.00	34.25	24.75	15.25	10.50	7.75	5.75
	8.0	60.50	39.00	28.25	17.50	12.00	8.75	6.75

Result: Load F [lbs]	L1 [inch]							
	6.0	12.0	18.0	24.0	30.0	36.0	42.0	48.0
x [inch]	3.0	323	180	124	95	77	65	49
	4.0	404	231	162	124	101	85	65
	5.0	476	279	197	153	124	105	80
	6.0	539	323	231	180	147	124	108
	7.0	596	365	263	206	169	143	124
	8.0	647	404	294	231	190	162	141

NOTE: load capacity used for calculation $N_{rec} = 405 \text{ lb (axial)} / V_{rec} = 405 \text{ lb (shear)}$

[FASTENER SYSTEM](#)
[FASTENER OVERVIEW](#)
[FASTENER TECHNICAL DETAILS](#)
[APPLICATION OVERVIEW](#)
[HOW TO USE THIS DOCUMENT](#)
[DISCLAIMER](#)

FASTENING EQUIPMENT SUPPORT WITH X-ST-GR

Two / Four X-ST-GR Threaded studs

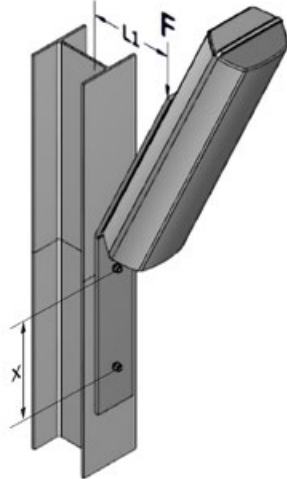

Application

- Fastening of lamps, signals, sensors, on inclined cantilever support, fastened on a vertical structure
- Support is fastened by two / four X-ST-GR (vertical distance x)
- L1 is the distance of the load center (~middle of the load) to the vertical structure surface
- Load F is the acceptable total load (all dead load including)

Boundary conditions

- These values are ONLY reflecting capacity of X-ST-GR threaded stud. Structural analysis of support / structure is NOT in Hilti scope. See the detailed statements in disclaimer—2018/05/04
- Shear load fully carried by one / two top X-ST-GR (worst-case)
- Load F acting at the distance of L1 from structure surface

Technical assessment – maximum of L1 and F (depending on load F or lever arm length L1 and X-ST-GR distance x)

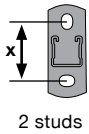

Result: L1 [inch]	F [lbs]							
	100	150	200	300	400	500	600	700
x [inch]	3.0	9.00	5.00	3.00	1.00			
	4.0	12.00	6.75	4.00	1.25			
	5.0	15.00	8.25	5.00	1.50			
	6.0	18.25	10.00	6.00	2.00			
	7.0	21.25	11.75	7.00	2.25			
	8.0	24.25	13.50	8.00	2.75			

Result: Load F [lbs]	L1 [inch]								
	6.0	12.0	18.0	24.0	30.0	36.0	42.0	48.0	
x [inch]	3.0	135	81	58	45	37	31	27	24
	4.0	162	101	73	58	47	40	35	31
	5.0	184	119	88	70	58	49	43	38
	6.0	202	135	101	81	67	58	50	45
	7.0	218	149	113	91	77	66	58	51
	8.0	231	162	124	101	85	73	65	58

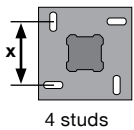

Result: L1 [inch]	F [lbs]							
	100	150	200	300	400	500	600	700
x [inch]	3.0	18.25	10.00	6.00	2.00			
	4.0	24.25	13.50	8.00	2.75			
	5.0	30.25	16.75	10.00	3.25			
	6.0	36.50	20.25	12.25	4.00			
	7.0	42.50	23.75	14.25	4.75			
	8.0	48.50	27.00	16.25	5.50			

Result: Load F [lbs]	L1 [inch]								
	6.0	12.0	18.0	24.0	30.0	36.0	42.0	48.0	
x [inch]	3.0	270	162	116	90	73	62	54	47
	4.0	323	202	147	116	95	81	70	62
	5.0	368	238	176	139	116	99	86	76
	6.0	404	270	202	162	135	116	101	90
	7.0	436	298	226	183	153	132	116	103
	8.0	462	323	249	202	170	147	129	116

NOTE: load capacity used for calculation $N_{rec} = 405 \text{ lb (axial)} / V_{rec} = 405 \text{ lb (shear)}$

FASTENER SYSTEM	FASTENER OVERVIEW	FASTENER TECHNICAL DETAILS	APPLICATION OVERVIEW
HOW TO USE THIS DOCUMENT	DISCLAIMER		

FASTENING JUNCTION BOXES / SWITCHES WITH X-ST-GR

X-ST-GR Threaded stud

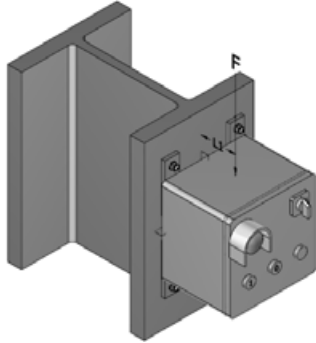

Application

- Fastening of junction boxes, switches on a vertical structure
- Element is fastened by X-ST-GR

Boundary conditions

- These values are ONLY reflecting capacity of X-ST-GR threaded stud. Structural analysis of support / structure is NOT in Hilti scope. See the detailed statements in disclaimer—2018/05/04
- Technical data are based on technical data binder for X-ST-GR (06 / 2018), always refer to latest technical data binder for X-ST-GR

Technical data — always refer to latest technical data binder for X-ST

Recommended load	X-ST
Base material thickness	$t_{II} \geq 6 \text{ mm (0.24")}$
Base material	Steel $R_m \geq 350 \text{ MPa}$
Tension, N_{rec} [kN]	1.8
Shear, V_{rec} [kN]	1.8
Moment, M_{rec} [Nm]	5.5

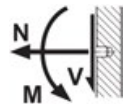

Application limit

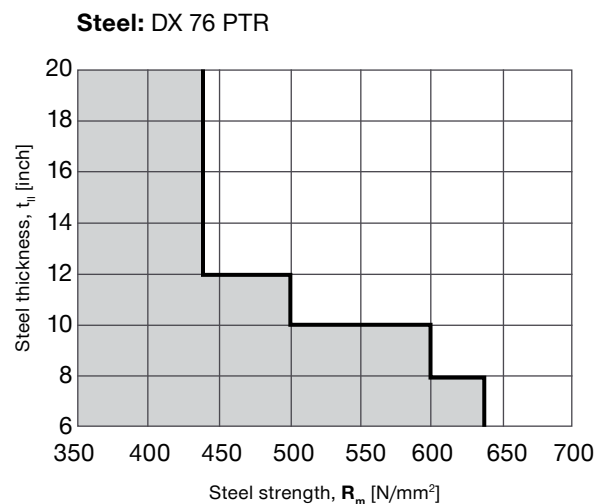
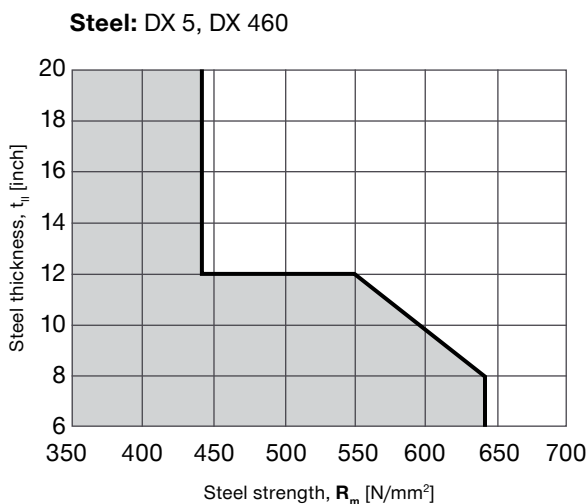

X-ST-GR CATALOG PAGES

Description	Base Material	Environment	Item Number
X-ST-GR M8/10 P8	Steel	Mildly corrosive	2122460



Description	Item Number
DX 76 PTR	Local item
DX 5 GR	Local item
X-5 460 F8 N15 Fastener guide	304530
X-5 460 P8 Piston	373297
Cartridge 6.8/11 M10 STD red	416474
Cartridge 6.8/11 M10 STD black	416475
X-76-F-8-GR-PTR Fastener guide	388852
Cartridge 6.8/18 M10 .27 cal C-T yellow	416483
Cartridge 6.8/18 M10 .27 cal C-T red	416484



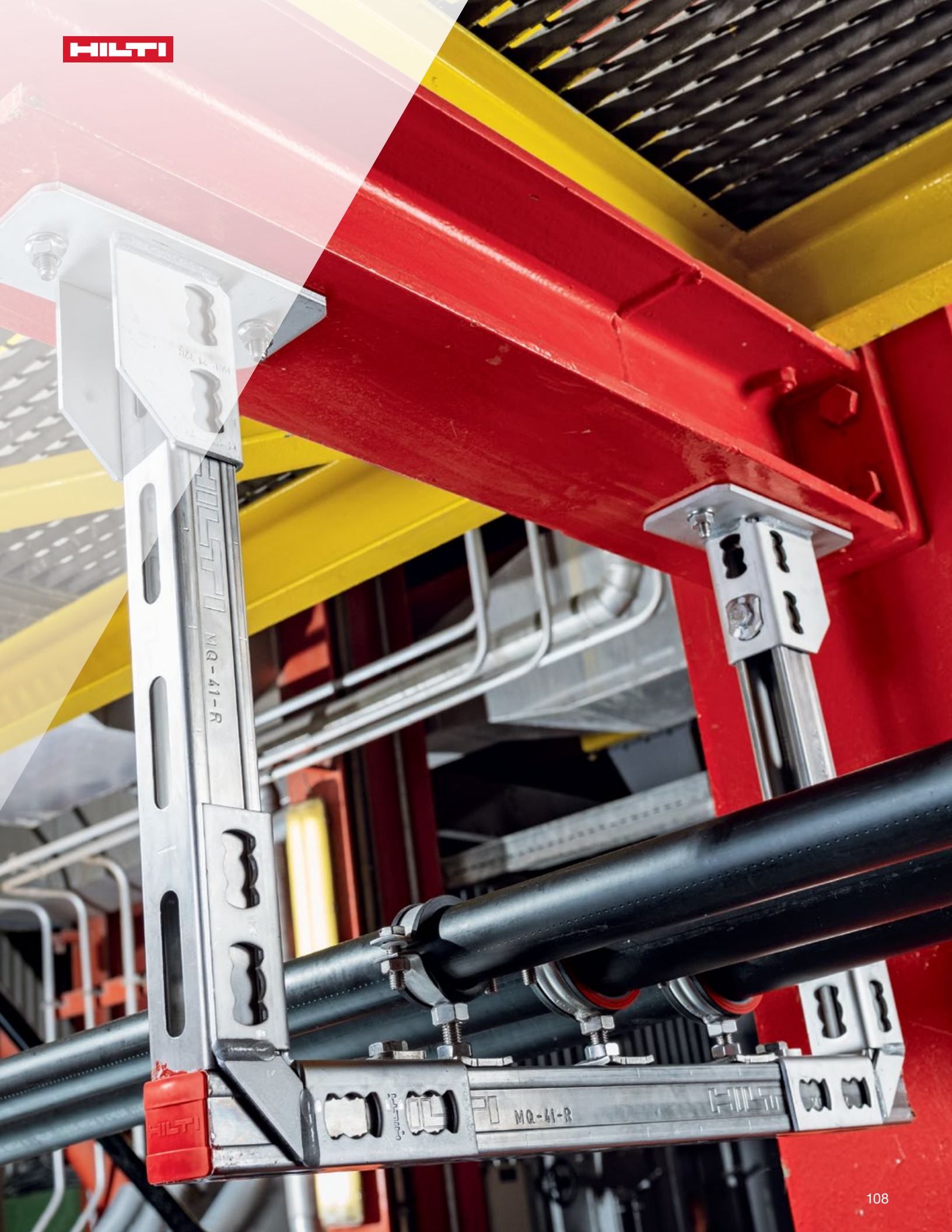

TYPICALS

Detail

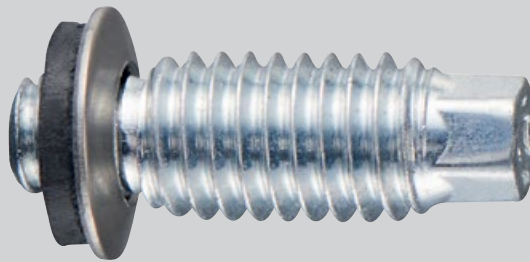

BRACED CANTILEVER

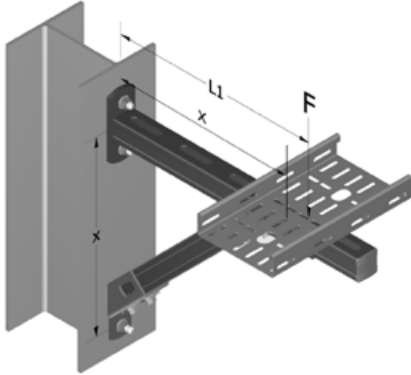

Application

- Fastening of cable trays, pipes on a horizontal, braced cantilever support, fastened on a vertical structure
- Support is fastened by two / four fasteners on both support and baseplate
- L_1 is the distance of the load center to the vertical structure surface
- x is the distance of the baseplates (and of brace joint to vertical structure surface)
- The angle of the brace is assumed to be 45°
- Load F is the acceptable total load (all dead load including)

Boundary conditions and assumptions

- Results of calculation are ONLY reflecting capacity of Hilti fasteners. Structural analysis of support / base structure is NOT in Hilti scope.
- All typical calculations are based on the capacity that is mentioned in the description of the fasteners—please refer to the respective detailed technical description. Results are rounded for simplification and to harmonize metric and imperial units.
- **Load case:** acceptable load F is acting in the center of the cable tray, pipe in a distance of L_1 to the support structure.
- **Assumption:** calculation is based on rigid system model, without deformation of baseplate or cantilever.
- **Assumption:** the shear loads in top and bottom baseplate are assumed to be carried only by the threaded stud(s) which also carry the tensile load, this is therefore a worst-case scenario.
- **Assumption:** considered loadings are only the static loads of the cable tray, pipe or other installed elements and the weight of the support itself. The load is always acting in the center of the cable tray, pipe or installed elements, the dimension L_1 is from that point to the fasteners plane—please see the description in the respective examples. No other loads (e.g. wind load or loads due to installation / transportation) are known and in scope of the calculation.
- **Assumption:** there is no load in axis of the cable tray or pipe due to thermal expansion or other phenomena.

T-POST (FLOOR)

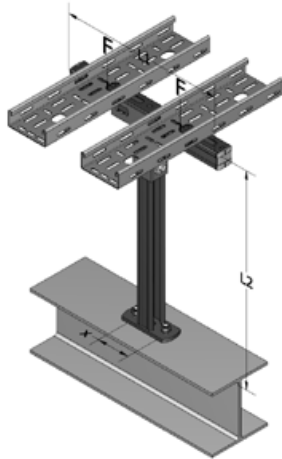

Application

- Fastening of cable trays, pipes on a T-Post, which is fastened on a horizontal structure
- Support is fastened by two / four fasteners (distance x)
- $L1$ is the total width of the T-Post, $L2$ is fix set to 1000 mm
- Load F is the acceptable total load (all dead load including)

Boundary conditions and assumptions

- Results of calculation are ONLY reflecting capacity of Hilti fasteners. Structural analysis of support / base structure is NOT in Hilti scope.
- All typical calculations are based on the capacity that is mentioned in the description of the fasteners—please refer to the respective detailed technical description. Results are rounded for simplification and to harmonize metric and imperial units.
- **Load case A:** 30% of acceptable load F is acting as shear load, perpendicular to the cable tray axis (F is not yet applied, as worst-case).
- **Load case B:** Load F is introduced asymmetrically, acting in the center of one of the upper arms of the T-Post.
- **Assumption:** calculation is based on rigid system model, without deformation of baseplate or cantilever.
- **Assumption:** shear loads in baseplate are assumed to be carried only by the threaded stud(s) which also carry the tensile load, this is therefore a worst-case scenario.
- **Assumption:** considered loadings are only the static loads of the cable tray, pipe or other installed elements and the weight of the support itself. No other loads (e.g. wind load or loads due to installation / transportation) are known and in scope of the calculation.
- **Assumption:** there is no load in axis of the cable tray or pipe due to thermal expansion or other phenomena.

T-POST (CEILING)

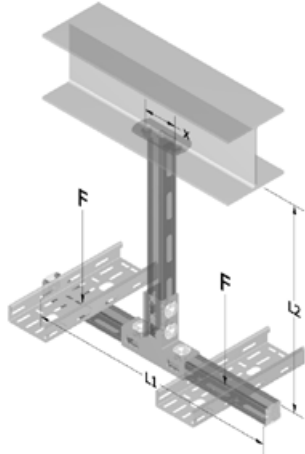

Application

- Fastening of cable trays, pipes on a T-Post, which is fastened on a horizontal structure
- Support is fastened by two / four fasteners (distance x)
- L1 is the total width of the T-Post, L2 is fix set to 1000 mm
- Load F is the acceptable total load (all dead load including)

Boundary conditions and assumptions

- Results of calculation are ONLY reflecting capacity of Hilti fasteners. Structural analysis of support / base structure is NOT in Hilti scope.
- All typical calculations are based on the capacity that is mentioned in the description of the fasteners—please refer to the respective detailed technical description. Results are rounded for simplification and to harmonize metric and imperial units.
- **Load case A:** 30% of acceptable load F is acting as shear load, perpendicular to the cable tray axis (F is yet applied, as worst-case).
- **Load case B:** Load F is introduced asymmetrically, acting in the center of one of the upper arms of the T-Post.
- **Assumption:** calculation is based on rigid system model, without deformation of baseplate or cantilever.
- **Assumption:** shear loads in baseplate are assumed to be carried only by the threaded stud(s) which also carry the tensile load, this is therefore a worst-case scenario.
- **Assumption:** considered loadings are only the static loads of the cable tray, pipe or other installed elements and the weight of the support itself. No other loads (e.g. wind load or loads due to installation / transportation) are known and in scope of the calculation.
- **Assumption:** there is no load in axis of the cable tray or pipe due to thermal expansion or other phenomena.



Hilti, Inc.
Legacy Tower, Suite 1000
7250 Dallas Parkway | Plano, TX 75024

Customer Service: 1-800-879-8000
www.hilti.com
en español: 1-800-879-5000