

47% [Zoom icons]

Heavy Hex Head ASTM F 15...

Create report

MESSAGES

Calculation as per AISC Design Guide is restricted to designs with anchors placed in symmetrical lines.

R - user is responsible for evaluating the hole bearing capacity in case of shear forces.

Not all design results are valid. Report export is therefore not possible. Please change an input or delete a specific load combination if report export is needed.

No standard item number available. Please contact Hilti to check feasibility of supply.

Calculations for AISC Design Guide 1 utilize a rigid base plate assumption. It is possible to review the rigid assumption using CBFEM. To learn more, click here.

Use CBFEM

R - The anchor calculation is based on a rigid anchor plate assumption.

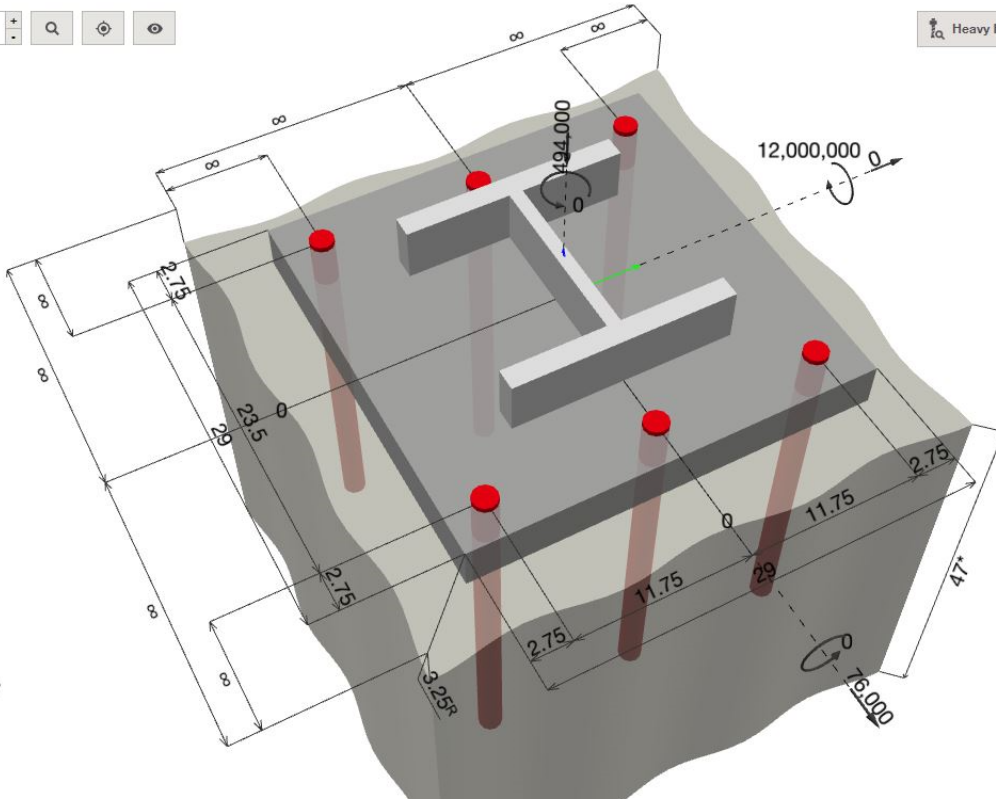

47% [Zoom icons]

Change to 2D

Heavy Hex Head ASTM F 15...

Create report

MESSAGES

Anchors (1, 3, 4, 6) are too close to the edge of the anchor plate (min = 2.7205 in. in).

Adjust plate size

Adjust anchor spacing

Calculation as per AISC Design Guide is restricted to designs with anchors placed in symmetrical lines.

R - user is responsible for evaluating the hole bearing capacity in case of shear forces.

Not all design results are valid. Report export is therefore not possible. Please change an input or delete a specific load combination if report export is needed.

No standard item number available. Please contact Hilti to check feasibility of supply.

Calculations for AISC Design Guide 1 utilize a rigid base plate assumption. It is possible to review the rigid assumption

