



MP-SPN

Abrazadera MP-SPN para el soporte de una red sprinkler



MP-SPN

ABRAZADERA MP-SPN

Aplicaciones

- Instalaciones sprinkler

Ventajas

- Inserte la tubería, cuélguela y ajústela. Ahorrando tiempo durante la instalación.
- Nivelación sencilla gracias a la tuerca del regulador de altura
- Instalación sencilla de tuberías gracias a la tuerca de ajuste de altura del aspersor premontada
- Suspensión de tuberías con homologación VdS, FM y UL



Datos técnicos

- Composición del material : DX51D Z275 - DIN EN 10327
- Acabado: Galvanizado

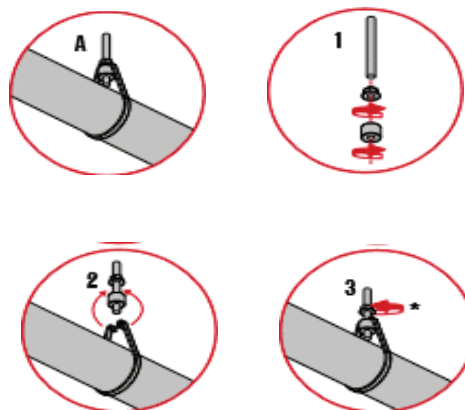
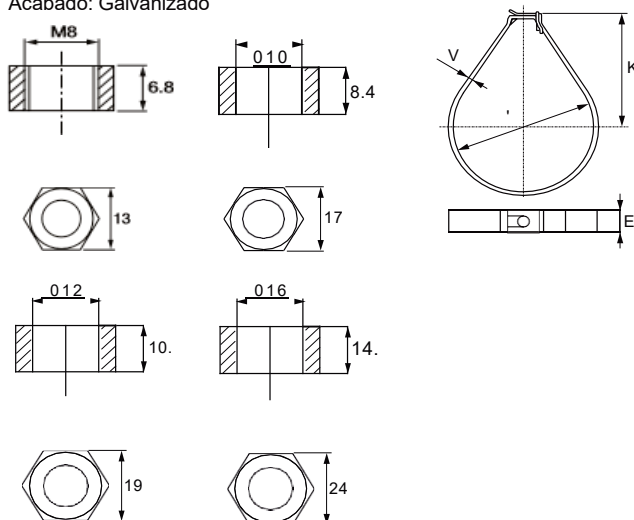

CÓDIGOS DE ARTÍCULOS Y DIMENSIONES

Descripción	Rango de fijación	Tamaño de tubería nominal (imperial)	Ancho y espesor de la sección transversal (b x s)	Carga máxima F (kN)	Dist. Centro de tubo a parte superior - h	Peso	Cantidad min. de venta	Código
M8 MP-SPN 3/4"	27 - 28 mm	3/4"	9 x 2 mm	2,0	55 mm	60 g	100	2180264
M8 MP-SPN 1"	34 - 35 mm	1"	9 x 2 mm	2,0	60 mm	63 g	100	2180265
M8 MP-SPN 1 1/4"	42 - 45 mm	1 1/4"	9 x 2 mm	2,0	65 mm	63 g	50	2180266
M8 MP-SPN 1 1/2"	48 - 51 mm	1 1/2"	9 x 2 mm	2,0	70 mm	71 g	50	2180267
M8 MP-SPN 2"	57 - 64 mm	2"	9 x 2 mm	2,0	78 mm	76 g	50	2180268
M10 MP-SPN 3/4"	27 - 28 mm	3/4"	9 x 2 mm	2,0	50 mm	78 g	100	2180269
M10 MP-SPN 1"	34 - 35 mm	1"	9 x 2 mm	2,0	60 mm	81 g	100	2180410
M10 MP-SPN 1 1/4"	42 - 45 mm	1 1/4"	9 x 2 mm	2,0	65 mm	86 g	50	2180411
M10 MP-SPN 1 1/2"	48 - 51 mm	1 1/2"	9 x 2 mm	2,0	70 mm	89 g	50	2180412
M10 MP-SPN 2"	57 - 64 mm	2"	9 x 2 mm	2,0	78 mm	94 g	50	2180413
M10 MP-SPN 2 1/2"	70 - 76 mm	2 1/2"	10 x 3 mm	3,5	95 mm	137 g	25	2180414
M10 MP-SPN 3"	83 - 89 mm	3"	10 x 3 mm	3,5	108 mm	147 g	25	2180415
M10 MP-SPN 4"	108 - 114 mm	4"	10 x 3 mm	3,5	135 mm	174 g	25	2180416
M12 MP-SPN 133	133 - 133 mm	-	10 x 3 mm	5,0	140 mm	211 g	25	2180417
M12 MP-SPN 5"	140 - 140 mm	5"	10 x 3 mm	5,0	148 mm	217 g	25	2180418
M12 MP-SPN 159	159 - 159 mm	-	10 x 3 mm	5,0	165 mm	232 g	25	2180419
M12 MP-SPN 6"	165 - 168 mm	6"	10 x 3 mm	5,0	172 mm	239 g	25	2180420
M16 MP-SPN 219	219 - 219 mm	-	16 x 3 mm	8,5	215 mm	470 g	10	2180421