

**MECHANICAL SUPPORT MEMBER THROUGH CONCRETE WALL
OR BLOCK WALL ASSEMBLY**

F-RATING = 2-HR.
T-RATING = 0-HR.

WJ7123b.010915

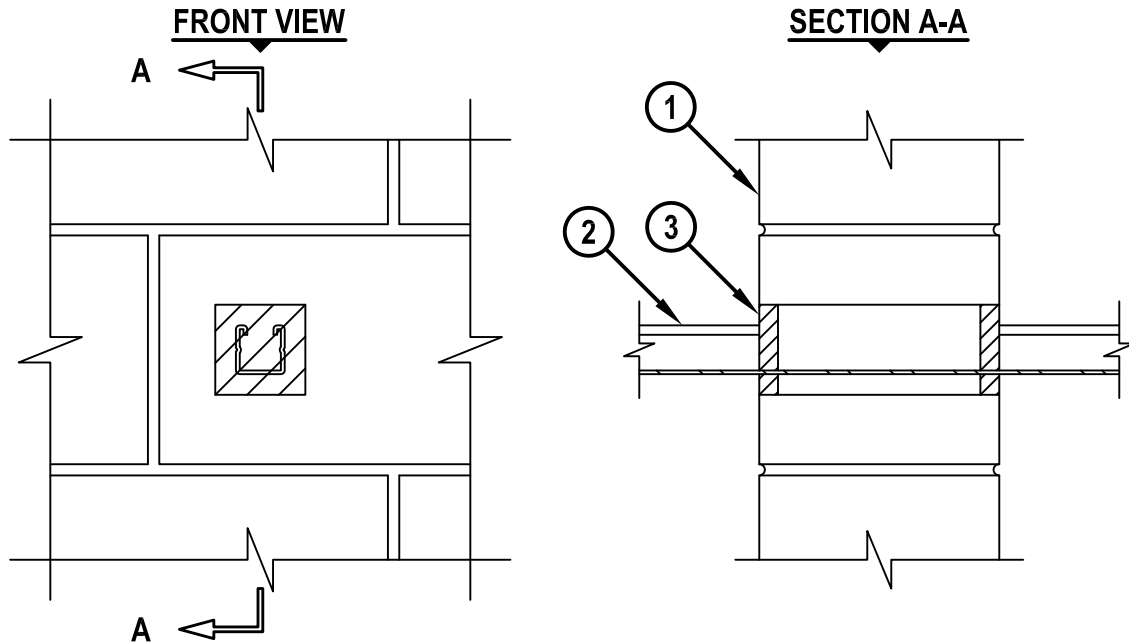

1. CONCRETE WALL ASSEMBLY (2-HR. FIRE-RATING) :
 - A. LIGHTWEIGHT OR NORMAL WEIGHT CONCRETE WALL (MINIMUM 5" THICK).
 - B. ANY UL/cUL CLASSIFIED CONCRETE BLOCK WALL.
2. PENETRATING ITEM TO BE ONE OF THE FOLLOWING :
 - A. MAXIMUM 1-5/8" x 1-5/8" GALVANIZED OR PAINTED STEEL CHANNEL STRUT (MINIMUM 0.105" THICK).
 - B. MAXIMUM 3-1/4" x 1-5/8" GALVANIZED OR PAINTED STEEL "H" STRUT (MINIMUM 0.105" THICK).
 - C. MAXIMUM 3/8" DIAMETER UNJACKETED GALVANIZED STEEL CABLE.
 - D. MAXIMUM 1" DIAMETER GALVANIZED THREADED STEEL ROD.
 - E. MAXIMUM 2" x 2" x 1/8" THICK STEEL ANGLE.
3. MINIMUM 5/8" DEPTH HILTI FS-ONE MAX OR FS-ONE INTUMESCENT FIRESTOP SEALANT OR HILTI CP 606 FLEXIBLE FIRESTOP SEALANT.

NOTES : 1. MAXIMUM SIZE OF OPENING = 5" x 3" [OR MAXIMUM 3" DIAMETER].
 2. ANNULAR SPACE = MINIMUM 1/8", MAXIMUM 7/8".
 3. PENETRANT MAY BE INSTALLED AT AN ANGLE NOT GREATER THAN 45° FROM PERPENDICULAR.
 4. WHEN HILTI CP 606 FLEXIBLE FIRESTOP SEALANT IS USED ON AN ANGLED PENETRANT, FIRMLY PACK 1/2" THICKNESS OF MINERAL WOOL (MIN. 4 PCF DENSITY) INTO OPENING AS A PERMANENT FORM.



HILTI, Inc.
Tulsa, Oklahoma USA (800) 879-8000

Sheet	1 of 1
Scale	5/32" = 1"
Date	Jan. 09, 2015

Drawing No.

**WJ
7123b**