

HIT-HY 50 injection mortar with HIT-AN/HIT-IG

Features:	
	- base material: solid brick, sand-lime block
	- two-component hybrid mortar
	- clean and simple in use
	- correct mixing ratio
	- rapid curing
	- versatile in use
	- small edges distances and anchor spacing
Material	
Anchor rod:	- HIT-AN: steel, grade 3.6, DIN EN 20898-1 - galvanised to 5 microns
Internally threaded sleeve:	- HIT-IG: steel, DIN EN 10277-3 - galvanised to 5 microns
Mortar:	- foil pack: 330 ml, 500 ml
Dispenser:	- MD 2000, BD 2000, P3000 F, P5000 HY



Small edge distance / spacing



Fire resistance

Basic loading data (for a single anchor): HIT-HY 50 with HIT-AN or HIT-IG

All data on this page applies to

- solid brick, $f_k = 33 \text{ N/mm}^2$
- The load values are only valid if holes are drilled with TE rotary hammers.
- no edge distance and spacing influence
- correct setting (See setting operations page 292)

Characteristic resistance, R_k [kN]:

HIT-AN

Anchor size	M 8	M 10	M 12
Tensile, N_{Rk}	7.5	9.0	10.5
Shear, V_{Rk}	9.0	10.5	12.0

HIT-IG

M 8	M 10	M 12
9.0	12.0	12.0
9.0	10.5	12.0

Design resistance, R_d [kN]:

HIT-AN

Anchor size	M 8	M 10	M 12
Tensile, N_{Rd}	3.4	4.2	4.9
Shear, V_{Rd}	4.2	4.9	5.6

HIT-IG

M 8	M 10	M 12
4.2	5.6	5.6
4.2	4.9	5.6

Recommended load, L_{rec} [kN]:

HIT-AN

Anchor size	M 8	M 10	M 12
Tensile, N_{Rec}	2.5	3.0	3.5
Shear, V_{Rec}	3.0	3.5	4.0
T_{inst} [Nm]	7.5	12.5	12.5

HIT-IG

M 8	M 10	M 12
3.0	4.0	4.0
3.0	3.5	4.0
7.5	12.5	12.5

HIT-HY 50 injection mortar with HIT-AN/HIT-IG

Basic loading data (for a single anchor): HIT-HY 50 with HIT-AN and HIT-IG

All data in this section applies to

- sand lime block, $f_k = 27 \text{ N/mm}^2$
- The load values are only valid if the holes are drilled with TE rotary hammers.
- No edge distance and spacing influence
- correct setting (See setting operations page 292)

Characteristic resistance, R_k [kN]:

HIT-AN

Anchor	M 8	M 10	M 12
Tensile, N_{Rk}	10.5	13.5	16.5
Shear, V_{Rk}	9.0	10.5	12.0

HIT-IG

M 8	M 10	M 12
10.5	16.5	16.5
9.0	10.5	12.0

Design resistance, R_d [kN]:

HIT-AN

Anchor size	M 8	M 10	M 12
Tensile, N_{Rd}	4.9	6.3	7.7
Shear, V_{Rd}	4.2	4.9	5.6

HIT-IG

M 8	M 10	M 12
4.9	7.7	7.7
4.2	4.9	5.6

Recommended load, L_{rec} [kN]:

HIT-AN

Anchor size	M 8	M 10	M 12
Tensile, N_{Rec}	3.5	4.5	5.5
Shear, V_{Rec}	3.0	3.5	4.0
T_{inst} [Nm]	12.0	25.0	25.0

HIT-IG

M 8	M 10	M 12
3.5	5.5	5.5
3.0	3.5	4.0
12.0	25.0	25.0

Edge distance and spacing: edge distance, $c_{min} = 10 \text{ cm}$
spacing distance, $s_{min} = 10 \text{ cm}$

Setting details

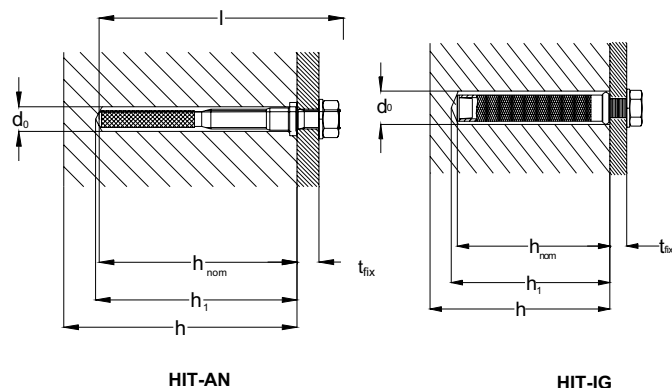

HIT-HY 50 injection mortar with HIT-AN/HIT-IG

HIT-AN

Anchor size		M 8	M 10	M 12	
		Setting detail			
d ₀	[mm]	Drill bit diameter	10	12	12
h ₁	[mm]	Hole depth	82	82	82
t _{fix}	[mm]	Max. fixture thickness	9	16	19
h _{nom}	[mm]	Min. anchorage depth	80	80	80
l	[mm]	Anchor length	100	110	115
S _w	[mm]	Width across flats	13	17	19
d _n	[mm]	Max. clearance hole	11	13	15
h _{min}	[cm]	Min. base material thickness	12	14	16
		Injected volume (trigger pulls)	1	2	2
		Drill bit	TE-CX-	10/22	12/22

HIT-IG

Anchor size		M 8	M 10	M 12	
		Setting details			
d ₀	[mm]	Drill bit diameter	14	18	18
h ₁	[mm]	Hole depth	82	82	82
h _{nom}	[mm]	Min. anchorage depth	80	80	80
l _G	[mm]	Thread length	full length		
l	[mm]	Anchor length	80	80	80
d _n	[mm]	Max. clearance hole	11	13	15
h _{min}	[cm]	Min. base material thickness	12	14	16
		Injected volume (trigger pulls)	2	2	2
		Drill bit	TE-CX-	14/22	-
		Drill bit	TE-T-	-	18/32

Note: To ensure that optimal holding power is obtained, the first **two trigger pulls** of mortar after opening a **330 ml** foil pack of Hilti HIT-HY 50 must be thrown away. One trigger pull is approx. 8 ml mortar when using the MD 2000.

Temperature of the basematerial °C	Gel time	Curing time
5	15 min.	120 min.
10	8 min.	90 min.
20	4 min.	60 min.
30	2 min.	45 min.
40	1 min.	30 min.

The mortar cartridge must have a temperature of at least +5 °C

Installation equipment

Rotary hammer (TE2, TE6, TE6A, TE15, TE15-C, TE18-M, TE35, TE55 or TE 76), a drill bit, a brush, a blow out pump, the MD 2000 or BD2000 (P3000 F, P5000 HY) dispenser and a torque wrench.

Setting operations

HIT-AN

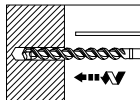

Drill hole

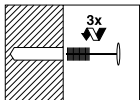
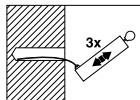

Clean hole.

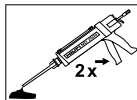
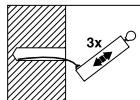

Throw away first 2 trigger pulls.

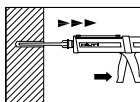

Inject mortar

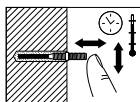

Insert and adjust anchor / fastener.
Observe t_{set}

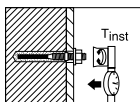

Load anchor / fastener.
Observe t_{cure}

HIT-IG

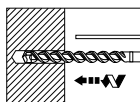

Drill hole

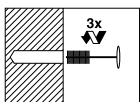
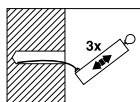

Clean hole.

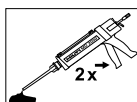
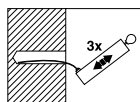

Throw away first 2 trigger pulls.

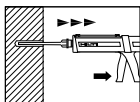

Inject mortar

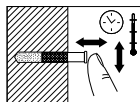

Insert and adjust anchor / fastener.
Observe t_{set}

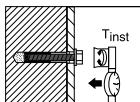

Load anchor / fastener.
Observe t_{cure}