

UL/cUL SYSTEM NO. W-L-3415

CABLE BUNDLE THROUGH GYPSUM WALL ASSEMBLY (MEMBRANE)

F-RATING = 1-HR. OR 2-HR.

T-RATING = 1-HR. OR 2-HR.

L-RATING AT AMBIENT = LESS THAN 1 CFM / OPENING

L-RATING AT 400°F = LESS THAN 1 CFM / OPENING

WL3415a.082915

FRONT VIEW

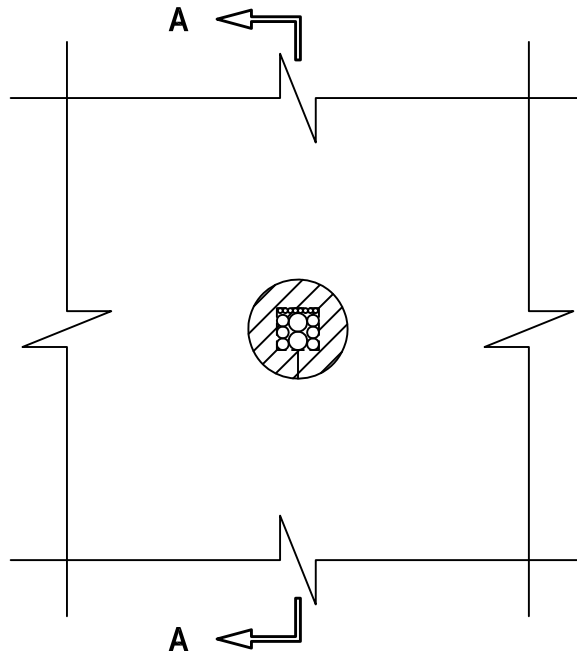

SECTION A-A

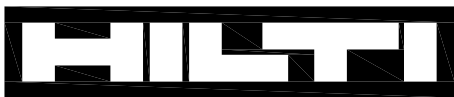
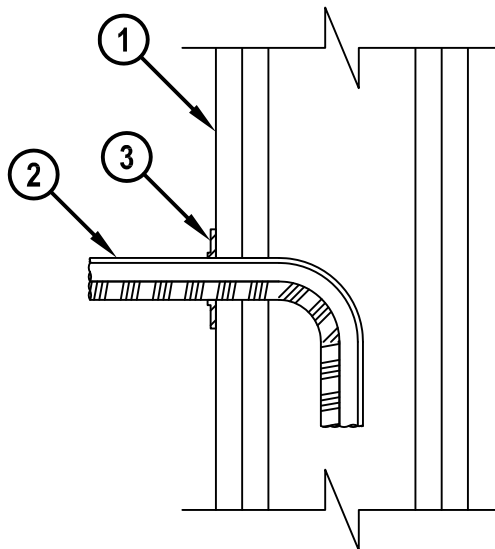

Hilti Firestop Systems

HILTI, Inc.
Plano, Texas USA (800) 879-8000

Sheet	1 of 2
Scale	7/32" = 1"
Date	Aug. 29, 2015

Drawing No.

**WL
3415a**

Saving Lives through Innovation and Education

CABLE BUNDLE THROUGH GYPSUM WALL ASSEMBLY (MEMBRANE)

F-RATING = 1-HR. OR 2-HR.

T-RATING = 1-HR. OR 2-HR.

L-RATING AT AMBIENT = LESS THAN 1 CFM / OPENING

L-RATING AT 400°F = LESS THAN 1 CFM / OPENING

WL3415a.082915

1. GYPSUM WALL ASSEMBLY (UL/cUL CLASSIFIED U300, U400, V400, OR W400 SERIES) (1-HR. OR 2-HR. FIRE-RATING) (2-HR. SHOWN) TO INCLUDE THE FOLLOWING CONSTRUCTION FEATURES :
 - A. [NOT SHOWN] WOOD STUDS TO CONSIST OF NOMINAL 2" x 4" LUMBER (SPACED MAXIMUM 16" OC). STEEL STUDS TO BE MINIMUM 3-1/2" WIDE (SPACED MAXIMUM 24" OC).
 - B. NOMINAL 5/8" THICK GYPSUM WALLBOARD. TYPE, NUMBER OF LAYERS, AND SHEET ORIENTATION AS SPECIFIED IN THE INDIVIDUAL UL DESIGN.
2. SINGLE OR TIGHT BUNDLE TO BE A COMBINATION OF ANY OF THE FOLLOWING :
 - A. MAXIMUM 3/C NO. 8 AWG NM COPPER CONDUCTOR (ROMEX) CABLE WITH PVC INSULATION AND JACKET.
 - B. MAXIMUM 7/C NO. 12 AWG COPPER CONDUCTOR CONTROL CABLE WITH PVC OR XLPE JACKET AND INSULATION.
 - C. MAXIMUM 100 PAIR NO. 24 AWG COPPER CONDUCTOR TELECOMMUNICATION CABLE WITH PVC OR PLENUM RATED INSULATION AND JACKETING.
 - D. MAXIMUM 4 PAIR NO. 22 AWG CAT 5 OR 6 COMPUTER CABLE WITH PVC OR PLENUM RATED INSULATION AND JACKETING.
 - E. MAXIMUM RG 6/U COAXIAL CABLE WITH FLUORINATED ETHYLENE OR PVC INSULATION AND JACKETING (MAXIMUM 1/2" DIAMETER).
 - F. MAXIMUM 24 FIBER-OPTIC CABLE WITH PVC OR PE JACKET AND INSULATION.
 - G. MAXIMUM 2/C NO. 18 AWG COPPER CONDUCTOR FIRE ALARM CABLE WITH OR WITHOUT A JACKET UNDER A METAL ARMOR (AFC CABLE SYSTEMS, INC).
 - H. MAXIMUM 3/C NO. 10 AWG COPPER CONDUCTOR METAL CLAD CABLE.
3. HILTI CFS-D 1" FIRESTOP CABLE DISC PRESSED FIRMLY AROUND THE CABLE/CABLE BUNDLE LAPPING NOMINAL 5mm ONTO CABLES COMPLETELY COVERING OPENING AND FIRMLY PRESSED TO LAP ONTO THE WALL. DISC SEAM TO BE FIRMLY PRESSED AND SEALED TIGHT.

NOTES: 1. OPENING MAY BE ROUND, RECTANGULAR, OR IRREGULAR WITH A MAXIMUM DIAMETER OF DIMENSION OF 1".

2. CABLES MAY REPRESENT 0% TO 100% OF VISUAL FILL OF OPENING.

3. ANNULAR SPACE BETWEEN CABLE AND PERIPHERY OF OPENING = MINIMUM 0".



HILTI, Inc.
Plano, Texas USA (800) 879-8000

Sheet	2 of 2
Scale	-
Date	Aug. 29, 2015

Drawing No.

**WL
3415a**