

www.hilti.com

Company:		Page:	1
Address:		Specifier:	
Phone   Fax:		E-Mail:	
Design:	Concrete - May 14, 2026	Date:	5/14/2026
Fastening point:			

**Specifier's comments:**

**1 Input data**

Metal deck:	Vulcraft 2VLI
Metal deck type:	W1
Anchor installation:	In the lower flute of concrete-filled metal deck
<b>Anchor type and diameter:</b>	<b>Kwik Bolt TZ2 - CS 1/2 (3 1/4)</b>
Item number:	2210255 KB-TZ2 1/2x4 1/2
Specification text:	HILTI Ø 1/2 IN KWIK BOLT TZ2 - CS WITH 3.75 IN NOMINAL EMBEDMENT DEPTH PER ICC-ES ESR-4266 , HAMMER DRILL BIT INSTALLATION PER MPII
Effective embedment depth:	$h_{ef,act} = 3.250$ in., $h_{nom} = 3.750$ in.
Material:	Carbon Steel
Evaluation Service Report:	ESR-4266
Issued   Valid:	12/1/2025   12/1/2027
Proof:	Design Method ACI 318-19 / Mech in concrete over metal deck installation
Stand-off installation:	
Profile:	
Base material:	uncracked concrete, 3000, $f'_c = 3,000$ psi; $h = 4.000$ in.
<b>Installation:</b>	<b>Hammer drilled hole, Installation condition: Dry</b>





www.hilti.com

Company:  
Address:  
Phone | Fax: |  
Design: Concrete - May 14, 2026  
Fastening point:

Page: 2  
Specifier:  
E-Mail:  
Date: 5/14/2026

Geometry [in.] & Loading [lb, in.lb]

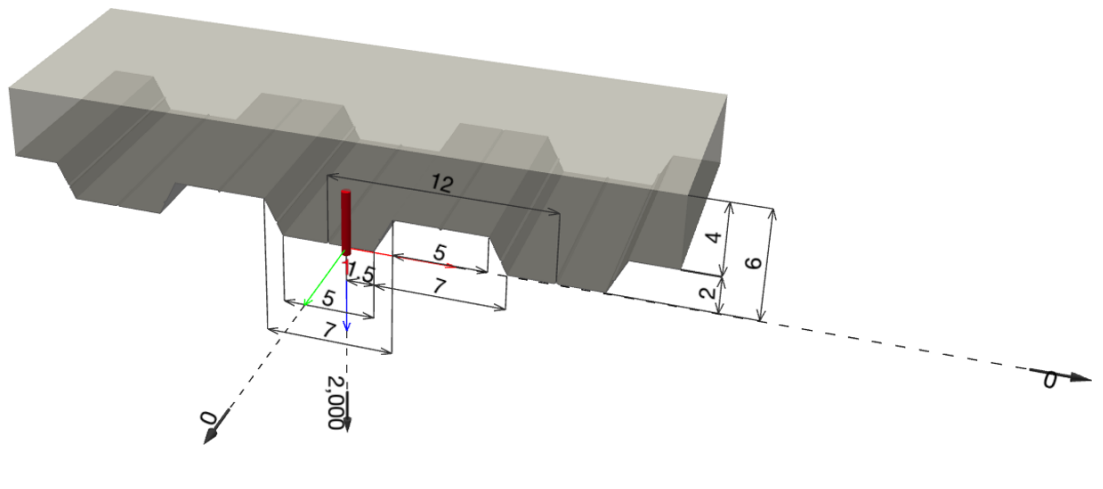



www.hilti.com

Company:		Page:	3
Address:		Specifier:	
Phone   Fax:		E-Mail:	
Design:	Concrete - May 14, 2026	Date:	5/14/2026
Fastening point:			

1.1 Design results

Case	Description	Forces [lb] / Moments [in.lb]	Seismic	Max. Util. Anchor [%]
1	Combination 1	N = 2,000; V <sub>x</sub> = 0; V <sub>y</sub> = 0; M <sub>x</sub> = 0; M <sub>y</sub> = 0; M <sub>z</sub> = 0;	no	66

2 Load case/Resulting anchor forces

Anchor reactions [lb]

Tension force: (+Tension, -Compression)

Anchor	Tension force	Shear force	Shear force x	Shear force y
1	2,000	0	0	0

3 Tension load

	Load N <sub>ua</sub> [lb]	Capacity $\phi$ N <sub>n</sub> [lb]	Utilization $\beta_N = N_{ua} / \phi N_n$	Status
Steel Strength*	N/A	N/A	N/A	N/A
Pullout Strength*	2,000	3,066	66	OK
Concrete Breakout Failure**	N/A	N/A	N/A	N/A

\* highest loaded anchor    \*\*anchor group (anchors in tension)



www.hilti.com

Company:		Page:	4
Address:		Specifier:	
Phone   Fax:		E-Mail:	
Design:	Concrete - May 14, 2026	Date:	5/14/2026
Fastening point:			

3.1 Pullout Strength

$$N_{pn,Deck,f'_c} = N_{p,Deck,3000} \lambda_a (f'_c/3000)^\alpha$$

refer to ICC-ES ESR-4266  
 ACI 318-19 Table 17.5.2

$$\phi N_{pn,Deck,f'_c} \geq N_{ua}$$

Variables

$f'_c$ [psi]	$\alpha$	$\lambda_a$	$N_{p,Deck,3000}$ [lb]
3,000	0.350	1.000	4,717

Calculations

$$\frac{(f'_c/3000)^\alpha}{1.000}$$

Results

$N_{pn,Deck,f'_c}$ [lb]	$\phi_{concrete}$	$\phi N_{pn,Deck,f'_c}$ [lb]	$N_{ua}$ [lb]
4,717	0.650	3,066	2,000



www.hilti.com

Company:		Page:	5
Address:		Specifier:	
Phone   Fax:		E-Mail:	
Design:	Concrete - May 14, 2026	Date:	5/14/2026
Fastening point:			

### 4 Shear load

	Load $V_{ua}$ [lb]	Capacity $\phi V_n$ [lb]	Utilization $\beta_v = V_{ua} / \phi V_n$	Status
Steel Strength*	N/A	N/A	N/A	N/A
Steel failure (with lever arm)*	N/A	N/A	N/A	N/A
Pryout Strength*	N/A	N/A	N/A	N/A
Concrete edge failure in direction **	N/A	N/A	N/A	N/A

\* highest loaded anchor    \*\*anchor group (relevant anchors)

### 5 Warnings

- The anchor design methods in PROFIS Engineering require rigid anchor plates per current regulations (EN1992-4, AS5216, etc.). This means load re-distribution on the anchors due to elastic deformations of the anchor plate are not considered - the anchor plate is assumed to be sufficiently stiff, in order not to be deformed when subjected to the design loading. PROFIS Engineering calculates the minimum required anchor plate thickness with FEM to limit the stress of the anchor plate based on the assumptions explained above. The proof if the rigid anchor plate assumption is valid is not carried out by PROFIS Engineering. Input data and results must be checked for agreement with the existing conditions and for plausibility!
- The equations presented in this report are based on imperial units. When inputs are displayed in metric units, the user should be aware that the equations remain in their imperial format.
- Condition A applies where the potential concrete failure surfaces are crossed by supplementary reinforcement proportioned to tie the potential concrete failure prism into the structural member. Condition B applies where such supplementary reinforcement is not provided, or where pullout or pryout strength governs.
- Refer to the manufacturer’s product literature for cleaning and installation instructions.
- For additional information about ACI 318 strength design provisions, please go to <https://viewer.joomag.com/profis-design-guide-us-en-summer-2021/0841849001625154758?short&/>
- Hilti post-installed anchors shall be installed in accordance with the Hilti Manufacturer’s Printed Installation Instructions (MPII). Reference ACI 318-19, Section 26.7.

**Fastening meets the design criteria!**



# Hilti PROFIS Engineering 3.1.31

www.hilti.com

Company:		Page:	6
Address:		Specifier:	
Phone   Fax:		E-Mail:	
Design:	Concrete - May 14, 2026	Date:	5/14/2026
Fastening point:			

## 6 Installation data

Profile: -  
Hole diameter in the fixture: -  
Plate thickness (input): -  
  
Drilling method: Hammer drilled  
Cleaning: Manual cleaning of the drilled hole according to instructions for use is required.

Anchor type and diameter: Kwik Bolt TZ2 - CS 1/2 (3 1/4)  
Item number: 2210255 KB-TZ2 1/2x4 1/2  
Maximum installation torque: 602 in.lb  
Hole diameter in the base material: 0.500 in.  
Hole depth in the base material: 4.250 in.  
Minimum thickness of the base material: 2.500 in.

Hilti Ø 1/2 in Kwik Bolt TZ2 - CS with 3.75 in nominal embedment depth per ICC-ES ESR-4266 , Hammer drill bit installation per MPII

### 6.1 Recommended accessories

Drilling	Cleaning	Setting
<ul style="list-style-type: none"> <li>• Suitable Rotary Hammer</li> <li>• Properly sized drill bit</li> </ul>	<ul style="list-style-type: none"> <li>• Manual blow-out pump</li> </ul>	<ul style="list-style-type: none"> <li>• Torque controlled cordless impact tool</li> <li>• Torque wrench</li> <li>• Hammer</li> </ul>

### Coordinates Anchor in.

Anchor	x	y	C <sub>-x</sub>	C <sub>+x</sub>	C <sub>-y</sub>	C <sub>+y</sub>
1	0.000	0.000	-	-	-	-



www.hilti.com

---

Company:		Page:	7
Address:		Specifier:	
Phone   Fax:		E-Mail:	
Design:	Concrete - May 14, 2026	Date:	5/14/2026
Fastening point:			

---

## 7 Remarks; Your Cooperation Duties

- Any and all information and data contained in the Software concern solely the use of Hilti products and are based on the principles, formulas and security regulations in accordance with Hilti's technical directions and operating, mounting and assembly instructions, etc., that must be strictly complied with by the user. All figures contained therein are average figures, and therefore use-specific tests are to be conducted prior to using the relevant Hilti product. The results of the calculations carried out by means of the Software are based essentially on the data you put in. Therefore, you bear the sole responsibility for the absence of errors, the completeness and the relevance of the data to be put in by you. Moreover, you bear sole responsibility for having the results of the calculation checked and cleared by an expert, particularly with regard to compliance with applicable norms and permits, prior to using them for your specific facility. The Software serves only as an aid to interpret norms and permits without any guarantee as to the absence of errors, the correctness and the relevance of the results or suitability for a specific application.
- You must take all necessary and reasonable steps to prevent or limit damage caused by the Software. In particular, you must arrange for the regular backup of programs and data and, if applicable, carry out the updates of the Software offered by Hilti on a regular basis. If you do not use the AutoUpdate function of the Software, you must ensure that you are using the current and thus up-to-date version of the Software in each case by carrying out manual updates via the Hilti Website. Hilti will not be liable for consequences, such as the recovery of lost or damaged data or programs, arising from a culpable breach of duty by you.