



Classified by  
Underwriters Laboratories, Inc.  
to UL 1479

## System No. W-J-2205

F Ratings - 1 and 2 Hr (See Item 3B)

T Rating - 0 Hr

L Rating At Ambient - 1.2 CFM/sq ft (See Item 3B)

L Rating At 400 F - Less Than 1 CFM/sq ft (See Item 3B)

WJ 2205

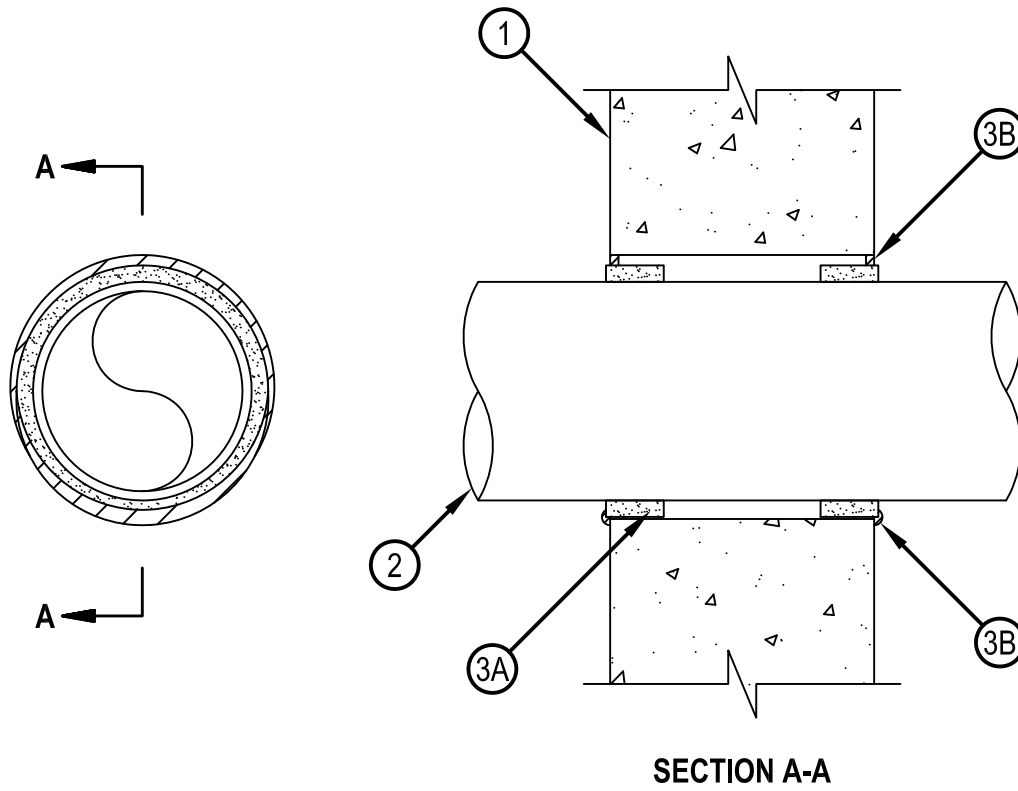

1. Wall Assembly — Min 6 in. (152 mm) thick reinforced lightweight or normal weight (100-150 pcf or 1600-2400 kg/m<sup>3</sup>) concrete. Wall may also be constructed of any UL Classified Concrete Blocks\*. See Table under Item 3B for max diam of opening. See Concrete Blocks (CAZT) category in the Fire Resistance Directory for names of manufacturers.
2. Through-Penetrants — One nonmetallic pipe installed within the firestop system. See Table under Item 3B for annular space required in the firestop system. Pipe to be rigidly supported on both sides of wall assembly. The following types and sizes of nonmetallic pipes may be used:
  - A. Polyvinyl Chloride (PVC) Pipe — Nom 6 in. (152 mm) diam (or smaller) Schedule 40 cellular or solid core PVC pipe for use in closed (process or supply) or vented (drain, waste or vent) piping system.
  - B. Chlorinated Polyvinyl Chloride (CPVC) Pipe — Nom 6 in. (152 mm) diam (or smaller) SDR 13.5 CPVC pipe for use in closed (process or supply) piping system.
  - C. Acrylonitrile Butadiene Styrene (ABS) Pipe — Nom 4 in. (102 mm) diam (or smaller) Schedule 40 cellular or solid core ABS pipe for use in closed (process or supply) or vented (drain, waste or vent) piping system.



**Hilti Firestop Systems**

Reproduced by HILTI, Inc. Courtesy of  
Underwriters Laboratories, Inc.

January 22, 2015

## System No. W-J-2205

3. Firestop System — The firestop system shall consist of the following:

A. Fill, Void or Cavity Material\* — Wrap Strip — See Table under Item 3B for min size of intumescent wrap strip. The wrap strip is continuously wrapped around the outer circumference of the pipe once and slid into the annular space such that approx 1/8 in. (3 mm) of the wrap strip protrudes from the wall surface. Wrap strip is held in place with integral fastening tape. Wrap strip installed on each surface of wall.

HILTI CONSTRUCTION CHEMICALS, DIV OF HILTI INC — CP 648S - 1.5" US, CP 648S - 2" US, CP 648S - 3" US, CP 648S - 4" US and CP 648S - 6" US

B. Fill, Void or Cavity Material\* — Caulk — Min 1/4 in. (6 mm) thickness of fill material applied within the annulus, flush with both surfaces of wall. For 2 hr fire-rated walls, 1/4 in. (6 mm) bead fill material also applied at wrap strip/wall interface. In 1 hr fire-rated walls, fill material is optional for nom 1-1/2, 2, 3 and 4 in. (38, 51, 76 and 102 mm) diam penetrants. In 2 hr fire-rated walls, fill material is optional for nom 1-1/2, 2 and 3 in. (38, 51 and 76 mm) diam penetrants. Fill material is required to be used to attain L Ratings.

HILTI CONSTRUCTION CHEMICALS, DIV OF HILTI INC — FS-One Sealant or FS-ONE MAX Intumescent Sealant.

Nom Pipe Diam, in. (mm)	Wrap Strip	Wrap Strip Size, thick. x width, in. (mm)	Max Diam of Opening, in. (mm)	Annular Space, in. (mm)	
				Min.	Max.
1-1/2 (38)	CP 648S - 1.5" US	3/16 x 1 (5 x 25)	2-3/8 (60)	3/16 (5)	5/16 (8)
2 (51)	CP 648S - 2" US	3/16 x 1 (5 x 25)	3 (76)	3/16 (5)	5/16 (8)
3 (76)	CP 648S - 3" US	3/16 x 1-3/4 (5 x 44)	4 (102)	3/16 (5)	5/16 (8)
4 (102)	CP 648S - 4" US	3/8 x 1-3/4 (10 x 44)	5-3/8 (137)	3/8 (10)	1/2 (13)
6 (152)	CP 648S - 6" US	1/2 x 1-3/4 (13 x 44)	8 (203)	9/16 (14)	13/16 (21)

\* Indicates such products shall bear the UL or cUL Certification Mark for jurisdictions employing the UL or cUL Certification (such as Canada), respectively.





Classified by  
Underwriters Laboratories, Inc.  
to UL 1479 and CAN/ULC-S115

# System No. W-J-7085

F Rating - 2 Hr  
T Rating - 1/2 Hr

WJ 7085

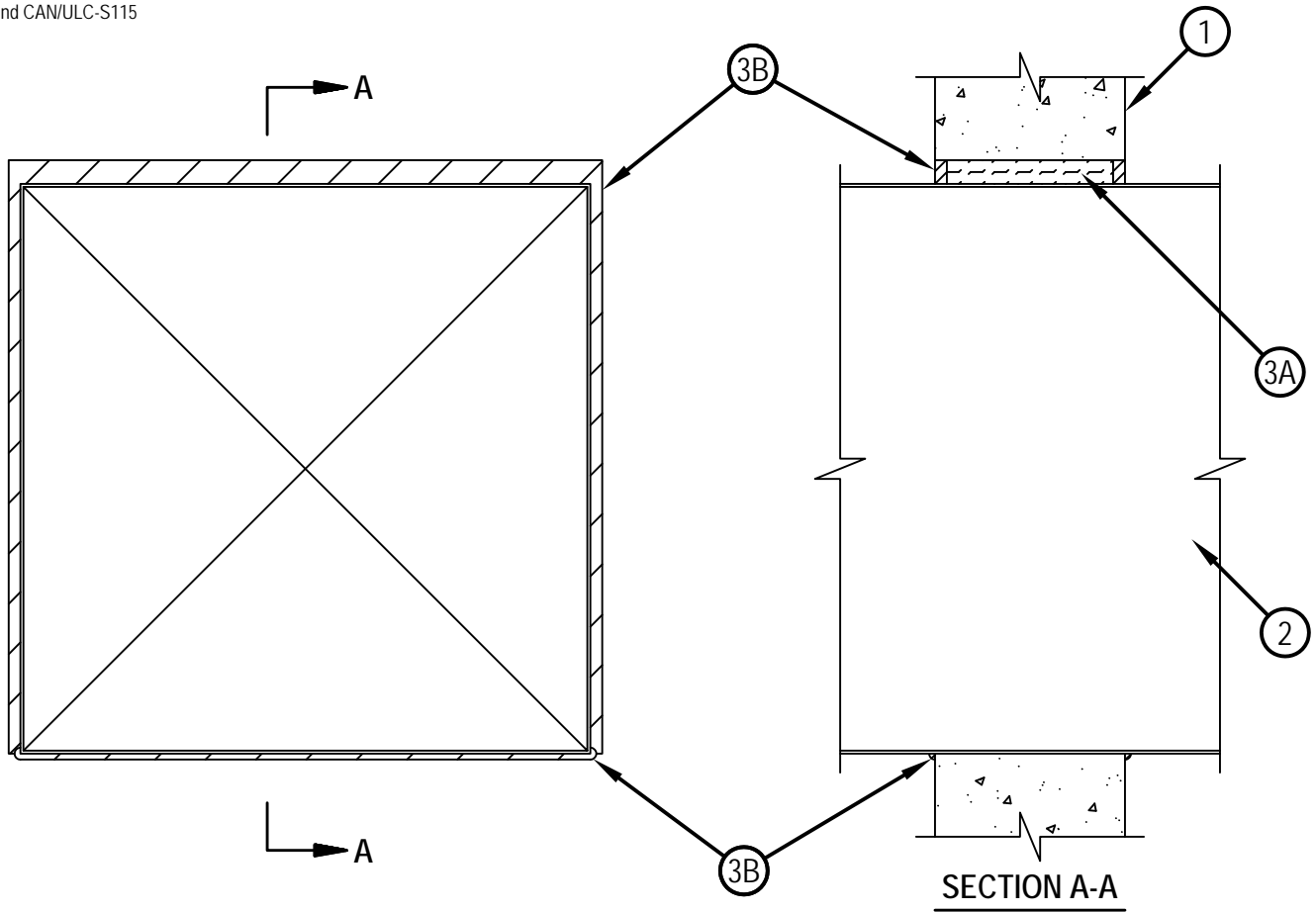

1. Wall Assembly — Min 6 in. (152 mm) thick reinforced lightweight or normal weight (100-150 pcf or 1600-2400 kg/m<sup>3</sup>) concrete. Wall may also be constructed of any UL Classified Concrete Blocks\*. Max size of opening is 625 sq in. (4032 cm<sup>2</sup>) with a max dimension of 25 in. (635 mm).

See Concrete Blocks (CAZT) category in the Fire Resistance Directory for names of manufacturers.

2. Steel Duct — Nom. 24 in. by 24 in. (610 by 610 mm) (or smaller) No. 24 gauge (or heavier) galv. steel duct to be installed within the firestop system. An annular space of min 1/2 in. (13 mm) to max 1 in. (25 mm) is required within the firestop system. As an option, the min annular space at the bottom of the duct may be 0 in. (point contact). Steel duct to be rigidly supported on both sides of wall assembly

3. Firestop System — The firestop system shall consist of the following:

A. Packing Material — Min 5 in. (127 mm) thickness of min 4 pcf (64 kg/m<sup>3</sup>) mineral wool batt insulation firmly packed into opening as a permanent form. Packing material to be recessed from both surfaces of wall to accommodate the required thickness of fill material.

B. Fill Void or Cavity Materials\* - Sealant — Min 1/2 in. (13 mm) thickness of sealant applied within annulus, flush with both surfaces of wall assembly. Min 1/4 in. (6 mm) diam bead of sealant shall be applied at the duct/concrete interface at any point contact location, on both surfaces of wall assembly.

HILTI CONSTRUCTION CHEMICALS, DIV OF  
HILTI INC — CP 606 Sealant

\*Bearing the UL Classification Mark



**Hilti Firestop Systems**

Reproduced by HILTI, Inc. Courtesy of  
Underwriters Laboratories, Inc.  
November 29, 2005



Classified by  
Underwriters Laboratories, Inc.  
to UL 1479 and CAN/ULC-S115

## System No. C-AJ-1372

F Rating -- 3 Hr

T Rating -- 0 Hr

L Rating At Ambient -- Less Than 1 CFM/sq ft

L Rating At 400 F -- 4 CFM/sq ft

CAJ 1372

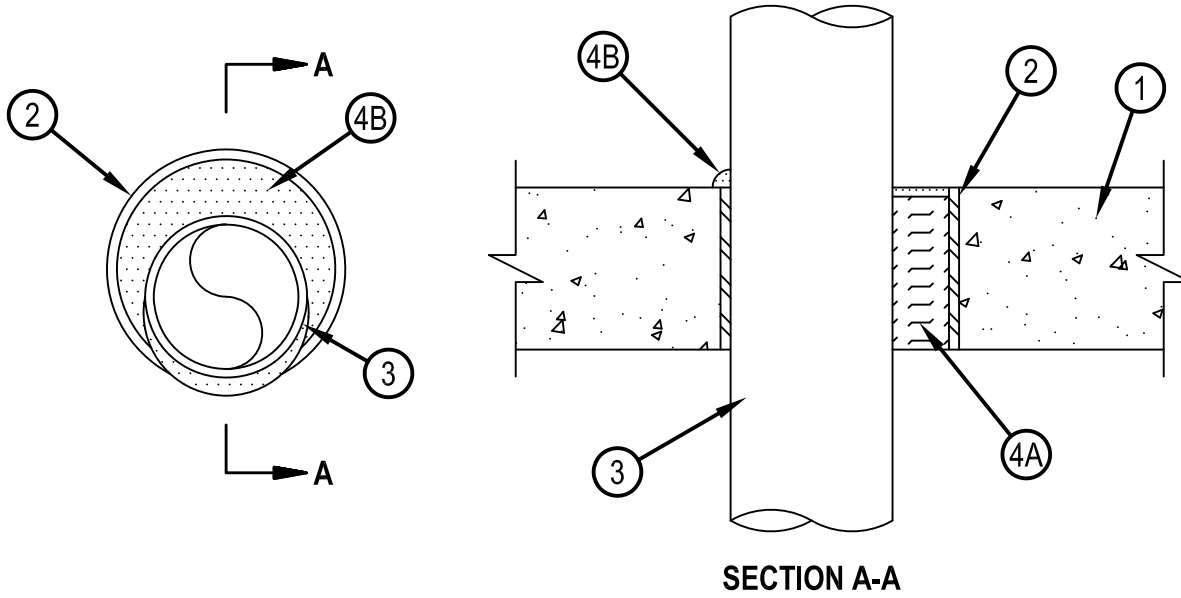

1. Floor or Wall Assembly — Min 4-1/2 in.(floors) or 4-3/4 in. thick (walls) reinforced lightweight or normal weight (100-150 pcf) concrete. Wall may also be constructed of any UL Classified Concrete Blocks\*. Max diam of opening is 10-1/2 in.  
See Concrete Blocks (CAZT) in the Fire Resistance Directory for names of manufacturers.
2. Metallic Sleeve — (Optional) Nom 10 in. diam (or smaller) Schedule 40 (or heavier) steel sleeve cast or grouted into floor or wall assembly, flush with both surfaces of floor or wall.
3. Through-Penetrant — One metallic pipe or conduit to be installed either concentrically or eccentrically within the firestop system. The annular space between pipe or conduit and periphery of opening shall be min 0 in. (point contact) to max 1-7/8. Pipe or conduit to be rigidly supported on both sides of floor assembly. The following types and sizes of metallic pipes or conduits may be used:
  - A. Steel Pipe — Nom 8 in. diam (or smaller) Schedule 10 (or heavier) steel pipe.
  - B. Cast Iron Pipe — Nom 8 in. diam (or smaller) cast or ductile iron pipe.
  - C. Copper Pipe — Nom 4 in. diam (or smaller) Regular (or heavier) copper pipe.
  - D. Copper Tubing — Nom 4 in. diam (or smaller) Type L (or heavier) copper tubing.
  - E. Conduit — Nom 4 in. diam (or smaller) steel conduit.
  - F. Conduit — Nom 4 in. (or smaller) steel electrical metallic tubing (EMT).
4. Firestop System — The firestop system shall consist of the following:
  - A. Packing Materials — Min 4-1/4 in. thickness of min 4 pcf mineral wool batt insulation firmly packed into opening as a permanent form. Packing material to be recessed from top surface of floor or both surfaces of wall to accommodate the required thickness of fill material.
  - B. Fill Void or Cavity Materials\* - Sealant — Min 1/4 in. thickness of fill material applied within annulus, flush with top surface of floor or both surfaces of wall. At point contact location between pipe and concrete, a min 1/4 in. diam bead of fill material shall be applied at the concrete/pipe interface on the top surface of the floor or both surfaces of wall.  
HILTI CONSTRUCTION CHEMICALS, DIV OF HILTI INC — CP 606 Flexible Firestop Sealant

\* Indicates such products shall bear the UL or cUL Certification Mark for jurisdictions employing the UL or cUL Certification (such as Canada), respectively.



**Hilti Firestop Systems**

Reproduced by HILTI, Inc. Courtesy of  
Underwriters Laboratories, Inc.  
January 30, 2019



Classified by  
Underwriters Laboratories, Inc.  
to UL 1479

## System No. C-AJ-2567

F Rating — 2 Hr

T Ratings — 0, 1-1/4 and 2 Hr (See Item 2)

L Rating At Ambient — Less Than 1 CFM/sq ft

L Rating At 400 F — 4 CFM/sq ft

W Rating — Class 1 (See Item 4C)

CAJ 2567

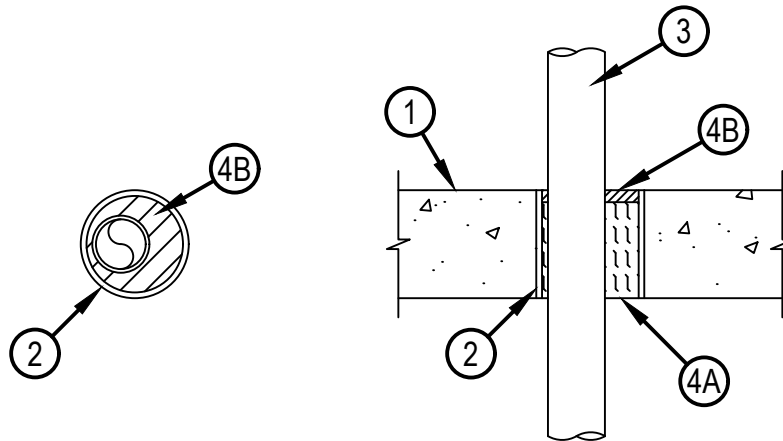

1. Floor or Wall Assembly — Min 4-1/2 in. (114 mm) thick reinforced lightweight or normal weight (100-150 pcf or 1600-2400 kg/m<sup>3</sup>) concrete floor or min 5 in. (127 mm) thick reinforced lightweight or normal weight (100-150 pcf or 1600-2400 kg/m<sup>3</sup>) concrete wall . Wall may also be constructed of any UL Classified Concrete Blocks\*. Floor may also be constructed of any 6 in. thick UL Classified hollow core Precast Concrete Units. Max diam of opening is 4 in. (102 mm).

See Concrete Blocks (CAZT) and Precast Concrete Units\* (CFTV) categories in the Fire Resistance Directory for names of manufacturers.

2. Steel Sleeve — (Optional) — Nom 4 in. (102 mm) diam (or smaller) Schedule 40 (or heavier) steel pipe cast or grouted into floor or wall assembly, flush with floor or wall surfaces or extend a max 3 in. (76 mm) above the floor or beyond both surfaces of the wall. The T Rating for the firestop system is 2 hr except that when the steel sleeve is provided. If the steel sleeve is installed flush with both surfaces of the floor or wall, the T Rating of the firestop system is 1-1/4 hr. If the steel sleeve extends beyond the top surface of the floor or both surfaces of the wall, the T Rating of the firestop system is 0 hr.



**Hilti Firestop Systems**

Reproduced by HILTI, Inc. Courtesy of  
Underwriters Laboratories, Inc.  
November 15, 2021

3. Through Penetrants — One nonmetallic pipe to be installed either concentrically or eccentrically within the firestop system. The annular space between pipe and sleeve (Item 2) shall be min 1/4 in. (6 mm) to max 1-3/8 in. (35 mm). When steel sleeve (Item 2) is not provided, the annular space between pipe and periphery of opening shall be min 0 in. (point contact) to max 1-5/8 in. (41 mm). Pipe to be rigidly supported on both sides of floor or wall assembly. The following types and sizes of nonmetallic pipes may be used:
- A. Polyvinyl Chloride (PVC) Pipe — Nom. 2 in. (51 mm) diam (or smaller) Schedule 40 solid-core or cellular core PVC pipe for use in closed (process or supply) or vented (drain, waste or vent) piping system.
  - B. Chlorinated Polyvinyl Chloride (CPVC) Pipe — Nom 2 in. (51 mm) diam (or smaller) SDR17 CPVC pipe for use in closed (process or supply) or vented (drain, waste or vent) piping systems.
  - C. Rigid Nonmetallic Conduit+ — Nom 2 in. (51 mm) diam (or smaller) Schedule 40 PVC conduit installed in accordance with Article 347 of the National Electrical Code (NFPA 70).
  - D. Crosslinked Polyethylene (PEX) Tubing — Nom 2 in. (51 mm) diam (or smaller) SDR 9 PEX tubing for use in closed (process or supply) piping systems.
  - E. Polypropylene (PP-R) Pipe — Nom 2 in. (63 mm OD) (or smaller) Aquatherm Greenpipe SDR 7.4 or 11 for use in closed (process or supply) piping systems.
  - F. Polypropylene (PP-RCT) Pipe — Nom 2 in. (63 mm OD) (or smaller) Aquatherm Bluepipe SDR 9, 11 or 17.6 for use in closed (process or supply) piping systems.
  - G. Polypropylene (PP-RCT) Pipe — Nom 2 in. (63 mm OD) (or smaller) Nupi Americas Niron pipe SDR 7.3, 11 or 17 for use in closed (process or supply) piping systems.
  - H. Polypropylene (PP-RCT) Pipe — Nom 2 in. (63 mm OD) (or smaller) Aquatechnik NA Fusion-Tech pipe SDR 7.4, 11 or 17.6 for use in closed (process or supply) piping systems.
  - I. Polypropylene (PP) Pipe — Nom 2 in. (63 mm OD) (or smaller) Uponor pipe SDR 9 or 11 for use in closed (process or supply) piping systems.
4. Firestop System — The firestop system shall consist of the following:
- A. Packing Material — Min 4 in. (102 mm) thickness of min 4 pcf (64 kg/m<sup>3</sup>) mineral wool batt insulation firmly packed into opening as a permanent form. Packing material to be recessed from top surface of floor or both surfaces of wall to accommodate the required thickness of fill material. When precast concrete units are used, packing material to be recessed from top surface of floor to accommodate the required thickness of fill material and to be installed flush with bottom surface of floor.
  - B. Fill, Void or Cavity Material\* — Sealant — Min 1/2 in. (13 mm) thickness of fill material applied within the annulus, flush with top surface of floor or both surfaces of wall assembly. Additionally, nom 1/2 in. (13 mm) bead of fill material applied between concrete and penetrant interface. When W Rating is required, the 1/2 in. (13 mm) depth of fill material shall be recessed min 1/4 in. (6 mm) below top surface of floor to accommodate additional sealant (Item 4C).  
HILTI CONSTRUCTION CHEMICALS, DIV OF HILTI INC — FS-ONE MAX Intumescent Sealant
  - C. Fill, Void or Cavity Material\* — Sealant — (Optional, Not Shown) — When min annular space is 3/16 in. (4.8 mm) and when the FS-One Sealant (Item 4B) is recessed 1/4 in. (6 mm) from the top surface of the floor, flush with top surface of floor, to attain the W Rating. W Rating applies only when CFS-S SIL GG or CFS-S SIL SL (floors only) Sealant is used.  
HILTI CONSTRUCTION CHEMICALS, DIV OF HILTI INC — CFS-S SIL GG or CFS-S SIL SL (floors only) Sealant

\* Indicates such products shall bear the UL or cUL Certification Mark for jurisdictions employing the UL or cUL Certification (such as Canada), respectively.





Classified by  
Underwriters Laboratories, Inc.  
to UL 1479 and CAN/ULC-S115

# System No. W-J-7091

WJ 7091

ANSI/UL1479 (ASTM E814)	CAN/ULC S115
F Rating - 2 Hr	F Rating - 2 Hr
T Rating - 0, 1, and 2 Hr (See Item 4C)	FT Rating - 0,1, and 2 Hr (See Item 4C)
	FH Rating - 2 Hr
	FTH Ratings - 0, 1, and 2 Hr (See Item 4C)

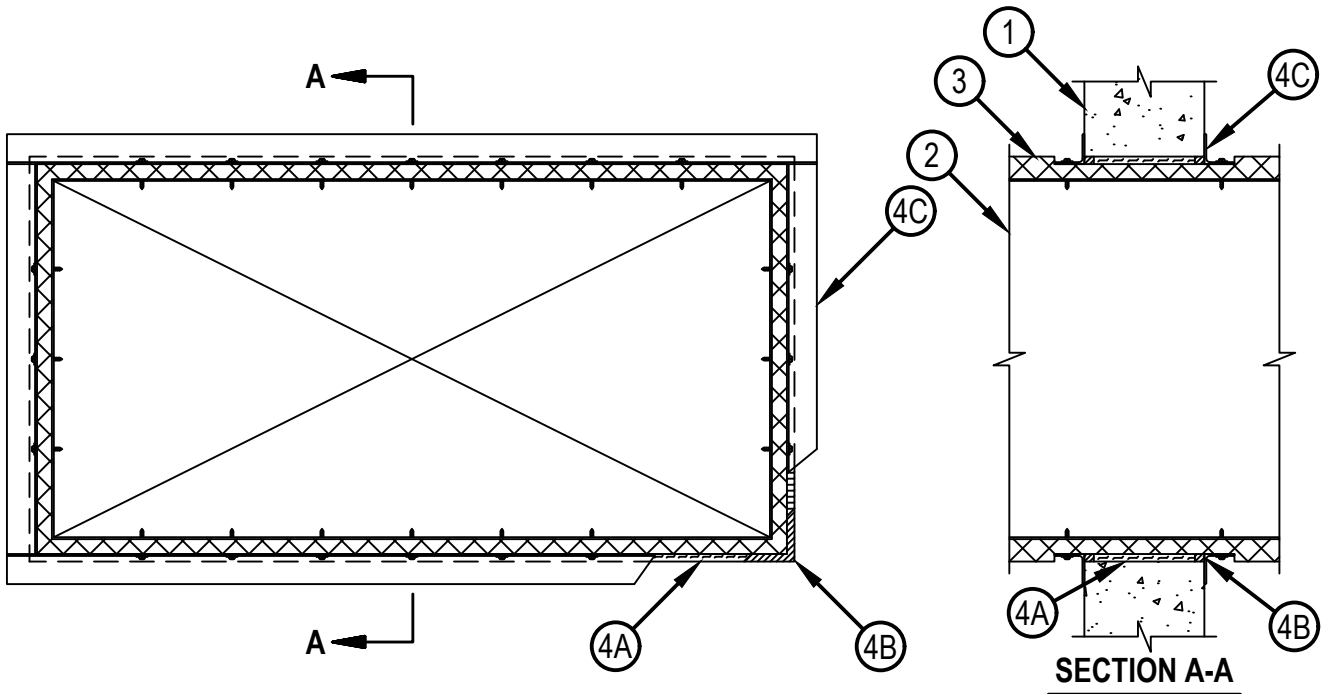

1. Wall Assembly — Min 6 in. (152 mm) thick reinforced lightweight or normal weight 100-150 pcf (1600-2400 kg/m<sup>3</sup>) concrete. Wall may also be constructed of any UL Classified Concrete Blocks\*. Max area of opening is 2457 in<sup>2</sup>. (1.58 m<sup>2</sup>) with the max length or width dimension of 63 in. (1600 mm).  
See Concrete Blocks (CAZT) category in the Fire Resistance Directory for names of manufacturers.
2. Steel Duct — Nom 36 in. by 60 in. (914 mm by 1524 mm or smaller) galv steel duct to be installed within the firestop system. The duct shall be constructed and reinforced in accordance with SMACNA construction standards. Duct to be rigidly supported on both sides of the wall assembly.
3. Batts and Blankets\* — Max 2 in. (51 mm) thick min 3/4 pcf (12 kg/m<sup>3</sup>) glass fiber batt or blanket jacketed on the outside with a foil-scrim-kraft facing. Longitudinal and transverse joints sealed with aluminum foil tape. During the installation of the fill material, the batt or blanket shall be compressed minimum 50% such that the annular space within the firestop system shall be min 1/4 in. (6 mm) to a max 3-1/2 in. (89 mm); refer to the table below.  
See Batts and Blankets - (BKNV) category in the Building Materials Directory for names of manufacturers. Any batt or blanket meeting the above specifications and bearing the UL Classification Marking with a Flame Spread Index of 25 or less and a Smoke Developed Index 50 or less may be used.



Reproduced by HILTI, Inc. Courtesy of  
Underwriters Laboratories, Inc.  
August 22, 2018

# System No. W-J-7091

WJ 7091

4. Firestop System — The firestop system shall consist of the following:

- A. Packing Material — Min 3-1/2 in. (89 mm) thickness of min 4.0 pcf (64 kg/m<sup>3</sup>) mineral wool batt insulation firmly packed into the opening as a permanent form. Packing material to be recessed from both sides of the wall to accommodate the required thickness of fill material.
- B. Fill, Void or Cavity Material\*—Sealant — Min 5/8 in. (16 mm) thickness of fill material applied within annulus flush with both surfaces of the wall.  
HILTI CONSTRUCTION CHEMICALS, DIV OF HILTI INC — FS-ONE MAX Intumescent Sealant
- C. Steel Retaining Angle — Min No. 18 MSG (1.2 mm) galv steel angles. When duct dimension exceeds 48 in. (1219 mm), angles shall be No. 16 MSG (or heavier). Angles cut to fit contour of duct with a 2 in. (51 mm) overlap on the duct and a min 1 in. (25 mm) overlap on the wall assembly on both surfaces of wall. 2 in. (51 mm) leg of angle secured to duct with min No. 8 by 3/4 in. (19 mm) long sheet metal screws, spaced a max of 6 in. (152 mm) OC. Angles are optional for ducts 30 in. (762 mm) by 24 in. (610 mm) and smaller. In addition, see table below for additional conditions and options regarding retaining angles.

Max Duct Dimension	Duct Thickness	Max Insulation Thickness (Item 3)	Annular Space	Packing Material (Item 4A) Required	Angle (Item 4C) Required	T-Rating Hr
**24 in. (610 mm)	24 ga or heavier	1-1/2 in (38 mm)	1/4 in. min to 1 in. max (6 to 25 mm)	No	No	0
25 in. (635mm) wide by 45 in (1143 mm) high	24 ga or heavier	2 in. (51mm)	1/4 in. min to 3-1/2 in. max (6. to 89 mm)	Yes	No	1 and 2 (Same as wall rating)

\*\* Indicated that when max 1-1/2 in. (38mm) thick insulation is used, steel angles are optional for those sides of the duct that do not exceed the dimension specified.

\* Indicates such products shall bear the UL or cUL Certification Mark for jurisdictions employing the UL or cUL Certification (such as Canada), respectively.



Reproduced by HILTI, Inc. Courtesy of Underwriters Laboratories, Inc.  
August 22, 2018



Classified by Underwriters Laboratories, Inc. to UL 1479 and CAN/ULC-S115

# System No. C-AJ-5090

CAJ 5090

ANSI/UL1479 (ASTM E814)	CAN/ULC S115
F Ratings — 2 and 3 Hr (See Item 4)	F Ratings — 2 and 3 Hr (See Item 4)
T Rating — 0 Hr	FT Rating — 0 Hr
L Rating At Ambient — 4 CFM/sq ft	FH Ratings — 2 and 3 Hr (See Item 4)
L Rating At 400 F — Less Than 1 CFM/sq ft	FTH Rating — 0 Hr
	L Rating At Ambient — 4 CFM/sq ft
	L Rating At 400 F — Less Than 1 CFM/sq ft

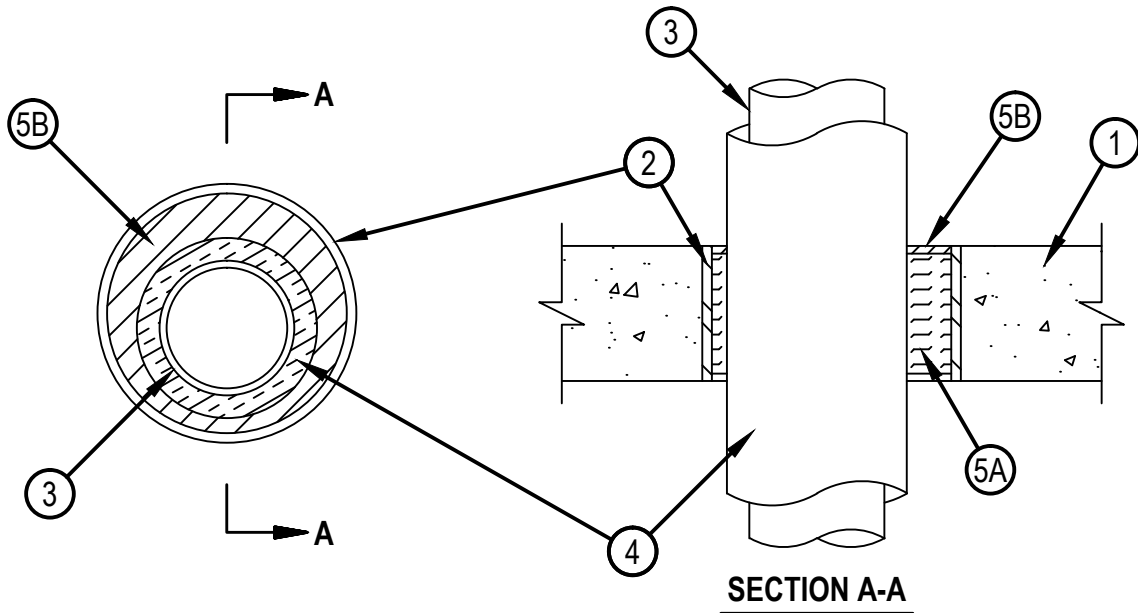

Reproduced by HILTI, Inc. Courtesy of Underwriters Laboratories, Inc. January 14, 2015

1. Floor or Wall Assembly — Min 4-1/2 in. (114 mm) thick reinforced lightweight or normal weight (100-150 pcf or 1600-2400 kg/m<sup>3</sup>) concrete. Wall may also be constructed of any UL Classified Concrete Blocks\*. Max diam of opening is 18 in. (457 mm).  
See Concrete Blocks (CAZT) Category in the Fire Resistance Directory for names of manufacturers.
2. Metallic Sleeve — (Optional) — Nom 18 in. (457 mm) diam (or smaller) Schedule 10 (or heavier) steel sleeve cast or grouted into floor or wall assembly, flush with floor or wall surfaces or extending a max of 3 in. (76 mm) above floor or beyond both surfaces of wall.
3. Through Penetrants — One metallic pipe or tubing to be centered within the firestop system. Pipe or tubing to be rigidly supported on both sides of floor or wall assembly. The following types and sizes of metallic pipes or tubing may be used:
  - A. Steel Pipe — Nom 4 in. (102 mm) diam (or smaller) Schedule 5 (or heavier) steel pipe.
  - B. Copper Pipe — Nom 4 in. (102 mm) diam (or smaller) Regular (or heavier) copper tubing.
  - C. Copper Tubing — Nom 4 in. (102 mm) diam (or smaller) Type L (or heavier) copper tubing.
4. Tube Insulation — Plastics+ — Min 1/2 in. (13 mm) to max 3/4 in. (19 mm) thick acrylonitrile butadiene/polyvinyl chloride (AB/PVC) flexible foam furnished in the form of tubing. Nom 1 in. (25 mm) thick AB/PVC flexible foam insulation may be used for max 2 hr F and FH Ratings when max 3 in. (76 mm) diam pipe or tubing is used. The annular space shall be min 1/2 in. (13 mm) to max 12 in. (305 mm). When max annular space exceeds 1-1/2 in. (38 mm) the F and FH Ratings are 2 hr.  
See Plastics+ (QMFZ2) Category in the Recognized Component Directory for names of manufacturers. Any Recognized Component tube insulation material meeting the above specifications and having a UL 94 Flammability Classification of 94-5VA may be used.
5. Firestop System — The firestop system shall consist of the following:
  - A. Packing Material — Min 4 in. (102 mm) thickness of min 4 pcf (64 kg/m<sup>3</sup>) mineral wool batt insulation firmly packed into opening as a permanent form. Packing material to be recessed from top surface of floor or from both surfaces of wall as required to accommodate the required thickness of fill material.
  - B. Fill, Void or Cavity Material\* — Sealant — Min 1/4 in. (6 mm) thickness of fill material applied within the annulus, flush with top surface of floor or with both surfaces of wall. When max annular space exceeds 1-1/2 in. (38 mm) the min thickness of fill material is 1/2 in. (13 mm).  
HILTI CONSTRUCTION CHEMICALS, DIV OF HILTI INC — FS-One Sealant or FS-ONE MAX Intumescent Sealant

\* Indicates such products shall bear the UL or cUL Certification Mark for jurisdictions employing the UL or cUL Certification (such as Canada), respectively.



**Hilti Firestop Systems**

Reproduced by HILTI, Inc. Courtesy of  
Underwriters Laboratories, Inc.  
January 14, 2015



Classified by  
Underwriters Laboratories, Inc.  
to UL 1479

## System No. W-J-5152

F Rating — 2 Hr

T Rating — 1-3/4 and 2 Hr (See Item 3)

WJ 5152

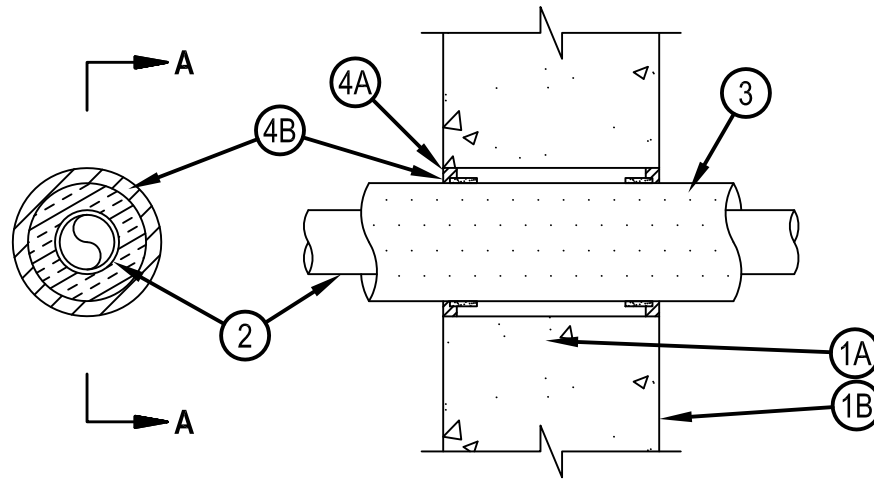

**SECTION A-A**

1. Wall Assembly — Min 6 in. (152 mm) thick reinforced lightweight or normal weight (100-150 pcf or 1600-2400 kg/m<sup>3</sup>) concrete. Wall may also be constructed of any UL Classified Concrete Blocks\*. Max diam of opening is 5-1/2 in. (140 mm).  
See Concrete Blocks (CAZT) category in the Fire Resistance Directory for names of manufacturers.
2. Through Penetrants — One Chlorinated Polyvinyl Chloride (CPVC) Pipe nonmetallic pipe to be installed concentrically or eccentrically within the firestop system. Nom 2 in. (51 mm) diam (or smaller) SDR 11 or SDR 13.5 CPVC pipe for use in closed (process or supply) piping systems. Pipe to be rigidly supported on both sides of the wall.
3. Pipe Covering\* — One of the following types of pipe coverings shall be used:
  - A. Pipe and Equipment Covering - Materials\* — Nom 1 in. (25 mm) thick hollow cylindrical heavy density (min 3.5 pcf) glass fiber units jacketed on the outside with an all service jacket. Longitudinal joints sealed with metal fasteners or factory-applied self-sealing lap tape. Transverse joints secured with metal fasteners or with butt tape supplied with the product. The annular space between the insulated pipe or tubing and periphery of the opening shall be min. 3/16 in. (4.8 mm) to max 15/16 in. (24 mm).  
See Pipe and Equipment Covering —Materials (BRGU) category in the Building Materials Directory for names of manufacturers. Any pipe covering material meeting the above specifications and bearing the UL Classification Marking with a Flame Spread Index of 25 or less and a Smoke Developed Index of 50 or less may be used.
  - B. Tube Insulation - Plastics+ — Nom 1 in. (19 mm) thick acrylonitrile butadiene/polyvinyl chloride (AB/PVC) flexible foam furnished in the form of tubing. The annular space between the insulated pipe or tubing and periphery of the opening shall be min. 3/16 in. (4.8 mm) to max 15/16 in. (24 mm).  
See Plastics (QMFZ2) category in the Plastics Recognized Component Directory for names of manufacturers. Any Recognized Component tube insulation material meeting the above specifications and having a UL 94 Flammability Classification of 95-5VA may be used.  
The hourly T, FT and FTH Ratings are 1-3/4 and 2 hr when 3B and 3A are used, respectively.
4. Firestop System — The firestop system shall consist of the following:
  - A. Fill, Void or Cavity Material\* — Wrap Strip — Nom 3/16 in. (5 mm) thick by 1 in. (25 mm) wide intumescent wrap strip. One layer wrapped around the pipe covering with the ends butted and held in place with tape. Wrap strip to be installed on each side of wall and recessed into opening 1/4 in. (6 mm) from each surface of wall.  
HILTI CONSTRUCTION CHEMICALS, DIV OF HILTI INC — CP-648E Wrap Strip
  - B. Fill, Void or Cavity Material\* — Sealant — Min 1/2 in. (13 mm) thickness of sealant applied within annulus, flush with both surfaces of wall. At area where wrap strip is installed, sealant thickness to be 1/4 in. (6 mm).  
HILTI CONSTRUCTION CHEMICALS, DIV OF HILTI INC — FS-ONE Sealant or FS-ONE MAX Intumescent Sealant

\* Indicates such products shall bear the UL or cUL Certification Mark for jurisdictions employing the UL or cUL Certification (such as Canada), respectively.

+Bearing the UL Recognized Mark



**Hilti Firestop Systems**

Reproduced by HILTI, Inc. Courtesy of  
Underwriters Laboratories, Inc.  
January 23, 2015



Classified by  
Underwriters Laboratories, Inc.  
to UL 1479

## System No. C-AJ-2335

F Rating -- 3 Hr

T Rating -- 2-3/4 and 3 Hr (See Item 3)

CAJ 2335

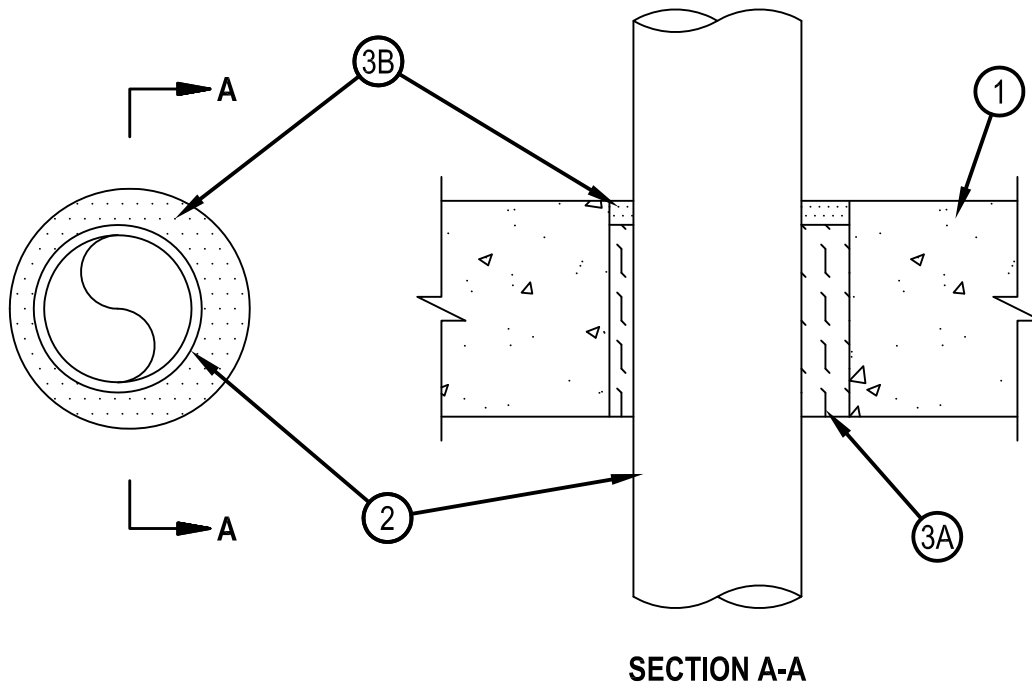

**SECTION A-A**

1. Floor or Wall Assembly — Min 4-1/2 in. (114 mm) thick reinforced lightweight or normal weight (100-150 pcf or 1600-2400 kg/m<sup>3</sup>) concrete or 5 in. thick reinforced lightweight or normal weight concrete wall. Wall may also be constructed of any UL Classified Concrete Blocks\*. Max diameter of opening is 5 in. (127 mm).

See Concrete Blocks (CAZT) category in the Fire Resistance Directory for names of manufactures.

2. Through Penetrants — One nonmetallic pipe or conduit to be installed concentrically or eccentrically within the firestop system. Annular space between pipe or conduit and edge of opening to be min 1/4 in. (6 mm) and max 1-1/4 in. (32 mm). Pipe or conduit to be rigidly supported on both sides of floor-ceiling assembly. The following types and sizes of nonmetallic pipes or conduit may be used:

A. Polyvinyl Chloride (PVC) Pipe — Nom 3 in. (76 mm) diam (or smaller) Schedule 40 solid or cellular core PVC for use in closed (process or supply) piping systems.

B. Chlorinated Polyvinyl Chloride (CPVC) Pipe — Nom 3 in. (76 mm) diam (or smaller) SDR13.5 CPVC for use in closed (process or supply) piping systems.

3. Firestop System — The firestop system shall consist of the following:

A. Packing Material — Min 4 in. (102 mm) thickness of min 4 pcf (64 kg/m<sup>3</sup>) mineral wool batt insulation firmly packed into opening as a permanent form. Packing material to be recessed from top surface of floor or both surfaces of wall to accommodate the required thickness of fill material.

B. Fill Void or Cavity Materials\* - Sealant — Min 1/2 in. (13 mm) thickness of fill material applied within the annulus, flush with top surface of floor or both surfaces of wall.

HILTI CONSTRUCTION CHEMICALS, DIV OF HILTI INC — FS-ONE Sealant or FS-ONE MAX Intumescent Sealant

The T Rating is 3 hr when the FS-ONE sealant is used and 2-3/4 hr when the FS\_ONE MAX sealant is used.

\* Indicates such products shall bear the UL or cUL Certification Mark for jurisdictions employing the UL or cUL Certification (such as Canada), respectively.



**Hilti Firestop Systems**

Reproduced by HILTI, Inc. Courtesy of  
Underwriters Laboratories, Inc.

January 09, 2015



Classified by Underwriters Laboratories, Inc. to UL 2079 and CAN/ULC-S115

# System No. HW-D-0268

HWD 0268

ANSI/UL2079	CAN/ULC S115
Assembly Ratings — 1, 2 and 3 Hr (See Item 3)	F Ratings — 1, 2 and 3 Hr (See Item 3)
Nominal Joint Width - 1 In.	FT Ratings — 1, 2 and 3 Hr (See Item 3)
Class II or III Movement Capabilities — 12.5% Compression or Extension	FH Ratings — 1, 2 and 3 Hr (See Item 3)
L Rating At Ambient — Less Than 1 CFM/ft	FTH Ratings — 1, 2 and 3 Hr (See Item 3)
L Rating At 400 F — Less Than 1 CFM/ft	Nominal Joint Width - 25 mm
	Class II or III Movement Capabilities — 12.5% Compression or Extension
	L Rating At Ambient — Less Than 1.5 L/s/m
	L Rating At 204 C — Less Than 1.5 L/s/m

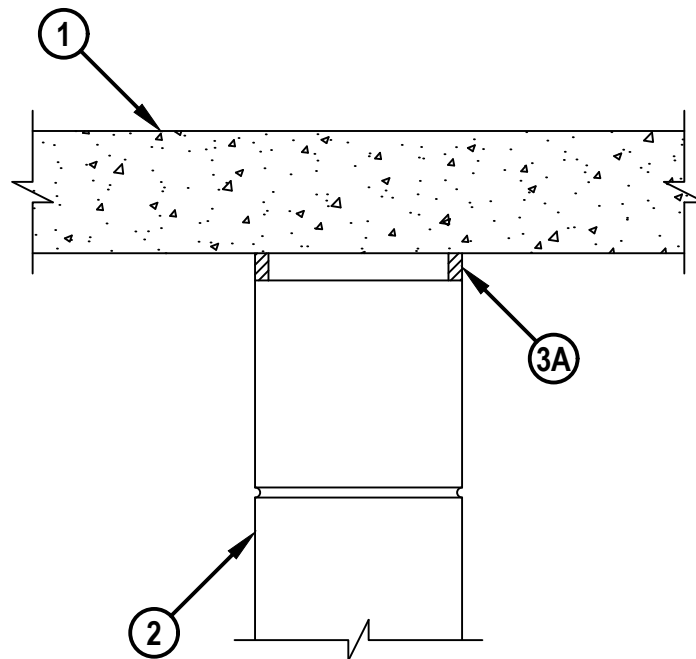

Reproduced by HILTI, Inc. Courtesy of Underwriters Laboratories, Inc. October 09, 2020

# System No. HW-D-0268

HWD 0268

1. Floor Assembly — Min 2-1/2 in. (64 mm) thick reinforced lightweight or normal weight (100-150 pcf or 1600-2400 kg/m<sup>3</sup>) structural concrete except that . min thickness of floor is 4-1/2 in. (114 mm) when concrete wall (Item 2) thickness is 4-1/2 in. (114 mm). Floor may also be constructed of any min 6 in. (152 mm) thick UL Classified hollow-core Precast Concrete Units\*.

See Precast Concrete Units (CFTV) category in the Fire Resistance Directory for names of manufacturers.

2. Wall Assembly — Min 8 in. (203 mm) thick steel reinforced lightweight or normal weight (100-150 pcf or 1600-2400 kg/m<sup>3</sup>) structural concrete. As an option, for assembly ratings of 1 and 2 hr, the wall may be min 4-1/2 in. (114 mm) thick steel reinforced lightweight or normal weight (100-150 pcf or 1600-2400 kg/m<sup>3</sup>) structural concrete. Wall may also be constructed of any UL Classified Concrete Blocks\*.

See Concrete Blocks (CAZT) category in the Fire Resistance Directory for names of manufacturers.

3. Joint System — Max separation between bottom of floor assembly and top of concrete wall at time of installation is 1 in. (25 mm). The joint system is designed to accommodate a max 12.5 percent compression or extension from its installed width. The joint system shall consists of the following:

A. Fill, Void or Cavity Material\* - Sealant — A min 1/4 in. (6 mm) or min 1/2 in. (13 mm) thickness of fill material installed within the joint, flush with each surface of the wall, as specified in Table below.

HILTI CONSTRUCTION CHEMICALS, DIV OF HILTI INC — CP606 Flexible Firestop Sealant

B. Forming Material — (Optional, Not Shown) - Mineral wool insulation or open or closed cell polyethylene or polyurethane foam backer rod. Forming material to be recessed from both surfaces of the wall as required to accommodate the required thickness of fill material.

Hourly Rating of Joint	Min Floor Thickness In. (mm)	Min Wall Thickness In. (mm)	Max Nom Joint Width In. (mm)	Min Sealant (Item 3A) Thickness In. (mm)	Forming Material (Item 3B)
1 and 2	4.5 (114)	4.5 (114)	1 (25)	1/4 (6)	Optional
3	2.5 (64)	8 (203)	1 (25)	1/2 (13)	Optional

\* Indicates such products shall bear the UL or cUL Certification Mark for jurisdictions employing the UL or cUL Certification (such as Canada), respectively.

