

Approval body for construction products
and types of construction

Bautechnisches Prüfamt

An institution established by the Federal and
Laender Governments



European Technical Assessment

ETA-98/0001
of 20 July 2023

English translation prepared by DIBt - Original version in German language

General Part

Technical Assessment Body issuing the
European Technical Assessment:

Deutsches Institut für Bautechnik

Trade name of the construction product

Hilti metal expansion anchor HST, HST-R, HST-HCR,
HST3, HST3-R

Product family
to which the construction product belongs

Mechanical fastener for use in concrete

Manufacturer

Hilti AG
BU Anchors
Feldkircherstraße 100
9494 SCHAAN
FÜRSTENTUM LIECHTENSTEIN

Manufacturing plant

Hilti Werke

This European Technical Assessment
contains

67 pages including 3 annexes which form an integral part
of this assessment

This European Technical Assessment is
issued in accordance with Regulation (EU)
No 305/2011, on the basis of

EAD 330232-01-0601, Edition 05/2021

This version replaces

ETA-98/0001 issued on 3 November 2022

The European Technical Assessment is issued by the Technical Assessment Body in its official language. Translations of this European Technical Assessment in other languages shall fully correspond to the original issued document and shall be identified as such.

Communication of this European Technical Assessment, including transmission by electronic means, shall be in full. However, partial reproduction may only be made with the written consent of the issuing Technical Assessment Body. Any partial reproduction shall be identified as such.

This European Technical Assessment may be withdrawn by the issuing Technical Assessment Body, in particular pursuant to information by the Commission in accordance with Article 25(3) of Regulation (EU) No 305/2011.

Specific Part

1 Technical description of the product

The Hilti metal expansion anchor HST, HST-R, HST-HCR, HST3 and HST3-R is an anchor made of galvanized steel (HST, HST3), stainless steel (HST-R, HST3-R) or high corrosion resistant steel (HST-HCR) which is placed into a drilled hole and anchored by torque-controlled expansion.

The product description is given in Annex A.

2 Specification of the intended use in accordance with the applicable European Assessment Document

The performances given in Section 3 are only valid if the anchor is used in compliance with the specifications and conditions given in Annex B.

The verifications and assessment methods on which this European Technical Assessment is based lead to the assumption of a working life of the anchor of at least 50 years. The indications given on the working life cannot be interpreted as a guarantee given by the producer, but are to be regarded only as a means for choosing the right products in relation to the expected economically reasonable working life of the works.

3 Performance of the product and references to the methods used for its assessment

3.1 Mechanical resistance and stability (BWR 1)

Essential characteristic	Performance
Characteristic resistance to tension load (static and quasi-static loading) Method A	See Annex B8 to B13, C1 to C4
Characteristic resistance to shear load (static and quasi-static loading)	See Annex C5 to C8
Displacements	See Annex C9 to C12
Characteristic resistance and displacements for seismic performance category C1 and C2	See Annex C13 to C25

3.2 Safety in case of fire (BWR 2)

Essential characteristic	Performance
Reaction to fire	Class A1
Resistance to fire	See Annex C26 to C35

3.3 Aspects of durability linked with the Basic Works Requirements

Essential characteristic	Performance
Durability	See Annex B1

4 Assessment and verification of constancy of performance (AVCP) system applied, with reference to its legal base

In accordance with the European Assessment Document EAD 330232-01-0601 the applicable European legal act is: [96/582/EC].

The system to be applied is: 1

5 Technical details necessary for the implementation of the AVCP system, as provided for in the applicable EAD

Technical details necessary for the implementation of the AVCP system are laid down in the control plan deposited with Deutsches Institut für Bautechnik.

Issued in Berlin on 20 July 2023 by Deutsches Institut für Bautechnik

Dipl.-Ing. Beatrix Wittstock
Head of Section

beglaubigt:
Ziegler

Installed condition

Figure A1:

Hilti metal expansion anchor HST, HST-R and HST-HCR

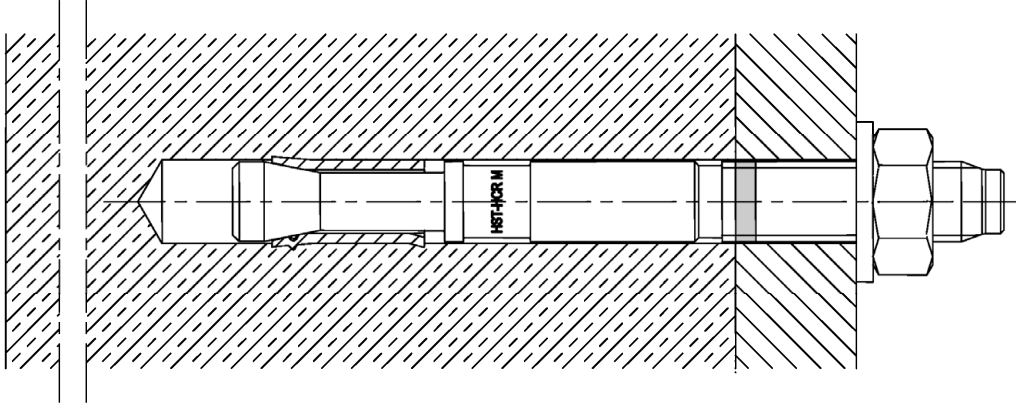
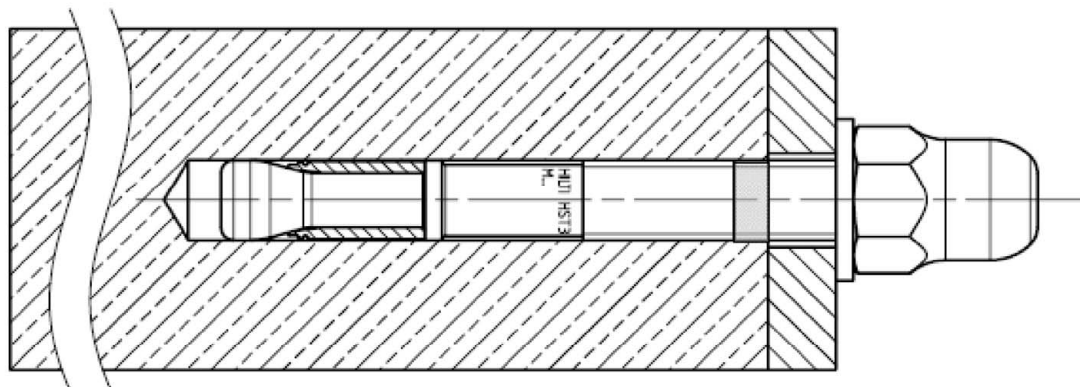
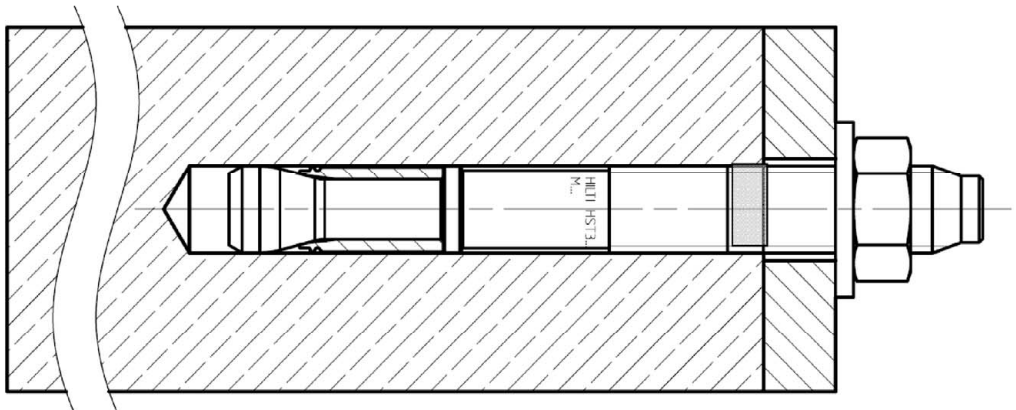

Figure A2:

Hilti metal expansion anchor HST3 and HST3-R with standard hexagon nut respectively optional dome nut



Hilti metal expansion anchor HST, HST-R, HST-HCR, HST3, HST3-R

Product description
Installed condition

Annex A1

Figure A3:

Hilti metal expansion anchor HST3 and HST3-R with Filling Set and standard hexagon nut respectively optional dome nut

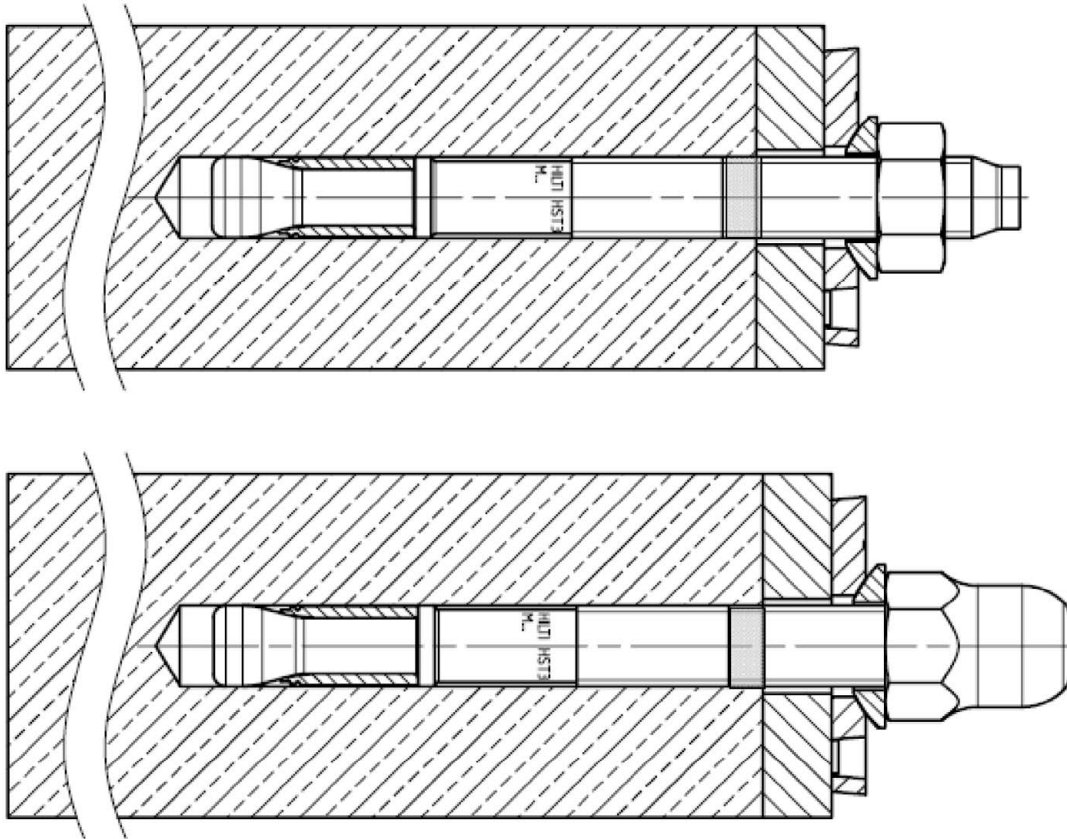

Hilti metal expansion anchor HST, HST-R, HST-HCR, HST3, HST3-R

Product description
Installed condition

Annex A2

Product description: Hilti metal expansion anchor HST, HST-R and HST-HCR

Cold-formed version

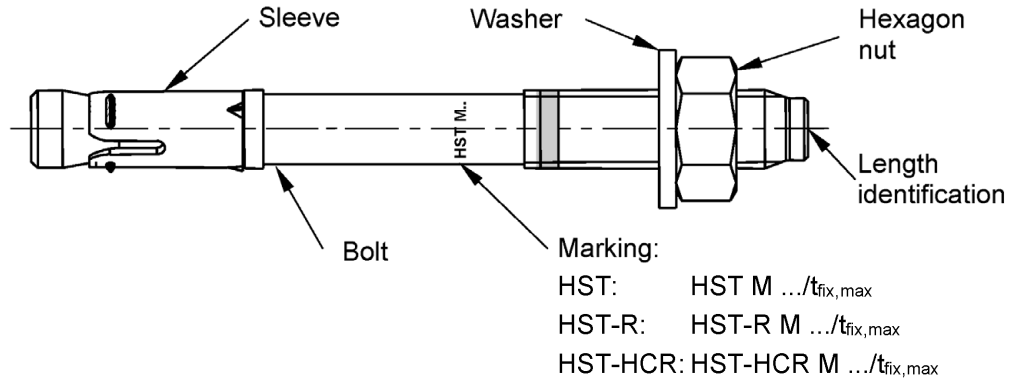

Machined version

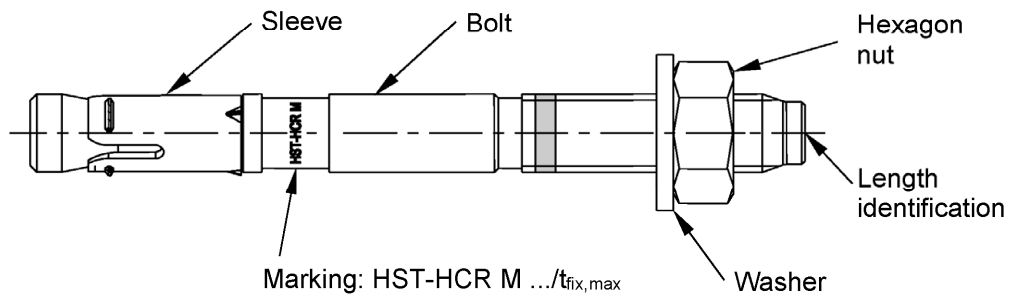

Hilti metal expansion anchor HST, HST-R, HST-HCR, HST3, HST3-R

Product description
Anchor types, marking and identification

Annex A3

Product description: Hilti metal expansion anchor HST3 and HST3-R

Cold-formed version

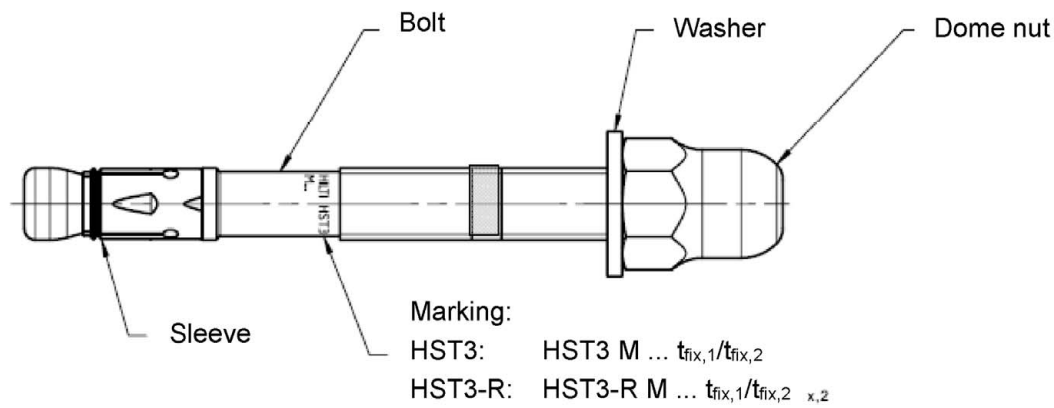
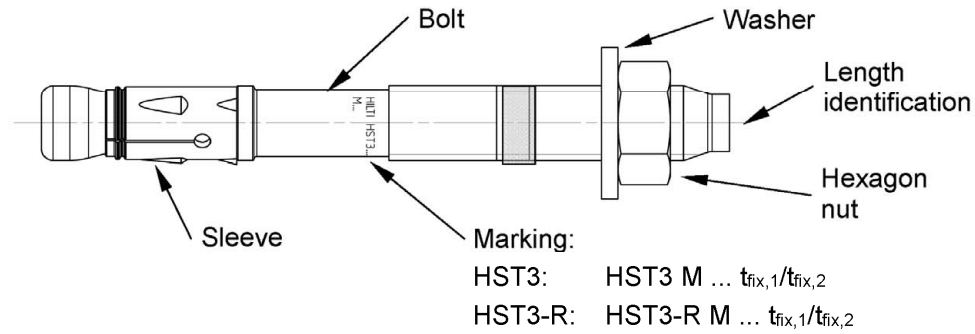

Hilti metal expansion anchor HST, HST-R, HST-HCR, HST3, HST3-R

Product description
Anchor types, marking and identification

Annex A4

Machined version M8 - M16

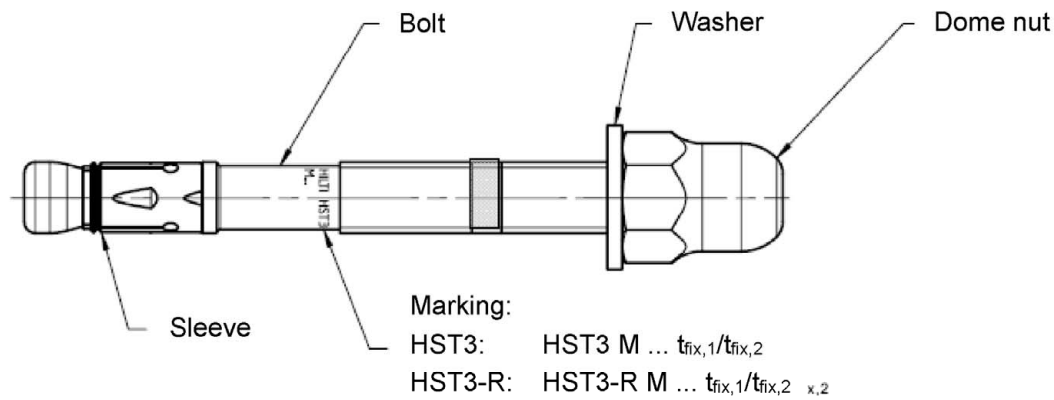
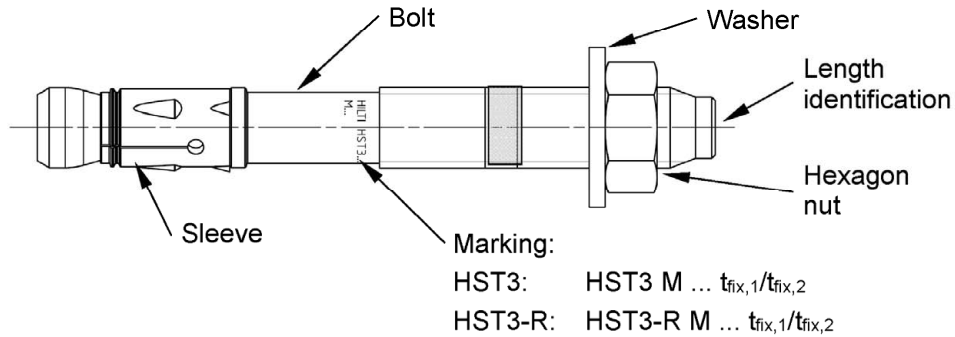

Machined version M20 - M24

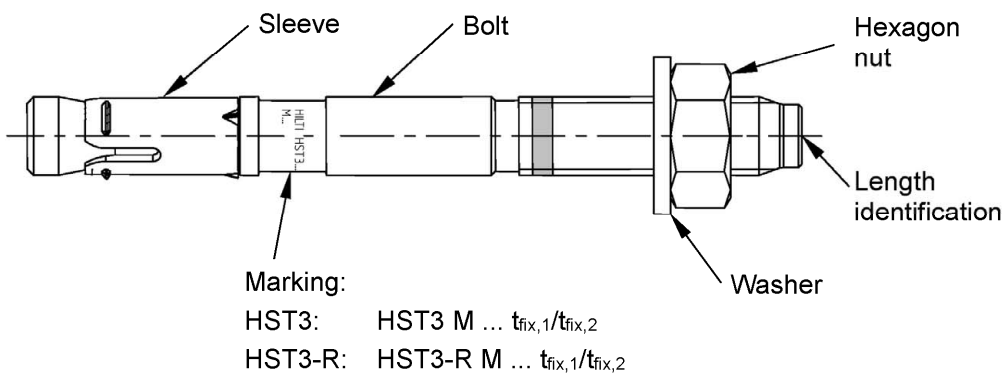

Hilti metal expansion anchor HST, HST-R, HST-HCR, HST3, HST3-R

Product description
Anchor types, marking and identification

Annex A5

Table A1: Length identification HST, HST3, HST-R, HST3-R, HST-HCR

Letter		A	B	C	D	E	f	II
Anchor length	≥ [mm]	38,1	50,8	63,5	76,2	88,9	100,0	100,0
	< [mm]	50,8	63,5	76,2	88,9	101,6	100,0	100,0

Letter		F	G	Δ	H	I	J	K
Anchor length	≥ [mm]	101,6	114,3	125,0	127,0	139,7	152,4	165,1
	< [mm]	114,3	127,0	125,0	139,7	152,4	165,1	177,8

Letter		L	M	N	O	P	Q	R
Anchor length	≥ [mm]	177,8	190,5	203,2	215,9	228,6	241,3	254,0
	< [mm]	190,5	203,2	215,9	228,6	241,3	254,0	279,4

Letter		r	S	T	U	V	W	X
Anchor length	≥ [mm]	260,0	279,4	304,8	330,2	355,6	381,0	406,4
	< [mm]	260,0	304,8	330,2	355,6	381,0	406,4	431,8

Letter		Y	Z	AA	BB	CC	DD	EE
Anchor length	≥ [mm]	431,8	457,2	482,6	508,0	533,4	558,8	584,2
	< [mm]	457,2	482,6	508,0	533,4	558,8	584,2	609,6

Letter		FF	GG	HH	II	JJ	KK	LL
Anchor length	≥ [mm]	609,6	635,0	660,4	685,8	711,2	736,6	762,0
	< [mm]	635,0	660,4	685,8	711,2	736,6	762,0	787,4

Letter		MM	NN	OO	PP	QQ	RR	SS
Anchor length	≥ [mm]	787,4	812,8	838,2	863,6	889,0	914,4	939,8
	< [mm]	812,8	838,2	863,6	889,0	914,4	939,8	965,2

Letter		TT	UU	VV
Anchor length	≥ [mm]	965,2	990,6	1016,0
	< [mm]	990,6	1016,0	1041,4

Hilti metal expansion anchor HST, HST-R, HST-HCR, HST3, HST3-R

Product description
Length identification

Annex A6

Table A2: Materials

Designation	Material
HST (Carbon steel)	
Expansion sleeve	Stainless steel A4 according to EN 10088-1:2014
Bolt	Carbon steel, galvanized, coated (transparent), rupture elongation ($l_0 = 5d$) > 8 %
Washer	Carbon steel, galvanized
Hexagon nut	Carbon steel, galvanized
Filling Set (Carbon steel)	
Sealing washer	Carbon steel, galvanized
Spherical washer	Carbon steel, galvanized
HST-R (Stainless steel) Corrosion resistance class III according EN 1993-1-4:2006+A1:2015	
Expansion sleeve	Stainless steel A4 according to EN 10088-1:2014
Bolt	Stainless steel A4 according to EN 10088-1:2014, cone coated (red or transparent), rupture elongation ($l_0 = 5d$) > 8 %
Washer	Stainless steel A4 according to DIN EN ISO 3506-1:2010
Hexagon nut	Stainless steel A4 according to DIN EN ISO 3506-2:2010, coated
Filling Set (Stainless steel) Corrosion resistance class III according EN 1993-1-4:2006+A1:2015	
Sealing washer	Stainless steel A4 according to ASTM A 240/A 240M:2019
Spherical washer	Stainless steel A4 according to EN 10088-1:2014
HST-HCR (High corrosion resistance steel) Corrosion resistance class V according EN 1993-1-4:2006+A1:2015	
Expansion sleeve	Stainless steel A4 according to EN 10088-1:2014
Bolt	High corrosion resistance steel according to EN 10088-1:2014, cone coated (red), rupture elongation ($l_0 = 5d$) > 8 %
Washer	High corrosion resistance steel according to EN 10088-1:2014
Hexagon nut	High corrosion resistance steel according to EN 10088-1:2014, coated

Hilti metal expansion anchor HST, HST-R, HST-HCR, HST3, HST3-R

Product description
Materials

Annex A7

Table A2 continued

Designation	Material
HST3 (Carbon steel)	
Expansion sleeve	M10, M16: Carbon steel, galvanized or stainless steel according to EN 10088-1:2014 M8, M12, M20, M24: Stainless steel according to EN 10088-1:2014
Bolt	Carbon steel, galvanized, coated (transparent), rupture elongation ($l_0 = 5d$) > 8 %
Washer	Carbon steel, galvanized
Hexagon nut Dome nut	Carbon steel, galvanized
Filling Set (Carbon steel)	
Sealing washer	Carbon steel, galvanized
Spherical washer	Carbon steel, galvanized
HST3-R (Stainless steel) Corrosion resistance class III according EN 1993-1-4:2006+A1:2015	
Expansion sleeve	Stainless steel A4 according to EN 10088-1:2014
Bolt	Stainless steel A4 according to EN 10088-1:2014, cone coated (transparent), rupture elongation ($l_0 = 5d$) > 8 %
Washer	Stainless steel A4 according to DIN EN ISO 3506-1:2010
Hexagon nut Dome nut	Stainless steel A4 according to DIN EN ISO 3506-2:2010, coated
Filling Set (Stainless steel) Corrosion resistance class III according EN 1993-1-4:2006+A1:2015	
Sealing washer	Stainless steel A4 according to ASTM A 240/A 240M:2019
Spherical washer	Stainless steel A4 according to EN 10088-1:2014

Hilti metal expansion anchor HST, HST-R, HST-HCR, HST3, HST3-R

Product description
Materials

Annex A8

Injection mortar Hilti HIT-HY 200-A

Hybrid system with resin, hardener, cement and water
Foil pack 330 ml and 500 ml

Marking:
HILTI HIT
Production number and
production line
Expiry date mm/yyyy



Product name: "Hilti HIT-HY 200-A"

Static mixer Hilti HIT-RE-M



Dispensers



Hilti HDM 330



Hilti HDE 500

Table A3: curing time Hilti HIT-HY 200-A

Temperature of base material / environment	Curing time t_{cure} Hilti HIT-HY 200-A
-10 °C to -5 °C	7 hours
-4 °C to 0 °C	4 hours
1 °C to 5 °C	2 hours
6 °C to 10 °C	75 minutes
11 °C to 20 °C	45 minutes
21 °C to 30 °C	30 minutes
31 °C to 40 °C	30 minutes

Hilti metal expansion anchor HST, HST-R, HST-HCR, HST3, HST3-R

Product description
Injection mortar

Annex A9

Table A4: Dimensions HST, HST-R and HST-HCR

HST, HST-R, HST-HCR			M8	M10	M12	M16	M20 ¹⁾	M24 ¹⁾
Maximum length of anchor	$l_{\max} \leq$	[mm]	260	280	295	350	450	500
Shaft diameter at the cone	d_R	[mm]	5,5	7,2	8,5	11,6	14,6	17,4
Length of expansion sleeve	l_s	[mm]	14,8	18,2	22,7	24,3	28,3	36,0

¹⁾ Only HST and HST-R

HST, HST-R and HST-HCR

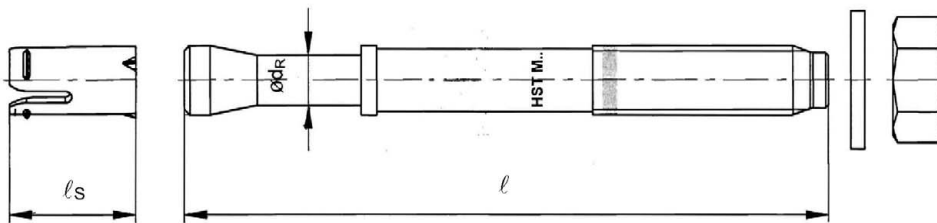
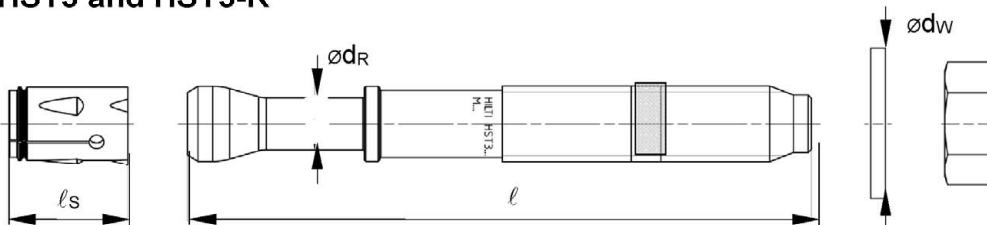

Table A5: Dimensions HST3 and HST3-R

HST3, HST3-R			M8	M10	M12	M16	M20	M24
Maximum length of anchor	$l_{\max} \leq$	[mm]	260	280	350	475	450	500
Shaft diameter at the cone	d_R	[mm]	5,60	6,94	8,22	11,00	14,62	17,4
Length of expansion sleeve	l_s	[mm]	13,6	16,0	20,0	25,0	28,3	36,0
Diameter of washer	$d_w \geq$	[mm]	15,57	19,48	23,48	29,48	36,38	43,38

HST3 and HST3-R



Hilti metal expansion anchor HST, HST-R, HST-HCR, HST3, HST3-R

Product description
Dimensions

Annex A10

Filling Set to fill the annular gap between anchor and fixture

Table A6: Dimensions Filling Set

Filling Set used for HST, HST-R, HST3, HST3-R			M8	M10	M12	M16	M20
Diameter of sealing washer	d_{vs}	[mm]	38	42	44	52	60
Thickness of sealing washer	h_{vs}	[mm]	5			6	

Sealing washer

Spherical washer

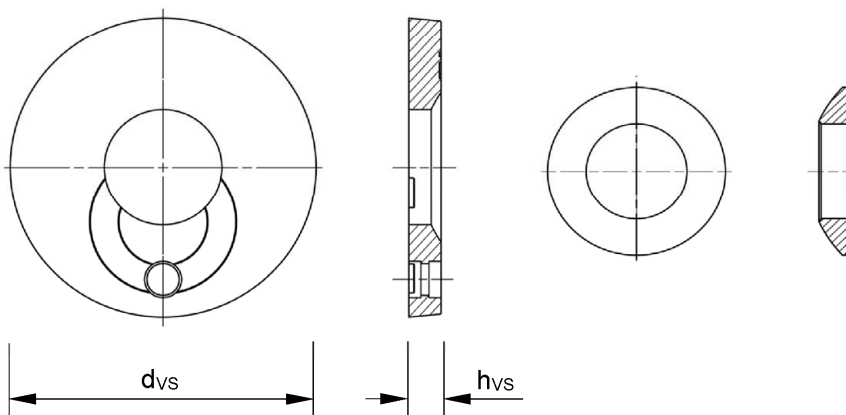

Dome nut

Table A7: Dimensions Dome nut

Dome nut used for HST3, HST3-R			M8	M10	M12	M16
Length of thread	$L_{\text{thread}} \geq$	[mm]	13,3	16,8	17,8	22,3
Length of nut	$L_{\text{DN}} \geq$	[mm]	18,1	21,9	24,0	29,5

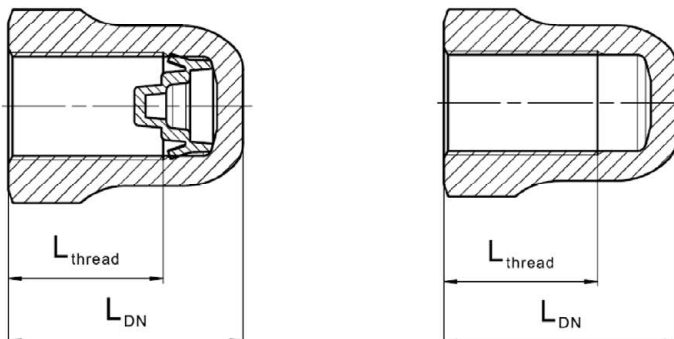

Hilti metal expansion anchor HST, HST-R, HST-HCR, HST3, HST3-R

Product description
Dimensions

Annex A11

Specifications of intended use

Base materials:

- Compacted reinforced or unreinforced normal weight concrete without fibres according to EN 206-1:2013 + A1:2016.
- Strength classes C20/25 to C50/60 according to EN 206-1:2013 + A1:2016.
- Cracked and uncracked concrete

Use conditions (Environmental conditions):

- Structures subject to dry internal conditions (all materials)
- For all other conditions according EN 1993-1-4:2006 + A1:2015 corresponding to corrosion resistance classes Annex A7 und A8 Table A2 (stainless steels).

Design:

- Anchorages are designed under the responsibility of an engineer experienced in anchorages and concrete work.
- Verifiable calculation notes and drawings are prepared taking account of the loads to be anchored. The position of the anchor is indicated on the design drawings (e. g. position of the anchor relative to reinforcement or to supports, etc.).
- Anchorages are designed in accordance with:
EN 1992-4:2018 and EOTA Technical Report TR 055, 12/2016
- In case of requirements to resistance to fire local spalling of the concrete cover must be avoided.

Installation:

- Anchor installation carried out by appropriately qualified personnel and under the supervision of the person responsible for technical matters of the site.
- The anchor may only be set once.
- Overhead applications are permitted.

Hilti metal expansion anchor HST, HST-R, HST-HCR, HST3, HST3-R

Intended use
Specifications

Annex B1

Table B1: Drilling technique HST, HST-R and HST-HCR

HST, HST-R and HST-HCR	M8	M10	M12	M16	M20 ¹⁾	M24 ¹⁾
Hammer drilling (HD) 	✓	✓	✓	✓	✓	✓

¹⁾ Only HST and HST-R

Table B2: Drilling technique HST3 and HST3-R







HST3, HST3-R	M8	M10	M12	M16	M20	M24
Hammer drilling (HD) 	✓	✓	✓	✓	✓	✓
Diamond coring (DD) with <ul style="list-style-type: none"> DD EC-1 coring tool and DD-C ... TS/TL core bits or DD-C ... T2/T4 core bits DD 30-W coring tool and C+ ... SPX-T (abrasive) core bits 	✓	✓	✓	✓	✓	✓
Hammer drilling with Hilti hollow drill bit TE-CD/YD ... drilling system (HDB) 	-	-	✓	✓	✓	✓

Table B3: Drill hole cleaning

Manual cleaning (MC): Hilti hand pump for blowing out boreholes	
Compressed air cleaning (CAC): Air nozzle with an orifice opening of 3,5 mm in diameter	
Automated cleaning (AC): Cleaning is performed during drilling with Hilti TE-CD and TE-YD drilling system including vacuum cleaner	

Hilti metal expansion anchor HST, HST-R, HST-HCR, HST3, HST3-R

Intended use
Specifications



Annex B2

Table B4: Methods for application of torque moment HST, HST-R and HST-HCR

HST, HST-R and HST-HCR	M8	M10	M12	M16	M20 ¹⁾	M24 ¹⁾
Torque wrench 	✓	✓	✓	✓	✓	✓

¹⁾ Only HST and HST-R

Table B5: Methods for application of torque moment HST3 and HST3-R

HST3, HST3-R	M8	M10	M12	M16	M20	M24
Torque wrench 	✓	✓	✓	✓	✓	✓
Machine torquing with Hilti SIW impact wrench and SI-AT adaptive torque module 						
<ul style="list-style-type: none"> SIW 4AT-22 with SI-AT-22¹⁾ 	✓	✓	✓	✓	-	-
<ul style="list-style-type: none"> SIW 6AT-22 with SI-AT-22¹⁾ 	-	✓	✓	✓	✓	✓

¹⁾ Equivalent combination of Hilti SIW + SI-AT tool, compatible to this anchor type, may be used

Table B6: Overview use and performance categories HST, HST-R and HST-HCR

Anchorage subject to:	HST, HST-R, HST-HCR
Static and quasi static loading	M8 to M24 (HST and HST-R) M8 to M16 (HST-HCR) Table : C1, C3, C5
Seismic performance category C1/C2	M10 to M16 (HST and HST-R) Table : C7, C9, C11, C12, C15, C16
Static and quasi static loading under fire exposure	M8 to M24 Table : C19, C21

Table B7: Overview use and performance categories HST3 and HST3-R

Anchorage subject to:	HST3, HST3-R
Static and quasi static loading	M10 to M16 (for $h_{ef,1}$) M8 to M24 (for $h_{ef,2}$) Table : C2, C4, C6
Seismic performance category C1/C2	M8 to M20 (for $h_{ef,2}$) M12 (for $h_{ef,1}$) Table : C8, C10, C13, C14, C17, C18
Static and quasi static loading under fire exposure	M10 to M16 (for $h_{ef,1}$) M8 to M24 (for $h_{ef,2}$) Table : C20, C22

Hilti metal expansion anchor HST, HST-R, HST-HCR, HST3, HST3-R

Intended use
Specifications

Annex B3

Table B8: Installation parameters for HST, HST-R and HST-HCR

HST, HST-R, HST-HCR			M8	M10	M12	M16	M20 ¹⁾	M24 ¹⁾
Nominal diameter of drill bit	d_0	[mm]	8	10	12	16	20	24
Cutting diameter of drill bit	$d_{cut} \leq$	[mm]	8,45	10,45	12,50	16,50	20,55	24,55
Drill hole depth	$h_1 \geq$	[mm]	65	80	95	115	140	170
Effective embedment depth	h_{ef}	[mm]	47	60	70	82	101	125
Nominal embedment depth	h_{nom}	[mm]	55	69	80	95	117	143
Maximum diameter of clearance hole in the fixture ²⁾	d_f	[mm]	9	12	14	18	22	26
Installation torque moment	T_{inst}	[Nm]	20	45	60	110	240	300
Maximum thickness of fixture	$t_{fix,max} \leq$	[mm]	195	200	200	235	305	330
Width across flats	SW	[mm]	13	17	19	24	30	36

¹⁾ Only HST and HST-R

²⁾ For the design of bigger clearance holes in the fixture see EN 1992-4:2018.

Hilti metal expansion anchor HST, HST-R, HST-HCR, HST3, HST3-R

Intended use
Installation parameters

Annex B4

Table B9: Installation parameters for HST3 and HST3-R

HST3, HST3-R			M8	M10	M12	M16	M20	M24
Nominal diameter of drill bit	d_0	[mm]	8	10	12	16	20	24
Cutting diameter of drill bit for hammer drilling	$d_{cut} \leq$	[mm]	8,45	10,45	12,50	16,50	20,55	24,55
Drill hole depth ^{1) 3)}	$h_{1,1} \geq$	[mm]	-	$h_{ef} + 13$	$h_{ef} + 18$	$h_{ef} + 21$	-	-
Effective embedment depth	$h_{ef,1}$	[mm]	-	40-59	50-69	65-84	-	-
Nominal embedment depth	$h_{nom,1}$	[mm]	-	$h_{ef} + 8$	$h_{ef} + 10$	$h_{ef} + 13$	-	-
Drill hole depth ^{1) 3)}	$h_{1,2} \geq$	[mm]	$h_{ef} + 12$	$h_{ef} + 13$	$h_{ef} + 18$	$h_{ef} + 21$	$h_{ef} + 23$	151
Effective embedment depth	$h_{ef,2}$	[mm]	47-90	60-100	70-125	85-160	101-180	125
Nominal embedment depth	$h_{nom,2}$	[mm]	$h_{ef} + 7$	$h_{ef} + 8$	$h_{ef} + 10$	$h_{ef} + 13$	$h_{ef} + 15$	143
Maximum diameter of clearance hole in the fixture ²⁾	d_f	[mm]	9	12	14	18	22	26
Installation torque moment	T_{inst}	[Nm]	20	45	60	110	180	300
Maximum thickness of fixture	$t_{fix,max}$	[mm]	195	220	270	370	310	330
Width across flats	SW	[mm]	13	17	19	24	30	36

¹⁾ In case of diamond drilling + 5 mm for M8 to M10 and + 2 mm for M12 to M24

²⁾ For the design of bigger clearance holes in the fixture see EN 1992-4:2018.

³⁾ In case of hammer drilling with non-cleaned boreholes + 12 mm for M8 to M20

Hilti metal expansion anchor HST, HST-R, HST-HCR, HST3, HST3-R

Intended use
Installation parameters

Annex B5

HST, HST-R and HST-HCR

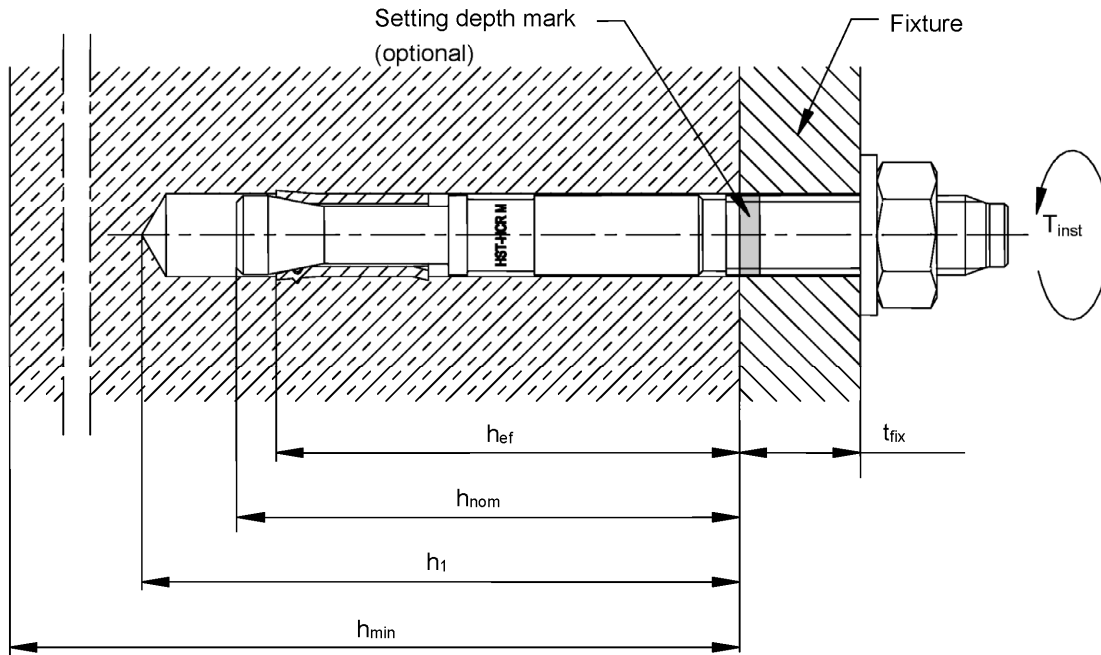

HST3 and HST3-R (standard embedment depth)

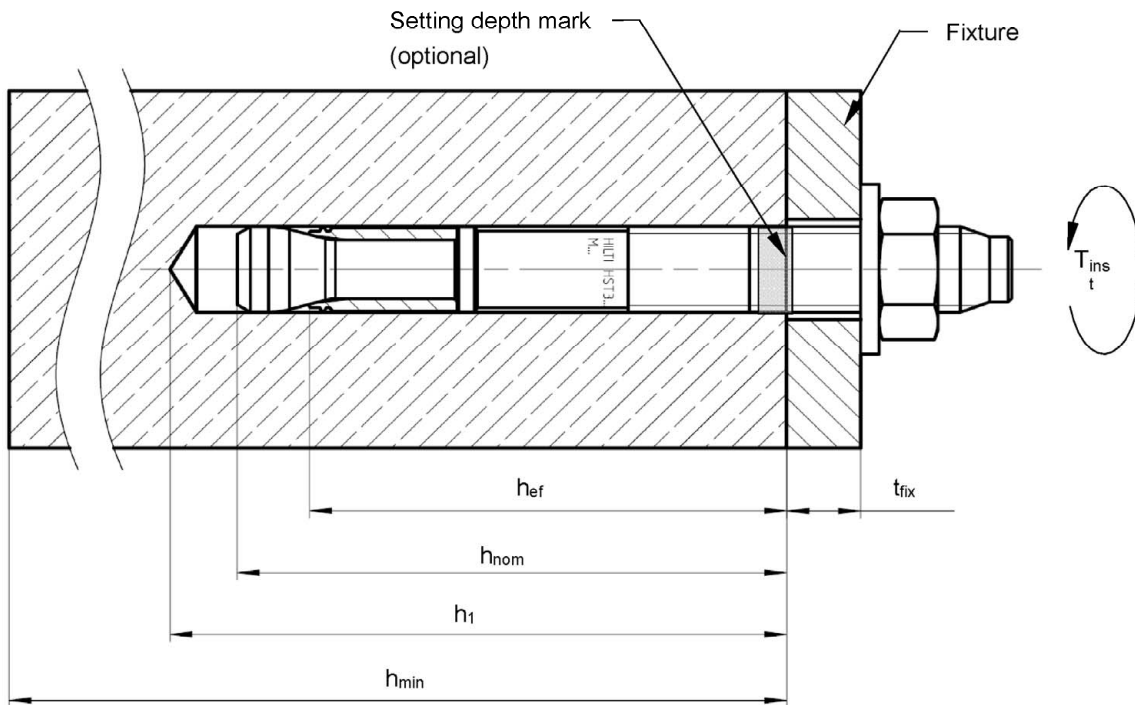

Hilti metal expansion anchor HST, HST-R, HST-HCR, HST3, HST3-R

Intended Use
Installation parameters

Annex B6

HST, HST-R, HST3 and HST3-R with Filling Set to fill the annular gap between anchor and fixture

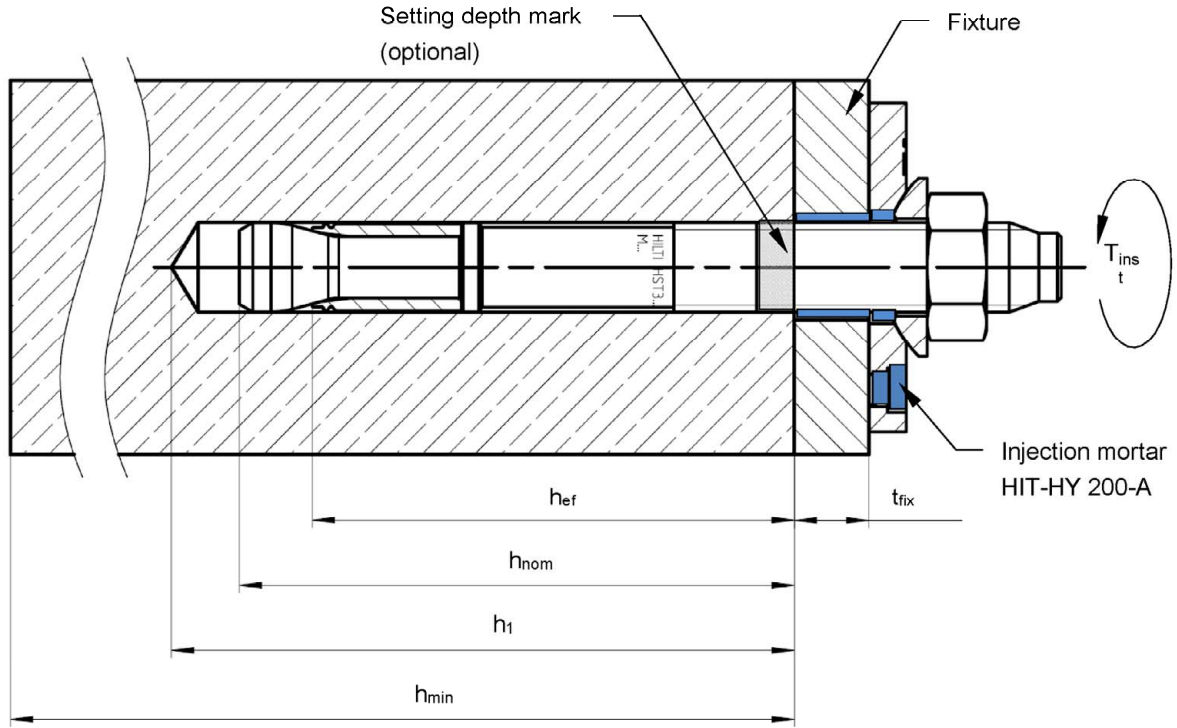

Hilti metal expansion anchor HST, HST-R, HST-HCR, HST3, HST3-R

Intended Use
Installation parameters

Annex B7

Table B10: Minimum spacing and edge distance for HST, HST-R and HST-HCR

		M8	M10	M12	M16	M20 ¹⁾	M24 ¹⁾
Minimum thickness of concrete member	h_{min} [mm]	100	120	140	160	200	250
Effective embedment depth	h_{ef} [mm]	47	60	70	82	101	125
Cracked concrete							
HST							
Minimum spacing ²⁾	s_{min} [mm]	40	55	60	70	100	125
	for $c \geq$ [mm]	50	70	75	100	160	180
Minimum edge distance ²⁾	c_{min} [mm]	45	55	55	70	100	125
	for $s \geq$ [mm]	50	90	120	150	225	240
HST-R							
Minimum spacing ²⁾	s_{min} [mm]	40	55	60	70	100	125
	for $c \geq$ [mm]	50	65	75	100	130	130
Minimum edge distance ²⁾	c_{min} [mm]	45	50	55	60	100	125
	for $s \geq$ [mm]	50	90	110	160	160	140
HST-HCR							
Minimum spacing ²⁾	s_{min} [mm]	40	55	60	70	3)	3)
	for $c \geq$ [mm]	50	70	75	100	3)	3)
Minimum edge distance ²⁾	c_{min} [mm]	45	50	55	60	3)	3)
	for $s \geq$ [mm]	50	90	110	160	3)	3)

¹⁾ Only HST and HST-R

²⁾ Linear interpolation for s_{min} and c_{min} allowed

³⁾ No performance assessed

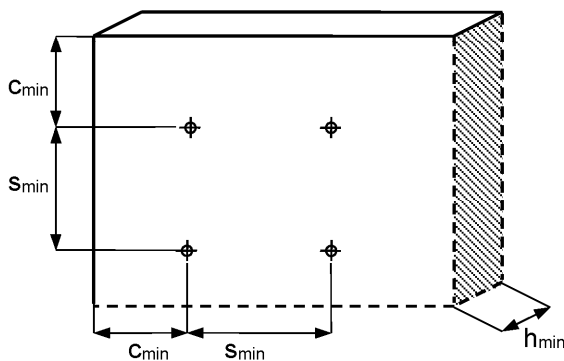

Hilti metal expansion anchor HST, HST-R, HST-HCR, HST3, HST3-R

Intended Use
Minimum spacing and minimum edge distance

Annex B8

Table B10 continued

		M8	M10	M12	M16	M20 ¹⁾	M24 ¹⁾
Minimum thickness of concrete member	h_{min} [mm]	100	120	140	160	200	250
Effective embedment depth	h_{ef} [mm]	47	60	70	82	101	125
Uncracked concrete							
HST							
Minimum spacing ²⁾	s_{min} [mm]	60	55	60	70	100	125
	for $c \geq$ [mm]	50	80	85	110	225	255
Minimum edge distance ²⁾	c_{min} [mm]	50	55	55	85	140	170
	for $s \geq$ [mm]	60	115	145	150	270	295
HST-R							
Minimum spacing ²⁾	s_{min} [mm]	60	55	60	70	100	125
	for $c \geq$ [mm]	60	70	80	110	195	205
Minimum edge distance ²⁾	c_{min} [mm]	60	50	55	70	140	150
	for $s \geq$ [mm]	60	115	145	160	210	235
HST-HCR							
Minimum spacing ²⁾	s_{min} [mm]	60	55	60	70	3)	3)
	for $c \geq$ [mm]	50	70	80	110	3)	3)
Minimum edge distance ²⁾	c_{min} [mm]	60	55	55	70	3)	3)
	for $s \geq$ [mm]	60	115	145	160	3)	3)

¹⁾ Only HST and HST-R

²⁾ Linear interpolation for s_{min} and c_{min} allowed

³⁾ No performance assessed

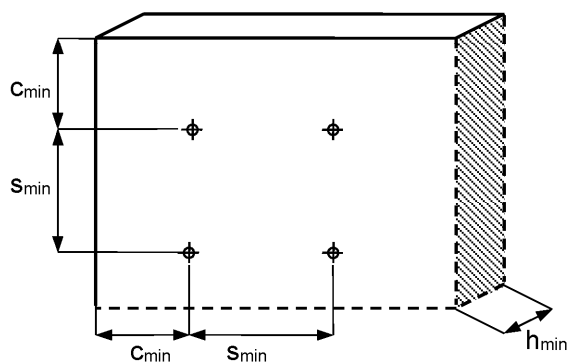

Hilti metal expansion anchor HST, HST-R, HST-HCR, HST3, HST3-R

Intended Use
Minimum spacing and minimum edge distance

Annex B9

Table B11: Minimum spacing and edge distance for HST3 and HST3-R

		M8	M10	M12	M16	M20	M24
Minimum thickness of concrete member	h_{min} [mm]	According Table B12					250
Effective embedment depth	$h_{ef,2}$ [mm]	According Table B12					125
Cracked concrete							
HST3							
Minimum spacing ¹⁾	s_{min} [mm]	According Table B12					125
	for $c \geq$ [mm]	According Table B12					180
Minimum edge distance ¹⁾	c_{min} [mm]	According Table B12					125
	for $s \geq$ [mm]	According Table B12					240
HST3-R							
Minimum spacing ¹⁾	s_{min} [mm]	According Table B12					125
	for $c \geq$ [mm]	According Table B12					130
Minimum edge distance ¹⁾	c_{min} [mm]	According Table B12					125
	for $s \geq$ [mm]	According Table B12					140

¹⁾ Linear interpolation for s_{min} and c_{min} allowed

²⁾ No performance assessed

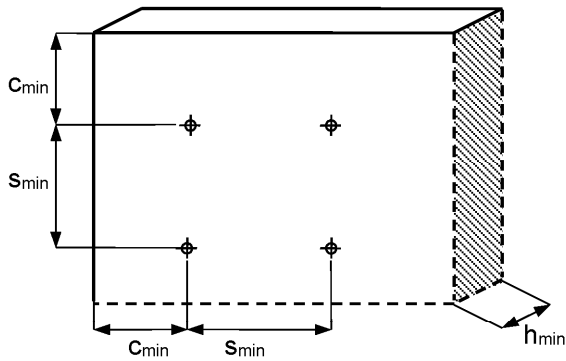

Hilti metal expansion anchor HST, HST-R, HST-HCR, HST3, HST3-R

Intended Use
Minimum spacing and minimum edge distance

Annex B10

Table B11 continued

		M8	M10	M12	M16	M20	M24
Minimum thickness of concrete member	h_{min} [mm]	According Table B12					250
Effective embedment depth	$h_{ef,2}$ [mm]	According Table B12					125
Uncracked concrete							
HST3							
Minimum spacing ¹⁾	s_{min} [mm]	According Table B12					125
	for $c \geq$ [mm]						255
Minimum edge distance ¹⁾	c_{min} [mm]						170
	for $s \geq$ [mm]						295
HST3-R							
Minimum spacing ¹⁾	s_{min} [mm]	According Table B12					125
	for $c \geq$ [mm]						205
Minimum edge distance ¹⁾	c_{min} [mm]						150
	for $s \geq$ [mm]						235

¹⁾ Linear interpolation for s_{min} and c_{min} allowed

²⁾ No performance assessed

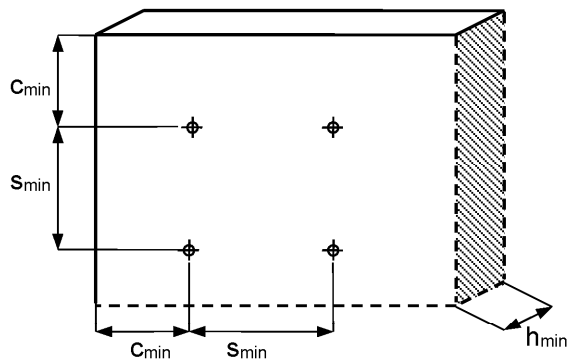

Hilti metal expansion anchor HST, HST-R, HST-HCR, HST3, HST3-R

Intended Use
Minimum spacing and minimum edge distance

Annex B11

Table B12: Minimum spacing and edge distance for HST3 and HST3-R

			M8	M10	M12	M16	M20	M24	
Minimum thickness of concrete member	h_{min}	[mm]	$80 + h_{ef} - h_{ef,min}$	$80 + h_{ef} - h_{ef,min}$	$100 + h_{ef} - h_{ef,min}$	$120 + h_{ef} - h_{ef,min}$	$160 + h_{ef} - h_{ef,min}$		According to Table B11
Minimum effective embedment depth	$h_{ef,min}$	[mm]	47	40	50	65	101		
Cracked concrete									
HST3 and HST3-R									
Minimum spacing	s_{min}	[mm]	35	40	50	65	90		According to Table B11
	for $c \geq$	[mm]	According to Table B13						
Minimum edge distance	c_{min}	[mm]	40	45	55	65	80		
	for $s \geq$	[mm]	According to Table B13						
Minimum required splitting area	$A_{sp,req.}$	[mm ²]	$15,0 \cdot 10^3$	$23,7 \cdot 10^3$	$33,5 \cdot 10^3$	$44,7 \cdot 10^3$	$61,0 \cdot 10^3$		1)
Uncracked concrete									
HST3 and HST3-R									
Minimum spacing	s_{min}	[mm]	35	40	50	65	90		According to Table B11
	for $c \geq$	[mm]	According to Table B13						
Minimum edge distance	c_{min}	[mm]	40	45	55	65	80		
	for $s \geq$	[mm]	According to Table B13						
Minimum required splitting area	$A_{sp,req.}$	[mm ²]	$19,6 \cdot 10^3$	$31,0 \cdot 10^3$	$43,9 \cdot 10^3$	$58,4 \cdot 10^3$	$79,8 \cdot 10^3$		1)

1) No performance assessed

For the calculation of the minimum edge distance and spacing in combination with variable embedment depths and slab thicknesses the following equation has to be fulfilled:

$$A_{sp,ef} \geq A_{sp,req.}$$

With:

$A_{sp,ef}$: Effective splitting area according to Table B13

$A_{sp,req.}$: Minimum required splitting area according to Table B12

Hilti metal expansion anchor HST, HST-R, HST-HCR, HST3, HST3-R

Intended Use
Minimum spacing and minimum edge distance

Annex B12

Table B13: Effective splitting area HST3 and HST3-R

Effective splitting area $A_{sp,ef}$ for concrete slab thickness $h > h_{ef} + 1,5 \cdot c$ and $h \geq h_{min}$			
Anchors and anchor groups with ¹⁾	$s > 3 \cdot c$ $h_{ef} < 1,5 \cdot c$	$A_{sp,ef} = (6 \cdot c) \cdot (h_{ef} + 1,5 \cdot c)$ [mm ²]	For $c \geq c_{min}$
Anchor groups with ¹⁾	$s \leq 3 \cdot c$ $h_{ef} < 1,5 \cdot c$	$A_{sp,ef} = (3 \cdot c + s) \cdot (h_{ef} + 1,5 \cdot c)$ [mm ²]	For $c \geq c_{min}$ $s \geq s_{min}$
Anchors and anchor groups with ¹⁾	$s > 3 \cdot c$ $h_{ef} \geq 1,5 \cdot c$	$A_{sp,ef} = (6 \cdot c) \cdot (3 \cdot c)$ [mm ²]	For $c \geq c_{min}$
Anchor groups with ¹⁾	$s \leq 3 \cdot c$ $h_{ef} \geq 1,5 \cdot c$	$A_{sp,ef} = (3 \cdot c + s) \cdot (3 \cdot c)$ [mm ²]	For $c \geq c_{min}$ $s \geq s_{min}$
Effective splitting area $A_{sp,ef}$ for concrete slab thickness $h \leq h_{ef} + 1,5 \cdot c$ and $h \geq h_{min}$			
Anchors and anchor groups with ¹⁾	$s > 3 \cdot c$ $h_{ef} < 1,5 \cdot c$	$A_{sp,ef} = (6 \cdot c) \cdot h$ [mm ²]	For $c \geq c_{min}$
Anchor groups with ¹⁾	$s \leq 3 \cdot c$ $h_{ef} < 1,5 \cdot c$	$A_{sp,ef} = (3 \cdot c + s) \cdot h$ [mm ²]	For $c \geq c_{min}$ $s \geq s_{min}$
Anchors and anchor groups with ¹⁾	$s > 3 \cdot c$ $h_{ef} \geq 1,5 \cdot c$	$A_{sp,ef} = (6 \cdot c) \cdot (h - h_{ef} + 1,5 \cdot c)$ [mm ²]	For $c \geq c_{min}$
Anchor groups with ¹⁾	$s \leq 3 \cdot c$ $h_{ef} \geq 1,5 \cdot c$	$A_{sp,ef} = (3 \cdot c + s) \cdot (h - h_{ef} + 1,5 \cdot c)$ [mm ²]	For $c \geq c_{min}$ $s \geq s_{min}$

¹⁾ Edge distance and spacing must be rounded up to increments of 5 mm

Hilti metal expansion anchor HST, HST-R, HST-HCR, HST3, HST3-R

Intended Use
Minimum spacing and minimum edge distance

Annex B13

Installation instruction HST, HST-R and HST-HCR

Hole drilling and cleaning

- a) Hammer drilling (HD):
M8 to M24

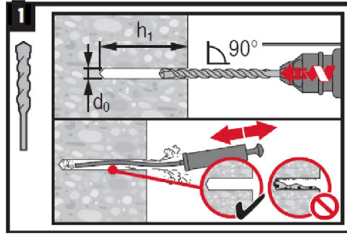

Anchor setting

- a) Hammer setting:
M8 to M24

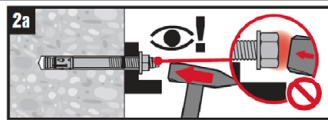

- b) Machine setting (setting tool):
M8 to M24

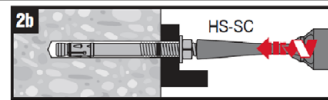

Check setting

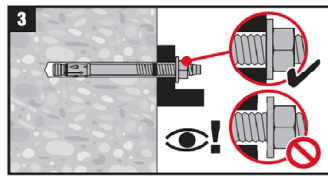

Anchor torquing

- a) Torque wrench:
M8 to M24

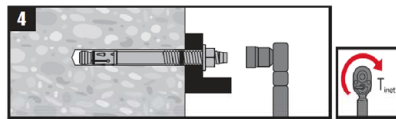

Hilti metal expansion anchor HST, HST-R, HST-HCR, HST3, HST3-R

Intended Use
Installation instructions

Annex B14

Installation instruction HST3 and HST3-R

Hole drilling and cleaning

a) Hammer drilling (HD):
M8 to M24

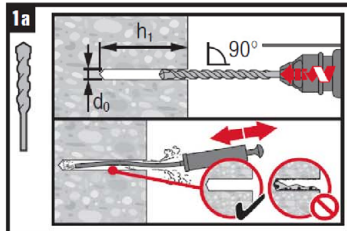

b) Diamond coring (DD):
M8 to M24

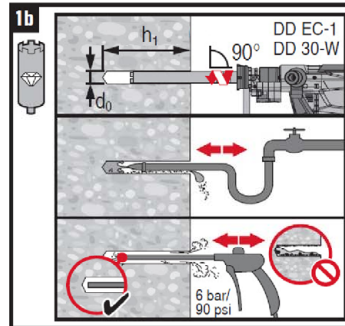

c) Hammer drilling with Hilti hollow drill bit (HDB):
M12 to M24

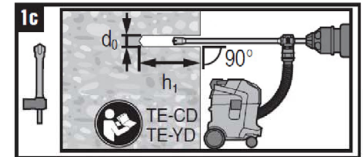

Hole drilling (without cleaning)

a) Hammer drilling
non-cleaned (HD nc):
M8 to M20

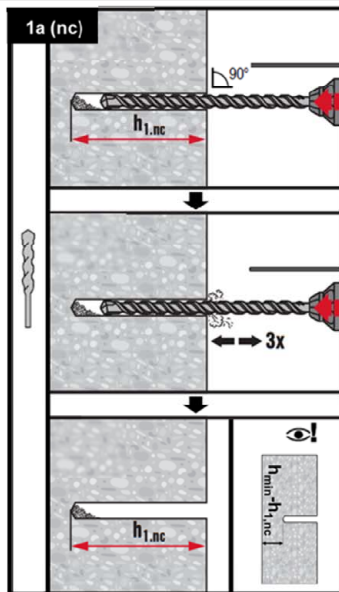

Anchor setting

a) Hammer setting:

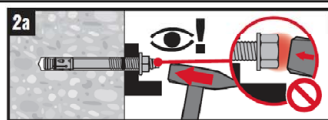

b) Machine setting (setting tool):

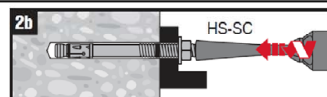

Hilti metal expansion anchor HST, HST-R, HST-HCR, HST3, HST3-R

Intended Use
Installation instructions

Annex B15

Installation instruction HST3 and HST3-R

Check setting

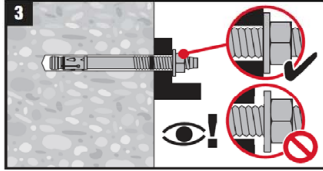

Anchor torquing

a) Torque wrench:
M8 to M24

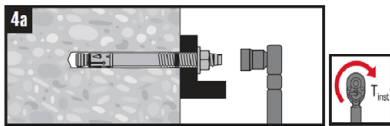

b) Machine torquing:
M8 to M16

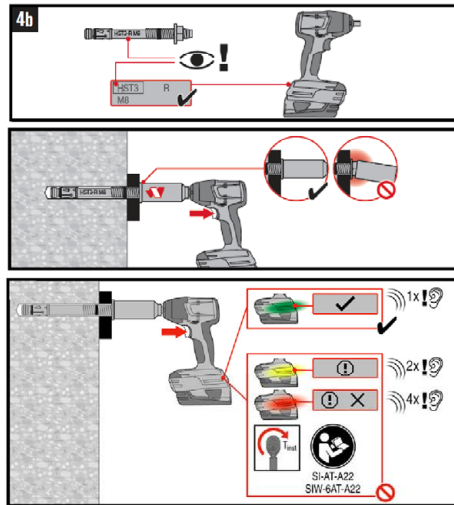

Hilti metal expansion anchor HST, HST-R, HST-HCR, HST3, HST3-R

Intended Use
Installation instructions

Annex B16

Installation instruction HST, HST-R, HST3 and HST3-R with Filling Set

Installation of sealing washer

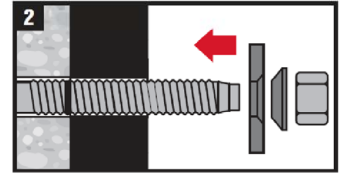
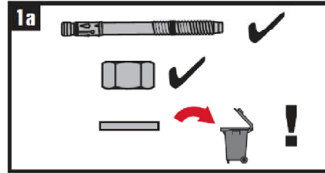
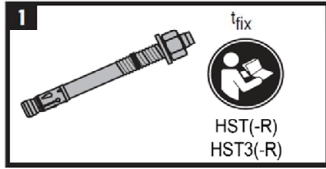

Anchor torquing

a) Torque wrench:
M8 to M20

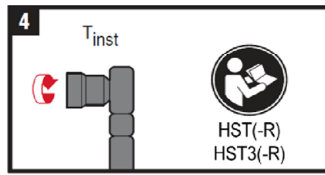
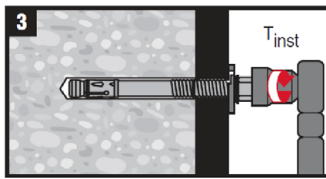

Installation of counter nut (optional)

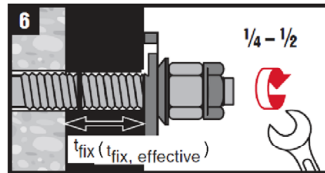
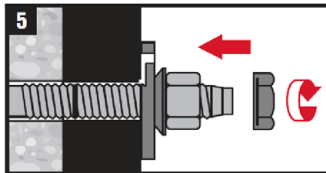

Injection of mortar

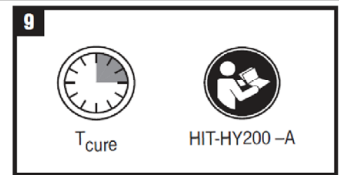
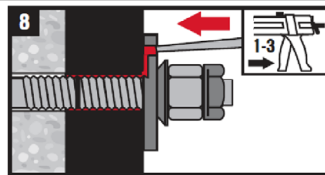

Hilti metal expansion anchor HST, HST-R, HST-HCR, HST3, HST3-R

Intended Use
Installation instructions

Annex B17

Table C1: Characteristic tension resistance for Hilti metal expansion anchor HST, HST-R and HST-HCR in cracked and uncracked concrete

			M8	M10	M12	M16	M20 ¹⁾	M24 ¹⁾	
Steel failure									
HST									
Characteristic resistance	$N_{Rk,s}$	[kN]	19,0	32,0	45,0	76,0	117,0	127,0	
Partial safety factor	γ_{Ms} ²⁾	[-]	1,50					1,41	
HST-R									
Characteristic resistance	$N_{Rk,s}$	[kN]	17,0	28,0	40,0	69,0	109,0	156,0	
Partial safety factor	γ_{Ms} ²⁾	[-]	1,50			1,56	1,73		
HST-HCR									
Characteristic resistance	$N_{Rk,s}$	[kN]	19,4	32,3	45,7	84,5	³⁾	³⁾	
Partial safety factor	γ_{Ms} ²⁾	[-]	1,50				³⁾	³⁾	
Pullout failure									
HST									
Characteristic resistance in cracked concrete C20/25	$N_{Rk,p}$	[kN]	5,0	9,0	12,0	20,0	30,0	40,0	
Characteristic resistance in uncracked concrete C20/25	$N_{Rk,p}$	[kN]	9,0	16,0	20,0	35,0	50,0	60,0	
Installation safety factor	γ_{inst}	[-]	1,20	1,00					
HST-R									
Characteristic resistance in cracked concrete C20/25	$N_{Rk,p}$	[kN]	5,0	9,0	12,0	25,0	30,0	40,0	
Characteristic resistance in uncracked concrete C20/25	$N_{Rk,p}$	[kN]	9,0	16,0	20,0	35,0	50,0	60,0	
Installation safety factor	γ_{inst}	[-]	1,00						
HST-HCR									
Characteristic resistance in cracked concrete C20/25	$N_{Rk,p}$	[kN]	5,0	9,0	12,0	25,0	³⁾	³⁾	
Characteristic resistance in uncracked concrete C20/25	$N_{Rk,p}$	[kN]	9,0	16,0	20,0	35,0	³⁾	³⁾	
Installation safety factor	γ_{inst}	[-]	1,00				³⁾	³⁾	

¹⁾ Only HST and HST-R

²⁾ In absence of other national regulations

³⁾ No performance assessed

Hilti metal expansion anchor HST, HST-R, HST-HCR, HST3, HST3-R

Performances

Characteristic values of resistance under tension loading in cracked and uncracked concrete

Annex C1

Table C1 continued

			M8	M10	M12	M16	M20 ¹⁾	M24 ¹⁾
Pullout failure								
HST, HST-R and HST-HCR								
Increasing factor for $N_{Rk,p}$ for cracked and uncracked concrete	ψ_c	C20/25	1,00					
	ψ_c	C30/37	1,22					
	ψ_c	C40/50	1,41					
	ψ_c	C50/60	1,55					
Concrete cone and splitting failure								
HST, HST-R and HST-HCR								
Effective embedment depth	h_{ef}	[mm]	47	60	70	82	101	125
Factor for cracked concrete	$k_{cr,N}$	[-]	7,7					
Factor for uncracked concrete	$k_{ucr,N}$	[-]	11,0					
Characteristic resistance in uncracked concrete C20/25	$N^0_{Rk,sp}$	[kN]	9,0	16,0	20,0	35,0	50,0	60,0
Spacing	$s_{cr,N}$ $s_{cr,sp}$	[mm]	3 h_{ef}					
Edge distance	$c_{cr,N}$ $c_{cr,sp}$	[mm]	1,5 h_{ef}					

¹⁾ Only HST and HST-R

²⁾ In absence of other national regulations

³⁾ No performance assessed

Hilti metal expansion anchor HST, HST-R, HST-HCR, HST3, HST3-R

Performances

Characteristic values of resistance under tension loading in cracked and uncracked concrete

Annex C2

Table C2: Characteristic tension resistance for Hilti metal expansion anchor HST3 and HST3-R in cracked and uncracked concrete

			M8	M10	M12	M16	M20	M24
Steel failure								
HST3								
Characteristic resistance	$N_{Rk,s}$	[kN]	19,7	32,5	45,1	76,0	124,2	127,0
Partial safety factor	$\gamma_{Ms}^{1)}$	[-]	1,40					1,41
HST3-R								
Characteristic resistance	$N_{Rk,s}$	[kN]	17,7	28,7	42,5	69,4	115,8	156,0
Partial safety factor	$\gamma_{Ms}^{1)}$	[-]	1,40					1,56
Pullout failure								
HST3								
Effective embedment depth	$h_{ef,2}$	[mm]	47-90	60-100	70-125	85-160	101-180	125
Characteristic resistance in cracked concrete C20/25	$N_{Rk,p}$	[kN]	8,0	15,0	20,0	27,0	35,0	40,0
Characteristic resistance in uncracked concrete C20/25	$N_{Rk,p}$	[kN]	12,0	22,0	25,0	38,6	49,9	60,0
Installation safety factor	γ_{inst}	[-]	1,00					
HST3-R								
Effective embedment depth	$h_{ef,2}$	[mm]	47-90	60-100	70-125	85-160	101-180	125
Characteristic resistance in cracked concrete C20/25	$N_{Rk,p}$	[kN]	8,5	15,0	20,0	27,0	35,0	40,0
Characteristic resistance in uncracked concrete C20/25	$N_{Rk,p}$	[kN]	12,0	22,0	25,0	38,6	49,9	60,0
Installation safety factor	γ_{inst}	[-]	1,00					
HST3 and HST3-R								
Effective embedment depth	$h_{ef,1}$	[mm]	2)	40-59	50-69	65-84	2)	2)
Characteristic resistance in cracked concrete C20/25	$N_{Rk,p}$	[kN]	2)	MIN (15,0; $N_{Rk,c}$)	$N_{Rk,c}$	$N_{Rk,c}$	2)	2)
Characteristic resistance in uncracked concrete C20/25	$N_{Rk,p}$	[kN]	2)	MIN (22,0; $N_{Rk,c}$)	MIN (25,0; $N_{Rk,c}$)	$N_{Rk,c}$	2)	2)
Installation safety factor	γ_{inst}	[-]	1,00					

¹⁾ In absence of other national regulations

²⁾ No performance assessed

Hilti metal expansion anchor HST, HST-R, HST-HCR, HST3, HST3-R

Performances

Characteristic values of resistance under tension loading in cracked and uncracked concrete

Annex C3

Table C2 continued

			M8	M10	M12	M16	M20	M24
Pullout Failure								
HST3 and HST3-R								
Increasing factor for $N_{Rk,p}$ for cracked and uncracked concrete	ψ_c	C20/25	1,00					
	ψ_c	C30/37	1,22					
	ψ_c	C40/50	1,41					
	ψ_c	C50/60	1,55					
Concrete cone and splitting failure								
HST3 und HST3-R								
Effective embedment depth	$h_{ef,2}$	[mm]	47-90	60-100	70-125	85-160	101-180	125
Installation safety factor	γ_{inst}	[-]	1,00					
Factor for cracked concrete	$k_{cr,N}$	[-]	7,7					
Factor for uncracked concrete	$k_{ucr,N}$	[-]	11,0					
Characteristic resistance in uncracked concrete C20/25	$N^0_{Rk,sp}$	[kN]	12,0	22,0	25,0	38,6	49,9	60,0
Spacing	$s_{cr,N}$	[mm]	3 h_{ef}					
Edge distance	$c_{cr,N}$	[mm]	1,5 h_{ef}					
Spacing	$s_{cr,sp}$	[mm]	3 h_{ef}				3,8 h_{ef}	3 h_{ef}
Edge distance	$c_{cr,sp}$	[mm]	1,5 h_{ef}				1,9 h_{ef}	1,5 h_{ef}
HST3 und HST3-R								
Effective embedment depth	$h_{ef,1}$	[mm]	2)	40-59	50-69	65-84	2)	2)
Installation safety factor	γ_{inst}	[-]	2)	1,00			2)	2)
Factor for cracked concrete	$k_{cr,N}$	[-]	2)	7,7			2)	2)
Factor for uncracked concrete	$k_{ucr,N}$	[-]	2)	11,0			2)	2)
Characteristic resistance in uncracked concrete C20/25	$N^0_{Rk,sp}$	[kN]	2)	MIN (22,0; $N_{Rk,c}$)	MIN (25,0; $N_{Rk,c}$)	$N_{Rk,c}$	2)	2)
Spacing	$s_{cr,N}$	[mm]	2)	3 h_{ef}			2)	2)
Edge distance	$c_{cr,N}$	[mm]	2)	1,5 h_{ef}			2)	2)
Spacing	$s_{cr,sp}$	[mm]	2)	4,2 h_{ef}	3,6 h_{ef}	3,2 h_{ef}	2)	2)
Edge distance	$c_{cr,sp}$	[mm]	2)	2,1 h_{ef}	1,8 h_{ef}	1,6 h_{ef}	2)	2)

1) In absence of other national regulations

2) No performance assessed

Hilti metal expansion anchor HST, HST-R, HST-HCR, HST3, HST3-R

Performances

Characteristic values of resistance under tension loading in cracked and uncracked concrete

Annex C4

Table C3: Characteristic shear resistance for Hilti metal expansion anchor HST, HST-R and HST-HCR in cracked and uncracked concrete

			M8	M10	M12	M16	M20 ¹⁾	M24 ¹⁾	
Steel failure, shear force without lever arm									
HST									
Characteristic resistance	$V_{RK,s}^0$	[kN]	14,0	23,5	35,0	55,0	84,0	94,0	
Partial safety factor	$\gamma_{Ms}^{2)}$	[-]	1,25					1,50	
Ductility factor	k_7	[-]	1,00						
HST-R									
Characteristic resistance	$V_{RK,s}^0$	[kN]	13,0	20,0	30,0	50,0	80,0	115,0	
Partial safety factor	$\gamma_{Ms}^{2)}$	[-]	1,25			1,30	1,44		
Ductility factor	k_7	[-]	1,00						
HST-HCR									
Characteristic resistance	$V_{RK,s}^0$	[kN]	13,0	20,0	30,0	55,0	³⁾	³⁾	
Partial safety factor	$\gamma_{Ms}^{2)}$	[-]	1,25				³⁾	³⁾	
Ductility factor	k_7	[-]	1,00				³⁾	³⁾	
Steel failure, shear force with lever arm									
HST									
Characteristic resistance	$M_{RK,s}^0$	[Nm]	30	60	105	240	454	595	
Partial safety factor	$\gamma_{Ms}^{2)}$	[-]	1,25					1,50	
HST-R									
Characteristic resistance	$M_{RK,s}^0$	[Nm]	27	53	92	216	422	730	
Partial safety factor	$\gamma_{Ms}^{2)}$	[-]	1,25			1,30	1,44		
HST-HCR									
Characteristic resistance	$M_{RK,s}^0$	[Nm]	30	60	105	266	³⁾	³⁾	
Partial safety factor	$\gamma_{Ms}^{2)}$	[-]	1,25				³⁾	³⁾	

¹⁾ Only HST and HST-R

²⁾ In absence of other national regulations

³⁾ No performance assessed

Hilti metal expansion anchor HST, HST-R, HST-HCR, HST3, HST3-R

Performances

Characteristic values of resistance under shear loading in cracked and uncracked concrete

Annex C5

Table C3 continued

			M8	M10	M12	M16	M20 ¹⁾	M24 ¹⁾
Concrete pryout failure								
HST, HST-R and HST-HCR								
Installation safety factor	γ_{inst}	[-]	1,00					
Pryout factor	k_8	[-]	2,0	2,0	2,2	2,5	2,5	2,5
Concrete edge failure								
HST, HST-R and HST-HCR								
Effective length of anchor in shear loading	l_f	[mm]	47	60	70	82	101	125
Diameter of anchor	d_{nom}	[mm]	8	10	12	16	20	24
Installation safety factor	γ_{inst}	[-]	1,00					

¹⁾ Only HST and HST-R

²⁾ In absence of other national regulations

³⁾ No performance assessed

Hilti metal expansion anchor HST, HST-R, HST-HCR, HST3, HST3-R

Performances

Characteristic values of resistance under shear loading in cracked and uncracked concrete

Annex C6

Table C4: Characteristic shear resistance for Hilti metal expansion anchor HST3 and HST3-R in cracked and uncracked concrete

			M8	M10	M12	M16	M20	M24
Steel failure, shear force without lever arm								
HST3								
Effective embedment depth	$h_{ef,2}$	[mm]	47-90	60-100	70-125	85-160	101-180	125
Characteristic resistance	$V^0_{RK,s}$	[kN]	13,8	23,6	35,4	55,3	83,9	94,0
Characteristic resistance using Filling Set	$V^0_{RK,s}$	[kN]	16,6	25,8	39,0	60,9	100,4	2)
Partial safety factor	$\gamma_{Ms}^{1)}$	[-]	1,25					1,50
Ductility factor	k_7	[-]	1,00					
HST3-R								
Effective embedment depth	$h_{ef,2}$	[mm]	47-90	60-100	70-125	85-160	101-180	125
Characteristic resistance	$V^0_{RK,s}$	[kN]	15,7	25,3	36,7	63,6	97,2	115,0
Characteristic resistance using Filling Set	$V^0_{RK,s}$	[kN]	19,5	28,4	44,3	70,2	102,7	2)
Partial safety factor	$\gamma_{Ms}^{1)}$	[-]	1,25					1,30
Ductility factor	k_7	[-]	1,00					
HST3								
Effective embedment depth	$h_{ef,1}$	[mm]	2)	40-59	50-69	65-84	2)	2)
Characteristic resistance	$V^0_{RK,s}$	[kN]	2)	21,9	34,0	54,5	2)	2)
Partial safety factor	$\gamma_{Ms}^{1)}$	[-]	2)	1,25			2)	2)
Ductility factor	k_7	[-]	2)	1,00			2)	2)
HST3-R								
Effective embedment depth	$h_{ef,1}$	[mm]	2)	40-59	50-69	65-84	2)	2)
Characteristic resistance	$V^0_{RK,s}$	[kN]	2)	25,6	31,1	48,6	2)	2)
Partial safety factor	$\gamma_{Ms}^{1)}$	[-]	2)	1,25			2)	2)
Ductility factor	k_7	[-]	2)	1,00			2)	2)

¹⁾ In absence of other national regulations

²⁾ No performance assessed

Hilti metal expansion anchor HST, HST-R, HST-HCR, HST3, HST3-R

Performances

Characteristic values of resistance under shear loading in cracked and uncracked concrete

Annex C7

Table C4 continued

		M8	M10	M12	M16	M20	M24	
Steel failure, shear force with lever arm								
HST3								
Characteristic resistance	$M_{Rk,s}^0$ [Nm]	30	60	105	240	457	595	
Partial safety factor	$\gamma_{Ms}^{1)}$ [-]	1,25					1,50	
HST3-R								
Characteristic resistance	$M_{Rk,s}^0$ [Nm]	27	53	93	216	425	730	
Partial safety factor	$\gamma_{Ms}^{1)}$ [-]	1,25					1,30	
Concrete pryout failure								
HST3 and HST3-R								
Effective embedment depth	$h_{ef,2}$ [mm]	47-90	60-100	70-125	85-160	101-180	125	
Installation safety factor	γ_{inst} [-]	1,00						
Pryout factor	k_8 [-]	2,62	2,67	2,78	3,41	3,20	2,50	
HST3 and HST3-R								
Effective embedment depth	$h_{ef,1}$ [mm]	²⁾	40-59	50-69	65-84	²⁾	²⁾	
Installation safety factor	γ_{inst} [-]	1,00						
Pryout factor	k_8 [-]	²⁾	2,67	2,78	3,41	²⁾	²⁾	
Concrete edge failure								
HST3 and HST3-R								
Effective length of anchor in shear loading	$l_{f,2}$ [mm]	47-90	60-100	70-125	85-160	101-180	125	
Effective length of anchor in shear loading with shallow embedment depth	$l_{f,1}$ [mm]	²⁾	40-59	50-69	65-84	²⁾	²⁾	
Diameter of anchor	d_{nom} [mm]	8	10	12	16	20	24	
Installation safety factor	γ_{inst} [-]	1,00						

¹⁾ In absence of other national regulations

²⁾ No performance assessed

Hilti metal expansion anchor HST, HST-R, HST-HCR, HST3, HST3-R

Performances

Characteristic values of resistance under shear loading in cracked and uncracked concrete

Annex C8

Table C5: Displacements under tension and shear loads for Hilti metal expansion anchor HST, HST-R and HST-HCR for static and quasi static loading

			M8	M10	M12	M16	M20 ¹⁾	M24 ¹⁾
Displacements under tension loading								
HST								
Tension load in cracked concrete	N	[kN]	2,0	4,3	5,7	9,5	14,3	19,0
Corresponding displacement	δ_{N0}	[mm]	1,3	0,2	0,1	0,5	1,9	2,2
	$\delta_{N\infty}$	[mm]	1,2	1,0	1,2	1,2	2,3	2,5
Tension load in uncracked concrete	N	[kN]	3,6	7,6	9,5	16,7	23,8	28,6
Corresponding displacement	δ_{N0}	[mm]	0,2	0,1	0,1	0,4	0,6	0,5
	$\delta_{N\infty}$	[mm]	1,1	1,1	1,1	1,1	1,4	1,4
HST-R and HST-HCR								
Tension load in cracked concrete	N	[kN]	2,4	4,3	5,7	11,9	14,3	19,0
Corresponding displacement	δ_{N0}	[mm]	0,6	0,2	0,8	1,0	1,1	0,8
	$\delta_{N\infty}$	[mm]	1,5	1,2	1,4	1,2	1,2	1,7
Tension load in uncracked concrete	N	[kN]	4,3	7,6	9,5	16,7	23,8	28,6
Corresponding displacement	δ_{N0}	[mm]	0,1	0,1	0,1	0,1	0,5	0,8
	$\delta_{N\infty}$	[mm]	1,5	1,2	1,4	1,2	1,2	1,7
Displacements under shear loading								
HST								
Shear load in cracked and uncracked concrete	V	[kN]	8,0	13,4	20,0	31,4	48,0	45,0
Corresponding displacement	δ_{V0}	[mm]	2,5	2,5	3,7	4,0	2,7	2,0
	$\delta_{V\infty}$	[mm]	3,8	3,7	5,5	6,0	4,1	3,0
HST-R and HST-HCR								
Shear load in cracked and uncracked concrete	V	[kN]	7,4	11,0	17,0	27,5	40,0	57,0
Corresponding displacement	δ_{V0}	[mm]	1,6	3,3	4,9	2,2	2,5	2,5
	$\delta_{V\infty}$	[mm]	2,4	4,9	7,4	3,3	3,7	3,7

¹⁾ Only HST and HST-R

Hilti metal expansion anchor HST, HST-R, HST-HCR, HST3, HST3-R

Performances
Displacements under tension and shear loading

Annex C9

Table C6: Displacements under tension and shear loads for Hilti metal expansion anchor HST3 and HST3-R for static and quasi static loading

			M8	M10	M12	M16	M20	M24
Displacements under tension loading								
HST3								
Effective embedment depth	$h_{ef,2}$	[mm]	47-90	60-100	70-125	85-160	101-180	125
Tension load in cracked concrete	N	[kN]	3,6	5,7	9,5	13,4	17,4	19,0
Corresponding displacement	δ_{N0}	[mm]	0,6	0,6	0,8	1,8	1,3	2,2
	$\delta_{N\infty}$	[mm]	1,1	1,3	1,6	1,7	1,8	2,5
Tension load in uncracked concrete	N	[kN]	5,7	9,5	11,9	18,9	24,4	28,6
Corresponding displacement	δ_{N0}	[mm]	0,2	0,3	0,2	0,8	0,5	0,5
	$\delta_{N\infty}$	[mm]	0,4	0,5	0,4	1,5	0,9	1,4
HST3-R								
Effective embedment depth	$h_{ef,2}$	[mm]	47-90	60-100	70-125	85-160	101-180	125
Tension load in cracked concrete	N	[kN]	3,6	5,7	9,5	13,4	17,4	19,0
Corresponding displacement	δ_{N0}	[mm]	0,6	0,6	0,8	1,8	1,3	0,8
	$\delta_{N\infty}$	[mm]	1,1	1,3	1,6	1,7	1,8	1,7
Tension load in uncracked concrete	N	[kN]	5,7	9,5	11,9	18,9	24,4	28,6
Corresponding displacement	δ_{N0}	[mm]	0,2	0,3	0,2	0,8	0,5	0,8
	$\delta_{N\infty}$	[mm]	0,4	0,5	0,4	1,5	0,9	1,7
HST3 and HST3-R								
Effective embedment depth	$h_{ef,1}$	[mm]	1)	40-59	50-69	65-84	1)	1)
Tension load in cracked concrete	N	[kN]	1)	4,3	6,1	9,0	1)	1)
Corresponding displacement	δ_{N0}	[mm]	1)	0,6	0,4	0,6	1)	1)
	$\delta_{N\infty}$	[mm]	1)	1,3	1,6	1,7	1)	1)
Tension load in uncracked concrete	N	[kN]	1)	6,1	8,5	12,6	1)	1)
Corresponding displacement	δ_{N0}	[mm]	1)	0,2	0,7	0,8	1)	1)
	$\delta_{N\infty}$	[mm]	1)	0,4	1,2	1,5	1)	1)

¹⁾ No performance assessed

Hilti metal expansion anchor HST, HST-R, HST-HCR, HST3, HST3-R

Performances
Displacements under tension and shear loading

Annex C10

Table C6 continued

		M8	M10	M12	M16	M20	M24
Displacements under shear loading							
HST3							
Effective embedment depth	$h_{ef,2}$ [mm]	47-90	60-100	70-125	85-160	101-180	125
Shear load in cracked and uncracked concrete	V [kN]	7,9	13,5	20,2	31,6	47,9	45,0
Corresponding displacement	δ_{V0} [mm]	2,8	2,5	3,8	4,3	2,7	2,0
	$\delta_{V\infty}$ [mm]	4,2	3,7	5,6	6,4	4,1	3,0
Shear load in cracked and uncracked concrete using Filling Set	V [kN]	9,5	14,7	22,3	34,8	57,4	¹⁾
Corresponding displacement	δ_{V0} [mm]	2,9	2,3	2,0	2,3	5,9	¹⁾
	$\delta_{V\infty}$ [mm]	4,4	3,4	3,0	3,5	8,8	¹⁾
HST3-R							
Effective embedment depth	$h_{ef,2}$ [mm]	47-90	60-100	70-125	85-160	101-180	125
Shear load in cracked and uncracked concrete	V [kN]	8,9	14,5	21,0	36,3	55,6	57,0
Corresponding displacement	δ_{V0} [mm]	7,1	2,3	3,3	5,7	3,2	2,5
	$\delta_{V\infty}$ [mm]	10,7	3,4	4,9	8,5	4,8	3,7
Shear load in cracked and uncracked concrete using Filling Set	V [kN]	11,1	16,2	25,3	40,1	58,7	¹⁾
Corresponding displacement	δ_{V0} [mm]	1,9	2,0	2,3	3,4	4,9	¹⁾
	$\delta_{V\infty}$ [mm]	2,9	3,0	3,4	5,0	7,3	¹⁾

¹⁾ No performance assessed

Hilti metal expansion anchor HST, HST-R, HST-HCR, HST3, HST3-R

Performances
Displacements under tension and shear loading

Annex C11

Table C6 continued

		M8	M10	M12	M16	M20	M24
Displacements under shear loading							
HST3							
Effective embedment depth	$h_{ef,1}$ [mm]	1)	40-59	50-69	65-84	1)	1)
Shear load in cracked and uncracked concrete	V [kN]	1)	12,5	19,4	31,1	1)	1)
Corresponding displacement	δ_{V0} [mm]	1)	4,2	3,1	4,4	1)	1)
	$\delta_{V\infty}$ [mm]	1)	6,3	4,7	6,6	1)	1)
HST3-R							
Effective embedment depth	$h_{ef,1}$ [mm]	1)	40-59	50-69	65-84	1)	1)
Shear load in cracked and uncracked concrete	V [kN]	1)	14,6	17,8	27,8	1)	1)
Corresponding displacement	δ_{V0} [mm]	1)	3,7	3,9	3,5	1)	1)
	$\delta_{V\infty}$ [mm]	1)	5,6	5,8	5,3	1)	1)

1) No performance assessed

Hilti metal expansion anchor HST, HST-R, HST-HCR, HST3, HST3-R

Performances
Displacements under tension and shear loading

Annex C12

Table C7: Characteristic tension resistance for seismic loading for Hilti metal expansion anchor HST and HST-R, performance category C1

			M8	M10	M12	M16	M20	M24
Steel failure								
HST								
Characteristic resistance	$N_{Rk,s,C1}$ [kN]		³⁾	32,0	45,0	76,0	³⁾	³⁾
Partial safety factor	$\gamma_{Ms,C1}$ ¹⁾	[-]	³⁾	1,50			³⁾	³⁾
HST-R								
Characteristic resistance	$N_{Rk,s,C1}$ [kN]		³⁾	28,0	40,0	69,0	³⁾	³⁾
Partial safety factor	$\gamma_{Ms,C1}$ ¹⁾	[-]	³⁾	1,50		1,56	³⁾	³⁾
Pullout failure								
HST and HST-R								
Characteristic resistance	$N_{Rk,p,C1}$ [kN]		³⁾	8,0	10,7	18,0	³⁾	³⁾
Installation safety factor	γ_{inst}	[-]	³⁾	1,00			³⁾	³⁾
Concrete cone failure ²⁾								
HST and HST-R								
Installation safety factor	γ_{inst}	[-]	³⁾	1,00			³⁾	³⁾
Splitting failure ²⁾								
HST and HST-R								
Installation safety factor	γ_{inst}	[-]	³⁾	1,00			³⁾	³⁾

¹⁾ In absence of other national regulations

²⁾ For concrete cone failure and splitting failure see EN 1992-4:2018

³⁾ No performance assessed

Hilti metal expansion anchor HST, HST-R, HST-HCR, HST3, HST3-R

Performances

Characteristic tension resistance for performance category C1

Annex C13

Table C8: Characteristic tension resistance for seismic loading for Hilti metal expansion anchor HST3 and HST3-R, performance category C1

		M8	M10	M12	M16	M20	M24
Steel failure							
HST3							
Effective embedment depth	$h_{ef,2}$ [mm]	47-90	60-100	70-125	85-160	101-180	3)
Characteristic resistance	$N_{Rk,s,C1}$ [kN]	19,7	32,5	45,1	76,0	124,2	3)
Partial safety factor	$\gamma_{Ms,C1}^{1)}$ [-]	1,40					3)
HST3-R							
Effective embedment depth	$h_{ef,2}$ [mm]	47-90	60-100	70-125	85-160	101-180	3)
Characteristic resistance	$N_{Rk,s,C1}$ [kN]	17,7	28,7	42,5	69,4	115,8	3)
Partial safety factor	$\gamma_{Ms,C1}^{1)}$ [-]	1,40					3)
Pullout failure							
HST3							
Effective embedment depth	$h_{ef,2}$ [mm]	47-90	60-100	70-125	85-160	101-180	3)
Characteristic resistance	$N_{Rk,p,C1}$ [kN]	8,0	15,0	20,0	27,0	35,0	3)
Installation safety factor	γ_{inst} [-]	1,00					3)
Effective embedment depth	$h_{ef,1}$ [mm]	3)	3)	50-69	3)	3)	3)
Characteristic resistance	$N_{Rk,p,C1}$ [kN]	3)	3)	12,2	3)	3)	3)
Installation safety factor	γ_{inst} [-]	1,00					3)
HST3-R							
Effective embedment depth	$h_{ef,2}$ [mm]	47-90	60-100	70-125	85-160	101-180	3)
Characteristic resistance	$N_{Rk,p,C1}$ [kN]	8,5	15,0	20,0	27,0	35,0	3)
Installation safety factor	γ_{inst} [-]	1,00					3)

1) In absence of other national regulations

2) For concrete cone failure and splitting failure see EN 1992-4:2018

3) No performance assessed

Hilti metal expansion anchor HST, HST-R, HST-HCR, HST3, HST3-R

Performances

Characteristic tension resistance for performance category C1

Annex C14

Table C8 continued

			M8	M10	M12	M16	M20	M24
Concrete cone failure ²⁾								
HST3 and HST3-R								
Effective embedment depth	$h_{ef,2}$	[mm]	47-90	60-100	70-125	85-160	101-180	³⁾
Installation safety factor	γ_{inst}	[-]	1,00					³⁾
Splitting failure ²⁾								
HST3 and HST3-R								
Effective embedment depth	$h_{ef,2}$	[mm]	47-90	60-100	70-125	85-160	101-180	³⁾
Installation safety factor	γ_{inst}	[-]	1,00					³⁾

¹⁾ In absence of other national regulations

²⁾ For concrete cone failure and splitting failure see EN 1992-4:2018

³⁾ No performance assessed

Hilti metal expansion anchor HST, HST-R, HST-HCR, HST3, HST3-R

Performances

Characteristic tension resistance for performance category C1

Annex C15

Table C9: Characteristic shear resistance for seismic loading for Hilti metal expansion anchor HST and HST-R, performance category C1

			M8	M10	M12	M16	M20	M24
Steel failure								
HST								
Partial safety factor	$\gamma_{Ms,C1}$ ¹⁾	[-]	3)	1,25			3)	3)
Characteristic resistance	$V_{Rk,s,C1}$	[kN]	3)	16,0	27,0	41,3	3)	3)
Reduction factor according to EN 1992-4:2018 with gap filling	α_{gap}	[-]	3)	1,0			3)	3)
Reduction factor according to EN 1992-4:2018 without gap filling	α_{gap}	[-]	3)	0,5			3)	3)
HST-R								
Partial safety factor	$\gamma_{Ms,C1}$ ¹⁾	[-]	3)	1,25		1,30	3)	3)
Characteristic resistance	$V_{Rk,s,C1}$	[kN]	3)	13,6	23,1	37,5	3)	3)
Reduction factor according to EN 1992-4:2018 with gap filling	α_{gap}	[-]	3)	1,0			3)	3)
Reduction factor according to EN 1992-4:2018 without gap filling	α_{gap}	[-]	3)	0,5			3)	3)
Concrete pryout failure²⁾								
HST and HST-R								
Installation safety factor	γ_{inst}	[-]	3)	1,00			3)	3)
Concrete edge failure²⁾								
HST and HST-R								
Installation safety factor	γ_{inst}	[-]	3)	1,00			3)	3)

¹⁾ In absence of other national regulations

²⁾ For concrete pryout failure and concrete edge failure see EN 1992-4:2018

³⁾ No performance assessed

Hilti metal expansion anchor HST, HST-R, HST-HCR, HST3, HST3-R

Performances
Characteristic shear resistance for performance category C1

Annex C16

Table C10: Characteristic shear resistance for seismic loading for Hilti metal expansion anchor HST3 and HST3-R, performance category C1

		M8	M10	M12	M16	M20	M24
Steel failure							
HST3							
Partial safety factor	$\gamma_{Ms,C1}^{1)}$ [-]	1,25					3)
Effective embedment depth	$h_{ef,2}$ [mm]	47-90	60-100	70-125	85-160	101-180	3)
Installation with Hilti filling set							
Characteristic resistance	$V_{Rk,s,C1}$ [kN]	16,6	25,8	39,0	60,9	100,4	3)
Reduction factor according to EN 1992-4:2018 with gap filling	α_{gap} [-]	1,0					3)
Installation without Hilti filling set							
Characteristic resistance	$V_{Rk,s,C1}$ [kN]	12,5	21,4	32,2	48,7	77,6	3)
Reduction factor according to EN 1992-4:2018 without gap filling	α_{gap} [-]	0,5					3)
Effective embedment depth	$h_{ef,1}$ [mm]	3)	3)	50-69	3)	3)	3)
Installation with / without Hilti filling set							
Characteristic resistance	$V_{Rk,s,C1}$ [kN]	3)	3)	32,3	3)	3)	3)
Reduction factor according to EN 1992-4:2018 with gap filling	α_{gap} [-]	1,0					3)
Reduction factor according to EN 1992-4:2018 without gap filling	α_{gap} [-]	0,5					3)
HST3-R							
Partial safety factor	$\gamma_{Ms,C1}^{1)}$ [-]	1,25					3)
Effective embedment depth	$h_{ef,2}$ [mm]	47-90	60-100	70-125	85-160	101-180	3)
Installation with Hilti filling set							
Characteristic resistance	$V_{Rk,s,C1}$ [kN]	19,5	28,4	44,3	70,2	102,7	3)
Reduction factor according to EN 1992-4:2018 with gap filling	α_{gap} [-]	1,0					3)
Installation without Hilti filling set							
Characteristic resistance	$V_{Rk,s,C1}$ [kN]	15,0	22,8	36,6	60,4	56,7	3)
Reduction factor according to EN 1992-4:2018 without gap filling	α_{gap} [-]	0,5					3)

Hilti metal expansion anchor HST, HST-R, HST-HCR, HST3, HST3-R

Performances

Characteristic shear resistance for performance category C1

Annex C17

Table C11 continued

Concrete pryout failure ²⁾								
HST3 and HST3-R								
Effective embedment depth	$h_{ef,2}$	[mm]	47-90	60-100	70-125	85-160	101-180	³⁾
Installation safety factor	γ_{inst}	[-]	1,00					³⁾
Concrete edge failure ²⁾								
HST3 and HST3-R								
Effective embedment depth	$h_{ef,2}$	[mm]	47-90	60-100	70-125	85-160	101-180	³⁾
Installation safety factor	γ_{inst}	[-]	1,00					³⁾

¹⁾ In absence of other national regulations

²⁾ For concrete pryout failure and concrete edge failure see EN 1992-4:2018

³⁾ No performance assessed

Hilti metal expansion anchor HST, HST-R, HST-HCR, HST3, HST3-R

Performances
Characteristic shear resistance for performance category C1

Annex C18

Table C12: Characteristic tension resistance for seismic loading for Hilti metal expansion anchor HST and HST-R, performance category C2

			M8	M10	M12	M16	M20	M24
Steel failure								
HST								
Characteristic resistance	$N_{Rk,s,C2}$ [kN]		³⁾	32,0	45,0	76,0	³⁾	³⁾
Partial safety factor	$\gamma_{Ms,C2}$ ¹⁾	[-]	³⁾	1,50			³⁾	³⁾
HST-R								
Characteristic resistance	$N_{Rk,s,C2}$ [kN]		³⁾	28,0	40,0	69,0	³⁾	³⁾
Partial safety factor	$\gamma_{Ms,C2}$ ¹⁾	[-]	³⁾	1,50		1,56	³⁾	³⁾
Pullout failure								
HST and HST-R								
Characteristic resistance	$N_{Rk,p,C2}$ [kN]		³⁾	3,3	10,0	12,8	³⁾	³⁾
Installation safety factor	γ_{inst}	[-]	³⁾	1,00			³⁾	³⁾
Concrete cone failure ²⁾								
HST and HST-R								
Installation safety factor	γ_{inst}	[-]	³⁾	1,00			³⁾	³⁾
Splitting failure ²⁾								
HST and HST-R								
Installation safety factor	γ_{inst}	[-]	³⁾	1,00			³⁾	³⁾

¹⁾ In absence of other national regulations

²⁾ For concrete cone failure and splitting failure see EN 1992-4:2018

³⁾ No performance assessed

Table C13: Displacements under tension loads for seismic loading for Hilti metal expansion anchor HST and HST-R, performance category C2

			M8	M10	M12	M16	M20	M24
HST and HST-R								
Displacement DLS	$\delta_{N,C2(DLS)}$ [mm]		¹⁾	1,4	6,7	4,0	¹⁾	¹⁾
Displacement ULS	$\delta_{N,C2(ULS)}$ [mm]		¹⁾	8,6	15,9	13,3	¹⁾	¹⁾

¹⁾ No performance assessed

Hilti metal expansion anchor HST, HST-R, HST-HCR, HST3, HST3-R

Performances

Characteristic tension resistance and displacements under tension loads for performance category C2

Annex C19

Table C14: Characteristic tension resistance for seismic loading for Hilti metal expansion anchor HST3 and HST3-R, performance category C2

			M8	M10	M12	M16	M20	M24
Steel failure								
HST3								
Effective embedment depth	$h_{ef,2}$	[mm]	47-90	60-100	70-125	85-160	101-180	³⁾
Effective embedment depth	$h_{ef,1}$	[mm]	³⁾	³⁾	50-69	³⁾	³⁾	³⁾
Characteristic resistance	$N_{Rk,s,C2}$	[kN]	19,7	32,5	45,1	76,0	124,2	³⁾
Partial safety factor	$\gamma_{Ms,C2}$ ¹⁾	[-]	1,40					³⁾
HST3-R								
Effective embedment depth	$h_{ef,2}$	[mm]	47-90	60-100	70-125	85-160	101-180	³⁾
Characteristic resistance	$N_{Rk,s,C2}$	[kN]	17,7	28,7	42,5	69,4	115,8	³⁾
Partial safety factor	$\gamma_{Ms,C2}$ ¹⁾	[-]	1,40					³⁾
Pullout failure								
HST3								
Effective embedment depth	$h_{ef,2}$	[mm]	47-90	60-100	70-125	85-160	101-180	³⁾
Characteristic resistance	$N_{Rk,p,C2}$	[kN]	3,0	10,4	19,5	27,0	35,0	³⁾
Installation safety factor	γ_{inst}	[-]	1,00					³⁾
Effective embedment depth	$h_{ef,1}$	[mm]	³⁾	³⁾	50-69	³⁾	³⁾	³⁾
Characteristic resistance	$N_{Rk,p,C2}$	[kN]	³⁾	³⁾	11,4	³⁾	³⁾	³⁾
Installation safety factor	γ_{inst}	[-]	1,00					³⁾
HST3-R								
Effective embedment depth	$h_{ef,2}$	[mm]	47-90	60-100	70-125	85-160	101-180	³⁾
Characteristic resistance	$N_{Rk,p,C2}$	[kN]	3,4	10,4	19,5	27,0	35,0	³⁾
Installation safety factor	γ_{inst}	[-]	1,00					³⁾
Concrete cone failure²⁾								
HST3 and HST3-R								
Effective embedment depth	$h_{ef,2}$	[mm]	47-90	60-100	70-125	85-160	101-180	³⁾
Effective embedment depth	$h_{ef,1}$	[mm]	³⁾	³⁾	50-69	³⁾	³⁾	³⁾
Installation safety factor	γ_{inst}	[-]	1,00					³⁾

¹⁾ In absence of other national regulations

²⁾ For concrete cone failure and splitting failure see EN 1992-4:2018

³⁾ No performance assessed

Hilti metal expansion anchor HST, HST-R, HST-HCR, HST3, HST3-R

Performances

Characteristic tension resistance for performance category C2

Annex C20

Table C14 continued

			M8	M10	M12	M16	M20	M24
Splitting failure ²⁾								
HST3 and HST3-R								
Effective embedment depth	$h_{ef,2}$	[mm]	47-90	60-100	70-125	85-160	101-180	³⁾
Effective embedment depth	$h_{ef,1}$	[mm]	³⁾	³⁾	50-69	³⁾	³⁾	³⁾
Installation safety factor	γ_{inst}	[-]	1,00					³⁾

¹⁾ In absence of other national regulations

²⁾ For concrete cone failure and splitting failure see EN 1992-4:2018

³⁾ No performance assessed

Table C15: Displacements under tension loads for seismic loading for Hilti metal expansion anchor HST3 and HST3-R, performance category C2

			M8	M10	M12	M16	M20	M24
HST3 and HST3-R								
Effective embedment depth	$h_{ef,2}$	[mm]	47-90	60-100	70-125	85-160	101-180	¹⁾
Displacement DLS	$\delta_{N,C2(DLS)}$	[mm]	2,7	3,9	5,2	5,2	6,9	¹⁾
Displacement ULS	$\delta_{N,C2(ULS)}$	[mm]	10,5	13,7	13,9	11,9	18,4	¹⁾
HST3								
Effective embedment depth	$h_{ef,1}$	[mm]	¹⁾	¹⁾	50-69	¹⁾	¹⁾	¹⁾
Displacement DLS	$\delta_{N,C2(DLS)}$	[mm]	¹⁾	¹⁾	1,2	¹⁾	¹⁾	¹⁾
Displacement ULS	$\delta_{N,C2(ULS)}$	[mm]	¹⁾	¹⁾	2,5	¹⁾	¹⁾	¹⁾

¹⁾ No performance assessed

Hilti metal expansion anchor HST, HST-R, HST-HCR, HST3, HST3-R

Performances

Characteristic tension resistance and displacements under tension loads for performance category C2

Annex C21

Table C16: Characteristic shear resistance for seismic loading for Hilti metal expansion anchor HST and HST-R, performance category C2

			M8	M10	M12	M16	M20	M24
Steel failure								
HST								
Partial safety factor	$\gamma_{Ms,C2}^{1)}$	[-]	3)	1,25			3)	3)
Characteristic resistance	$V_{Rk,s,C2}$	[kN]	3)	14,3	21,0	41,3	3)	3)
Reduction factor according to EN 1992-4:2018 with gap filling	α_{gap}	[-]	3)	1,0			3)	3)
Reduction factor according to EN 1992-4:2018 without gap filling	α_{gap}	[-]	3)	0,5			3)	3)
HST-R								
Partial safety factor	$\gamma_{Ms,C2}^{1)}$	[-]	3)	1,25		1,30	3)	3)
Characteristic resistance	$V_{Rk,s,C2}$	[kN]	3)	12,0	18,0	37,5	3)	3)
Reduction factor according to EN 1992-4:2018 with gap filling	α_{gap}	[-]	3)	1,0			3)	3)
Reduction factor according to EN 1992-4:2018 without gap filling	α_{gap}	[-]	3)	0,5			3)	3)
Concrete pryout failure ²⁾								
HST and HST-R								
Installation safety factor	γ_{inst}	[-]	3)	1,00			3)	3)
Concrete edge failure ²⁾								
HST and HST-R								
Installation safety factor	γ_{inst}	[-]	3)	1,00			3)	3)

¹⁾ In absence of other national regulations

²⁾ For concrete pryout failure and concrete edge failure see EN 1992-4:2018

³⁾ No performance assessed

Table C17: Displacements under shear loads for seismic loading for Hilti metal expansion anchor HST and HST-R, performance category C2

			M8	M10	M12	M16	M20	M24
HST and HST-R								
Displacement DLS	$\delta_{V,C2(DLS)}$	[mm]	1)	4,2	5,3	5,7	1)	1)
Displacement ULS	$\delta_{V,C2(ULS)}$	[mm]	1)	7,5	7,9	8,9	1)	1)

¹⁾ No performance assessed

Hilti metal expansion anchor HST, HST-R, HST-HCR, HST3, HST3-R

Performances

Characteristic shear resistance and displacements under shear loads for performance category C2

Annex C22

Table C18: Characteristic shear resistance for seismic loading for Hilti metal expansion anchor HST3 and HST3-R, performance category C2

		M8	M10	M12	M16	M20	M24	
Steel failure								
HST3								
Partial safety factor	$\gamma_{Ms,C2}^{1)}$ [-]	1,25					3)	
Effective embedment depth	$h_{ef,2}$ [mm]	47-90	60-100	70-125	85-160	101-180	3)	
Installation with Hilti filling set								
Characteristic resistance	$V_{Rk,s,C2}$ [kN]	9,9	19,0	28,6	48,5	84,3	3)	
Reduction factor according to EN 1992-4:2018 with gap filling	α_{gap} [-]	1,0					3)	
Installation without Hilti filling set								
Characteristic resistance	$V_{Rk,s,C2}$ [kN]	9,5	16,1	26,1	42,4	66,9	3)	
Reduction factor according to EN 1992-4:2018 without gap filling	α_{gap} [-]	0,5					3)	
Effective embedment depth	$h_{ef,1}$ [mm]	3)	3)	50-69	3)	3)	3)	
Installation with / without Hilti filling set								
Characteristic resistance	$V_{Rk,s,C2}$ [kN]	3)	3)	15,6	3)	3)	3)	
Reduction factor according to EN 1992-4:2018 with gap filling	α_{gap} [-]	1,0					3)	
Reduction factor according to EN 1992-4:2018 without gap filling	α_{gap} [-]	0,5					3)	
HST3-R								
Partial safety factor	$\gamma_{Ms,C2}^{1)}$ [-]	1,25					3)	
Effective embedment depth	$h_{ef,2}$ [mm]	47-90	60-100	70-125	85-160	101-180	3)	
Installation with Hilti filling set								
Characteristic resistance	$V_{Rk,s,C2}$ [kN]	9,9	17,2	27,6	42,5	67,4	3)	
Reduction factor according to EN 1992-4:2018 with gap filling	α_{gap} [-]	1,0					3)	
Installation without Hilti filling set								
Characteristic resistance	$V_{Rk,s,C2}$ [kN]	8,1	15,7	22,4	42,6	49,5	3)	
Reduction factor according to EN 1992-4:2018 without gap filling	α_{gap} [-]	0,5					3)	

Hilti metal expansion anchor HST, HST-R, HST-HCR, HST3, HST3-R

Performances

Characteristic shear resistance and displacements under shear loads for performance category C2

Annex C23

Table C19 continued

Concrete pryout failure ²⁾								
HST3 and HST3-R								
Effective embedment depth	$h_{ef,2}$	[mm]	47-90	60-100	70-125	85-160	101-180	³⁾
Effective embedment depth	$h_{ef,1}$	[mm]	³⁾	³⁾	50-69	³⁾	³⁾	³⁾
Installation safety factor	γ_{inst}	[-]	1,00					³⁾
Concrete edge failure ²⁾								
HST3 and HST3-R								
Effective embedment depth	$h_{ef,2}$	[mm]	47-90	60-100	70-125	85-160	101-180	³⁾
Effective embedment depth	$h_{ef,1}$	[mm]	³⁾	³⁾	50-69	³⁾	³⁾	³⁾
Installation safety factor	γ_{inst}	[-]	1,00					³⁾

¹⁾ In absence of other national regulations

²⁾ For concrete cone failure and splitting failure see EN 1992-4:2018

³⁾ No performance assessed

Hilti metal expansion anchor HST, HST-R, HST-HCR, HST3, HST3-R

Performances

Characteristic shear resistance for performance category C2

Annex C24

Table C20: Displacements under shear loads for seismic loading for Hilti metal expansion anchor HST3 and HST3-R, performance category C2

			M8	M10	M12	M16	M20	M24
HST3								
Effective embedment depth	$h_{ef,2}$	[mm]	47-90	60-100	70-125	85-160	101-180	1)
Displacement DLS	$\delta_{V,C2(DLS)}$	[mm]	3,4	4,0	4,6	4,8	5,2	1)
Displacement DLS using Filling Set	$\delta_{V,C2(DLS)}$	[mm]	1,4	1,6	2,5	1,7	1,9	1)
Displacement ULS	$\delta_{V,C2(ULS)}$	[mm]	4,9	6,2	8,1	8,2	10,0	1)
Displacement ULS using Filling Set	$\delta_{V,C2(ULS)}$	[mm]	4,3	4,4	7,2	3,9	5,3	1)
Effective embedment depth	$h_{ef,1}$	[mm]	1)	1)	50-69	1)	1)	1)
Displacement DLS	$\delta_{V,C2(DLS)}$	[mm]	1)	1)	5,2	1)	1)	1)
Displacement ULS	$\delta_{V,C2(ULS)}$	[mm]	1)	1)	8,4	1)	1)	1)
HST3-R								
Effective embedment depth	$h_{ef,2}$	[mm]	47-90	60-100	70-125	85-160	101-180	1)
Displacement DLS	$\delta_{V,C2(DLS)}$	[mm]	3,5	5,0	6,0	5,8	3,9	1)
Displacement DLS using Filling Set	$\delta_{V,C2(DLS)}$	[mm]	1,6	1,6	2,0	1,9	2,2	1)
Displacement ULS	$\delta_{V,C2(ULS)}$	[mm]	7,5	9,1	10,1	12,3	7,0	1)
Displacement ULS using Filling Set	$\delta_{V,C2(ULS)}$	[mm]	5,0	7,6	6,8	4,7	5,8	1)

1) No performance assessed

Hilti metal expansion anchor HST, HST-R, HST-HCR, HST3, HST3-R

Performances
Displacements under shear loads for performance category C2

Annex C25

Table C21: Characteristic tension resistance under fire exposure for Hilti metal expansion anchor HST, HST-R and HST-HCR in cracked and uncracked concrete

				M8	M10	M12	M16	M20 ¹⁾	M24 ¹⁾
Steel failure									
HST									
Characteristic resistance	R30	$N_{Rk,s,fi}$	[kN]	0,9	2,5	5,0	9,0	15,0	20,0
	R60	$N_{Rk,s,fi}$	[kN]	0,7	1,5	3,5	6,0	10,0	15,0
	R90	$N_{Rk,s,fi}$	[kN]	0,6	1,0	2,0	3,5	6,0	8,0
	R120	$N_{Rk,s,fi}$	[kN]	0,5	0,7	1,0	2,0	3,5	5,0
HST-R and HST HCR									
Characteristic resistance	R30	$N_{Rk,s,fi}$	[kN]	4,9	11,8	17,2	32,0	49,9	71,9
	R60	$N_{Rk,s,fi}$	[kN]	3,6	8,4	12,2	22,8	35,5	51,2
	R90	$N_{Rk,s,fi}$	[kN]	2,4	5,0	7,3	13,5	21,1	30,4
	R120	$N_{Rk,s,fi}$	[kN]	1,7	3,3	4,8	8,9	13,9	20,0
Pullout failure									
HST									
Characteristic resistance in concrete $\geq C20/25$	R30	$N_{Rk,p,fi}$	[kN]	1,3	2,3	3,0	5,0	7,5	10,0
	R60	$N_{Rk,p,fi}$	[kN]						
	R90	$N_{Rk,p,fi}$	[kN]						
	R120	$N_{Rk,p,fi}$	[kN]	1,0	1,8	2,4	4,0	6,0	8,0
HST-R and HST-HCR									
Characteristic resistance in concrete $\geq C20/25$	R30	$N_{Rk,p,fi}$	[kN]	1,3	2,3	3,0	6,3	7,5	10,0
	R60	$N_{Rk,p,fi}$	[kN]						
	R90	$N_{Rk,p,fi}$	[kN]						
	R120	$N_{Rk,p,fi}$	[kN]	1,0	1,8	2,4	5,0	6,0	8,0

¹⁾ Only HST and HST-R

In absence of other national regulations the partial safety factor for resistance under fire exposure $\gamma_{M,fi} = 1,0$ is recommended.

Hilti metal expansion anchor HST, HST-R, HST-HCR, HST3, HST3-R

Performances

Characteristic values of resistance under tension loading under fire exposure in cracked and uncracked concrete

Annex C26

Table C21 continued

				M8	M10	M12	M16	M20 ¹⁾	M24 ¹⁾
Concrete cone failure									
HST, HST-R and HST-HCR									
Characteristic resistance in concrete \geq C20/25	R30	$N^0_{RK,c,fi}$	[kN]	2,7	5,0	7,4	11,0	18,5	31,4
	R60	$N^0_{RK,c,fi}$	[kN]						
	R90	$N^0_{RK,c,fi}$	[kN]	2,2	4,0	5,9	8,8	14,8	25,2
	R120	$N^0_{RK,c,fi}$	[kN]						

¹⁾ Only HST and HST-R

In absence of other national regulations the partial safety factor for resistance under fire exposure $\gamma_{M,fi} = 1,0$ is recommended.

Hilti metal expansion anchor HST, HST-R, HST-HCR, HST3, HST3-R

Performances

Characteristic values of resistance under tension loading under fire exposure in cracked and uncracked concrete

Annex C27

Table C22: Characteristic tension resistance under fire exposure for Hilti metal expansion anchor HST3 and HST3-R in cracked and uncracked concrete

			M8	M10	M12	M16	M20	M24
Steel failure								
HST3								
Effective embedment depth	$h_{ef,2}$	[mm]	47-90	60-100	70-125	85-160	101-180	125
Characteristic resistance	R30	$N_{Rk,s,fi}$ [kN]	0,9	2,4	5,2	9,7	15,2	21,9
	R60	$N_{Rk,s,fi}$ [kN]	0,8	1,8	3,7	6,8	10,6	15,3
	R90	$N_{Rk,s,fi}$ [kN]	0,7	1,2	2,1	3,9	6,0	8,7
	R120	$N_{Rk,s,fi}$ [kN]	0,6	0,9	1,3	2,4	3,8	5,4
HST3-R								
Effective embedment depth	$h_{ef,2}$	[mm]	47-90	60-100	70-125	85-160	101-180	125
Characteristic resistance	R30	$N_{Rk,s,fi}$ [kN]	4,9	11,8	17,1	31,9	49,8	71,8
	R60	$N_{Rk,s,fi}$ [kN]	3,6	8,4	12,2	22,8	35,5	51,2
	R90	$N_{Rk,s,fi}$ [kN]	2,4	5,0	7,3	13,6	21,2	30,6
	R120	$N_{Rk,s,fi}$ [kN]	1,7	3,3	4,8	9,0	14,1	20,3
HST3								
Effective embedment depth	$h_{ef,1}$	[mm]	1)	40-59	50-69	65-84	1)	1)
Characteristic resistance	R30	$N_{Rk,s,fi}$ [kN]	1)	1,5	2,3	4,4	1)	1)
	R60	$N_{Rk,s,fi}$ [kN]	1)	1,2	1,7	3,2	1)	1)
	R90	$N_{Rk,s,fi}$ [kN]	1)	0,9	1,1	2,1	1)	1)
	R120	$N_{Rk,s,fi}$ [kN]	1)	0,8	0,8	1,5	1)	1)
HST3-R								
Effective embedment depth	$h_{ef,1}$	[mm]	1)	40-59	50-69	65-84	1)	1)
Characteristic resistance	R30	$N_{Rk,s,fi}$ [kN]	1)	5,2	9,1	16,9	1)	1)
	R60	$N_{Rk,s,fi}$ [kN]	1)	3,7	6,8	12,6	1)	1)
	R90	$N_{Rk,s,fi}$ [kN]	1)	2,5	4,5	8,4	1)	1)
	R120	$N_{Rk,s,fi}$ [kN]	1)	2,0	3,3	6,2	1)	1)

1) No performance assessed

In absence of other national regulations the partial safety factor for resistance under fire exposure $\gamma_{M,fi} = 1,0$ is recommended.

Hilti metal expansion anchor HST, HST-R, HST-HCR, HST3, HST3-R

Performances

Characteristic values of resistance under tension loading under fire exposure in cracked and uncracked concrete

Annex C28

Table C22 continued

			M8	M10	M12	M16	M20	M24
Pullout failure								
HST3 and HST3-R								
Effective embedment depth	$h_{ef,2}$	[mm]	47-90	60-100	70-125	85-160	101-180	125
Characteristic resistance in concrete $\geq C20/25$	R30	$N_{Rk,p,fi}$ [kN]	1,9	3,0	5,0	7,1	9,1	12,6
	R60	$N_{Rk,p,fi}$ [kN]						
	R90	$N_{Rk,p,fi}$ [kN]						
	R120	$N_{Rk,p,fi}$ [kN]						
HST3 and HST3-R								
Effective embedment depth	$h_{ef,1}$	[mm]	1)	40-59	50-69	65-84	1)	1)
Characteristic resistance in concrete $\geq C20/25$	R30	$N_{Rk,p,fi}$ [kN]	1)	2,3	3,2	4,7	1)	1)
	R60	$N_{Rk,p,fi}$ [kN]						
	R90	$N_{Rk,p,fi}$ [kN]						
	R120	$N_{Rk,p,fi}$ [kN]						

1) No performance assessed

In absence of other national regulations the partial safety factor for resistance under fire exposure $\gamma_{M,fi} = 1,0$ is recommended.

Hilti metal expansion anchor HST, HST-R, HST-HCR, HST3, HST3-R

Performances

Characteristic values of resistance under tension loading under fire exposure in cracked and uncracked concrete

Annex C29

Table C22 continued

			M8	M10	M12	M16	M20	M24
Concrete cone failure								
HST3 and HST3-R								
Effective embedment depth	$h_{ef,2}$	[mm]	47-90	60-100	70-125	85-160	101-180	125
Characteristic resistance in concrete \geq C20/25	R30	$N^0_{RK,c,fi}$ [kN]	2,7	5,0	7,4	12,0	18,5	31,4
	R60	$N^0_{RK,c,fi}$ [kN]						
	R90	$N^0_{RK,c,fi}$ [kN]						
	R120	$N^0_{RK,c,fi}$ [kN]						
HST3 and HST3-R								
Effective embedment depth	$h_{ef,1}$	[mm]	1)	40-59	50-69	65-84	1)	1)
Characteristic resistance in concrete \geq C20/25	R30	$N^0_{RK,c,fi}$ [kN]	1)	1,8	3,2	6,1	1)	1)
	R60	$N^0_{RK,c,fi}$ [kN]						
	R90	$N^0_{RK,c,fi}$ [kN]						
	R120	$N^0_{RK,c,fi}$ [kN]						

1) No performance assessed

In absence of other national regulations the partial safety factor for resistance under fire exposure $\gamma_{M,fi} = 1,0$ is recommended.

Hilti metal expansion anchor HST, HST-R, HST-HCR, HST3, HST3-R

Performances

Characteristic values of resistance under tension loading under fire exposure in cracked and uncracked concrete

Annex C30

Table C23: Characteristic shear resistance under fire exposure for Hilti metal expansion anchor HST, HST-R and HST-HCR in cracked and uncracked concrete

				M8	M10	M12	M16	M20 ¹⁾	M24 ¹⁾
Steel failure without lever arm									
HST									
Characteristic resistance	R30	$V_{Rk,s,fi}$	[kN]	0,9	2,5	5,0	9,0	15,0	20,0
	R60	$V_{Rk,s,fi}$	[kN]	0,7	1,5	3,5	6,0	10,0	15,0
	R90	$V_{Rk,s,fi}$	[kN]	0,6	1,0	2,0	3,5	6,0	8,0
	R120	$V_{Rk,s,fi}$	[kN]	0,5	0,7	1,0	2,0	3,5	5,0
HST-R and HST HCR									
Characteristic resistance	R30	$V_{Rk,s,fi}$	[kN]	4,9	11,8	17,2	32,0	49,9	71,9
	R60	$V_{Rk,s,fi}$	[kN]	3,6	8,4	12,2	22,8	35,5	51,2
	R90	$V_{Rk,s,fi}$	[kN]	2,4	5,0	7,3	13,5	21,1	30,4
	R120	$V_{Rk,s,fi}$	[kN]	1,7	3,3	4,8	8,9	13,9	20,0
Steel failure with lever arm									
HST									
Characteristic resistance	R30	$M^0_{Rk,s,fi}$	[Nm]	1,0	3,3	8,1	20,6	40,2	69,5
	R60	$M^0_{Rk,s,fi}$	[Nm]	0,8	2,4	5,7	14,4	28,1	48,6
	R90	$M^0_{Rk,s,fi}$	[Nm]	0,7	1,6	3,2	8,2	16,0	27,7
	R120	$M^0_{Rk,s,fi}$	[Nm]	0,6	1,2	2,0	5,1	9,9	17,2
HST-R and HST HCR									
Characteristic resistance	R30	$M^0_{Rk,s,fi}$	[Nm]	5,0	15,2	26,6	67,7	132,3	228,6
	R60	$M^0_{Rk,s,fi}$	[Nm]	3,7	10,8	19,0	48,2	94,1	162,6
	R90	$M^0_{Rk,s,fi}$	[Nm]	2,4	6,4	11,3	28,6	55,9	96,6
	R120	$M^0_{Rk,s,fi}$	[Nm]	1,8	4,2	7,4	18,9	36,8	63,7

¹⁾ Only HST and HST-R

¹⁾ No performance assessed

In absence of other national regulations the partial safety factor for resistance under fire exposure $\gamma_{M,fi} = 1,0$ is recommended.

Hilti metal expansion anchor HST, HST-R, HST-HCR, HST3, HST3-R

Performances

Characteristic values of resistance under shear loading under fire exposure in cracked and uncracked concrete

Annex C31

Table C23 continued

				M8	M10	M12	M16	M20 ¹⁾	M24 ¹⁾
Concrete pryout failure									
HST, HST-R and HST-HCR									
Pryout factor	k_8	[-]		2,00	2,00	2,20	2,50	2,50	2,50
Characteristic resistance in concrete \geq C20/25	R30	$V_{Rk,cp,fi}$	[kN]	5,4	10,0	16,0	27,2	49,4	84,5
	R60	$V_{Rk,cp,fi}$	[kN]						
	R90	$V_{Rk,cp,fi}$	[kN]						
	R120	$V_{Rk,cp,fi}$	[kN]						
Concrete edge failure									
HST, HST-R and HST-HCR									
The initial value $V_{Rk,c,fi}^0$ of the characteristic resistance in concrete C20/25 to C50/60 under fire exposure may be determined by: $V_{Rk,c,fi}^0 = 0,25 \times V_{Rk,c}^0$ (\leq R90) $V_{Rk,c,fi}^0 = 0,20 \times V_{Rk,c}^0$ (R120) with $V_{Rk,c}^0$ initial value of the characteristic resistance in cracked concrete C20/25 under normal temperature.									

¹⁾ Only HST and HST-R

¹⁾ No performance assessed

In absence of other national regulations the partial safety factor for resistance under fire exposure $\gamma_{M,fi} = 1,0$ is recommended.

Hilti metal expansion anchor HST, HST-R, HST-HCR, HST3, HST3-R

Performances

Characteristic values of resistance under shear loading under fire exposure in cracked and uncracked concrete

Annex C32

Table C24: Characteristic shear resistance under fire exposure for Hilti metal expansion anchor HST3 and HST3-R in cracked and uncracked concrete

			M8	M10	M12	M16	M20	M24
Steel failure without lever arm								
HST3								
Effective embedment depth	$h_{ef,2}$	[mm]	47-90	60-100	70-125	85-160	101-180	125
Characteristic resistance	R30	$V_{Rk,s,fi}$ [kN]	0,9	2,4	5,2	9,7	15,2	21,9
	R60	$V_{Rk,s,fi}$ [kN]	0,8	1,8	3,7	6,8	10,6	15,3
	R90	$V_{Rk,s,fi}$ [kN]	0,7	1,2	2,1	3,9	6,0	8,7
	R120	$V_{Rk,s,fi}$ [kN]	0,6	0,9	1,3	2,4	3,8	5,4
HST3-R								
Effective embedment depth	$h_{ef,2}$	[mm]	47-90	60-100	70-125	85-160	101-180	125
Characteristic resistance	R30	$V_{Rk,s,fi}$ [kN]	4,9	11,8	17,1	31,9	49,8	71,8
	R60	$V_{Rk,s,fi}$ [kN]	3,6	8,4	12,2	22,8	35,5	51,2
	R90	$V_{Rk,s,fi}$ [kN]	2,4	5,0	7,3	13,6	21,2	30,6
	R120	$V_{Rk,s,fi}$ [kN]	1,7	3,3	4,8	9,0	14,1	20,3
HST3								
Effective embedment depth	$h_{ef,1}$	[mm]	1)	40-59	50-69	65-84	1)	1)
Characteristic resistance	R30	$V_{Rk,s,fi}$ [kN]	1)	1,5	2,3	4,4	1)	1)
	R60	$V_{Rk,s,fi}$ [kN]	1)	1,2	1,7	3,2	1)	1)
	R90	$V_{Rk,s,fi}$ [kN]	1)	0,9	1,1	2,1	1)	1)
	R120	$V_{Rk,s,fi}$ [kN]	1)	0,8	0,8	1,5	1)	1)
HST3-R								
Effective embedment depth	$h_{ef,1}$	[mm]	1)	40-59	50-69	65-84	1)	1)
Characteristic resistance	R30	$V_{Rk,s,fi}$ [kN]	1)	5,2	9,1	16,9	1)	1)
	R60	$V_{Rk,s,fi}$ [kN]	1)	3,7	6,8	12,6	1)	1)
	R90	$V_{Rk,s,fi}$ [kN]	1)	2,5	4,5	8,4	1)	1)
	R120	$V_{Rk,s,fi}$ [kN]	1)	2,0	3,3	6,2	1)	1)

1) No performance assessed

In absence of other national regulations the partial safety factor for resistance under fire exposure $\gamma_{M,fi} = 1,0$ is recommended.

Hilti metal expansion anchor HST, HST-R, HST-HCR, HST3, HST3-R

Performances

Characteristic values of resistance under shear loading under fire exposure in cracked and uncracked concrete

Annex C33

Table C24 continued

			M8	M10	M12	M16	M20	M24
Steel failure with lever arm								
HST3								
Effective embedment depth	$h_{ef,2}$	[mm]	47-90	60-100	70-125	85-160	101-180	125
Characteristic resistance	R30	$M^0_{Rk,s,fi}$ [Nm]	0,9	3,1	8,1	20,6	40,2	69,5
	R60	$M^0_{Rk,s,fi}$ [Nm]	0,8	2,4	5,7	14,4	28,1	48,6
	R90	$M^0_{Rk,s,fi}$ [Nm]	0,7	1,6	3,2	8,2	16,0	27,7
	R120	$M^0_{Rk,s,fi}$ [Nm]	0,6	1,2	2,0	5,1	10,0	17,2
HST3-R								
Effective embedment depth	$h_{ef,2}$	[mm]	47-90	60-100	70-125	85-160	101-180	125
Characteristic resistance	R30	$M^0_{Rk,s,fi}$ [Nm]	5,0	15,2	26,6	67,6	132,0	228,2
	R60	$M^0_{Rk,s,fi}$ [Nm]	3,7	10,8	19,0	48,2	94,1	162,7
	R90	$M^0_{Rk,s,fi}$ [Nm]	2,4	6,5	11,3	28,8	56,3	97,2
	R120	$M^0_{Rk,s,fi}$ [Nm]	1,8	4,3	7,5	19,1	37,3	64,5
HST3								
Effective embedment depth	$h_{ef,1}$	[mm]	1)	40-59	50-69	65-84	1)	1)
Characteristic resistance	R30	$M^0_{Rk,s,fi}$ [Nm]	1)	2,0	3,6	9,3	1)	1)
	R60	$M^0_{Rk,s,fi}$ [Nm]	1)	1,6	2,7	6,9	1)	1)
	R90	$M^0_{Rk,s,fi}$ [Nm]	1)	1,2	1,8	4,5	1)	1)
	R120	$M^0_{Rk,s,fi}$ [Nm]	1)	1,0	1,3	3,3	1)	1)
HST3-R								
Effective embedment depth	$h_{ef,1}$	[mm]	1)	40-59	50-69	65-84	1)	1)
Characteristic resistance	R30	$M^0_{Rk,s,fi}$ [Nm]	1)	6,7	14,1	35,9	1)	1)
	R60	$M^0_{Rk,s,fi}$ [Nm]	1)	4,8	10,5	26,8	1)	1)
	R90	$M^0_{Rk,s,fi}$ [Nm]	1)	3,2	7,0	17,7	1)	1)
	R120	$M^0_{Rk,s,fi}$ [Nm]	1)	2,6	5,2	13,2	1)	1)

1) No performance assessed

In absence of other national regulations the partial safety factor for resistance under fire exposure $\gamma_{M,fi} = 1,0$ is recommended.

Hilti metal expansion anchor HST, HST-R, HST-HCR, HST3, HST3-R

Performances

Characteristic values of resistance under shear loading under fire exposure in cracked and uncracked concrete

Annex C34

Table C24 continued

			M8	M10	M12	M16	M20	M24
Concrete pryout failure								
HST3 and HST3-R								
Effective embedment depth	$h_{ef,2}$	[mm]	47-90	60-100	70-125	85-160	101-180	125
Pryout factor	k_8	[-]	2,62	2,67	2,78	3,41	3,20	2,50
Characteristic resistance in concrete \geq C20/25	R30	$V_{Rk,cp,fi}$ [kN]	7,0	13,0	20,7	40,8	37,0	62,8
	R60	$V_{Rk,cp,fi}$ [kN]						
	R90	$V_{Rk,cp,fi}$ [kN]	5,7	10,4	16,5	32,6	29,6	50,4
	R120	$V_{Rk,cp,fi}$ [kN]						
HST3 and HST3-R								
Effective embedment depth	$h_{ef,1}$	[mm]	1)	40-59	50-69	65-84	1)	1)
Pryout factor	k_8	[-]	1)	2,67	2,78	3,41	1)	1)
Characteristic resistance in concrete \geq C20/25	R30	$V_{Rk,cp,fi}$ [kN]	1)	4,7	8,9	20,8	1)	1)
	R60	$V_{Rk,cp,fi}$ [kN]						
	R90	$V_{Rk,cp,fi}$ [kN]	1)	3,8	7,1	16,7	1)	1)
	R120	$V_{Rk,cp,fi}$ [kN]						
Concrete edge failure								
HST3 and HST3-R								
The initial value $V_{Rk,c,fi}^0$ of the characteristic resistance in concrete C20/25 to C50/60 under fire exposure may be determined by: $V_{Rk,c,fi}^0 = 0,25 \times V_{Rk,c}^0$ (\leq R90) $V_{Rk,c,fi}^0 = 0,20 \times V_{Rk,c}^0$ (R120) with $V_{Rk,c}^0$ initial value of the characteristic resistance in cracked concrete C20/25 under normal temperature.								

1) No performance assessed

In absence of other national regulations the partial safety factor for resistance under fire exposure $\gamma_{M,fi} = 1,0$ is recommended.

Hilti metal expansion anchor HST, HST-R, HST-HCR, HST3, HST3-R

Performances

Characteristic values of resistance under shear loading under fire exposure in cracked and uncracked concrete

Annex C35