



## European Technical Assessment

**ETA-16/0143**  
**du 14/05/2019**

English translation prepared by CSTB - Original version in French language

### General Part

Nom commercial:  
*Trade name:*

**Injection system Hilti HIT-RE 500 V3**

Famille de produit:  
*Product family:*

Cheville à scellement avec tige filetée, fers à béton, douille taraudée HIS-(R)N et cheville de traction Hilti HZA(-R) pour usage dans le béton.

**Bonded fastener with threaded rods, rebar, internally threaded sleeve HIS-(R)N and Hilti tension anchor HZA(-R) for use in concrete.**

Titulaire:  
*Manufacturer:*

Hilti Corporation  
Feldkircherstrasse 100  
FL-9494 Schaan  
Principality of Liechtenstein

Usine de fabrication:  
*Manufacturing plants:*

Hilti Plant

Cette évaluation contient:  
*This Assessment contains:*

49 pages incluant 46 pages d'annexes qui font partie intégrante de cette évaluation  
*49 pages including 46 pages of annexes which form an integral part of this assessment*

Base de l'ETE:  
*Basis of ETA:*

EAD 330499-01-0601

Cette évaluation remplace:  
*This Assessment replaces:*

ETE-16/0143 du 12/07/2017  
*ETA-16/0143 dated 12/07/2017*

*Translations of this European Technical Assessment in other languages shall fully correspond to the original issued document and should be identified as such. Communication of this European Technical Assessment, including transmission by electronic means, shall be in full. However, partial reproduction may be made, with the written consent of the issuing Technical Assessment Body. Any partial reproduction has to be identified as such.*

## Specific Part

### 1 Technical description of the product

The Injection system Hilti HIT-RE 500 V3 is a bonded fastener consisting of a foil pack with injection mortar Hilti HIT-RE 500 V3 and a steel element.

These steel elements are:

- a threaded rod Hilti HAS-U, Hilti HIT-V, Hilti meter rod AM 8.8 or a commercial threaded rod with washer and hexagon nut in the range of M8 to M30
- a rebar in the range of  $\phi 8$  to  $\phi 32$
- a Hilti Tension Anchor HZA in the range of M12 to M27 or HZA-R in the range of M12 to M24.
- an internal threaded sleeve HIS-(R)N in the range M8 to M20

The steel element is placed into a drilled hole filled with injection mortar and is anchored via the bond between metal part, injection mortar and concrete.

The illustration and the description of the product are given in Annexes A.

### 2 Specification of the intended use

The performances given in Section 3 are only valid if the fastener is used in compliance with the specifications and conditions given in Annexes B.

The provisions made in this European technical assessment are based on an assumed working life of the fastener of 50 years and 100 years. The indications given on the working life cannot be interpreted as a guarantee given by the producer, but are to be regarded only as a means for choosing the right products in relation to the expected economically reasonable working life of the works.

### 3 Performance of the product

#### 3.1 Mechanical resistance and stability (BWR 1)

Essential characteristic	Performance
Characteristic resistance for static and quasi static loads, Displacements	See Annex C1 to C16
Characteristic resistance for seismic performance category C1	See Annex C17 to C20
Characteristic resistance for seismic performance category C2, Displacements	See Annex C21

#### 3.2 Safety in case of fire (BWR 2)

Essential characteristic	Performance
Reaction to fire	Anchorage satisfy requirements for Class A1
Resistance to fire	No performance assessed

#### 3.3 Hygiene, health and the environment (BWR 3)

Regarding dangerous substances contained in this European technical approval, there may be requirements applicable to the products falling within its scope (e.g. transposed European legislation and national laws, regulations and administrative provisions). In order to meet the provisions of the Construction Products Directive, these requirements need also to be complied with, when and where they apply.

### 3.4 Safety in use (BWR 4)

For Basic requirement Safety in use the same criteria are valid as for Basic Requirement Mechanical resistance and stability.

### 3.5 Protection against noise (BWR 5)

Not relevant.

### 3.6 Energy economy and heat retention (BWR 6)

Not relevant.

### 3.7 Sustainable use of natural resources (BWR 7)

For the sustainable use of natural resources no performance was determined for this product.

### 3.8 General aspects relating to fitness for use

Durability and Serviceability are only ensured if the specifications of intended use according to Annex B1 are kept.

## 4 Assessment and verification of constancy of performance (AVCP)

According to the Decision 96/582/EC of the European Commission<sup>1</sup>, as amended, the system of assessment and verification of constancy of performance (see Annex V to Regulation (EU) No 305/2011) given in the following table apply.

Product	Intended use	Level or class	System
Metal fasteners for use in concrete	For fixing and/or supporting to concrete, structural elements (which contributes to the stability of the works) or heavy units	—	1

## 5 Technical details necessary for the implementation of the AVCP system

Technical details necessary for the implementation of the Assessment and verification of constancy of performance (AVCP) system are laid down in the control plan deposited at Centre Scientifique et Technique du Bâtiment.

The manufacturer shall, on the basis of a contract, involve a notified body approved in the field of fasteners for issuing the certificate of conformity CE based on the control plan.

### The original French version is signed by

Charles Baloche  
Technical Director

---

<sup>1</sup> Official Journal of the European Communities L 254 of 08.10.1996

### Installed condition

**Figure A1:**

Threaded rod, HAS-U-..., HIT-V-..., AM...8.8 ...

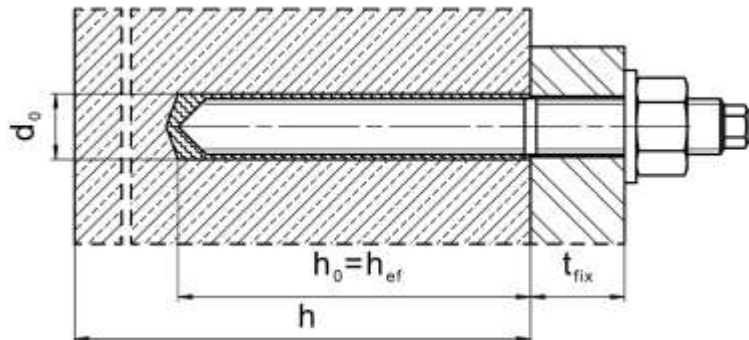

**Figure A2:**

Threaded rod, HAS-U-..., HIT-V-..., AM...8.8, with Hilti Filling Set...

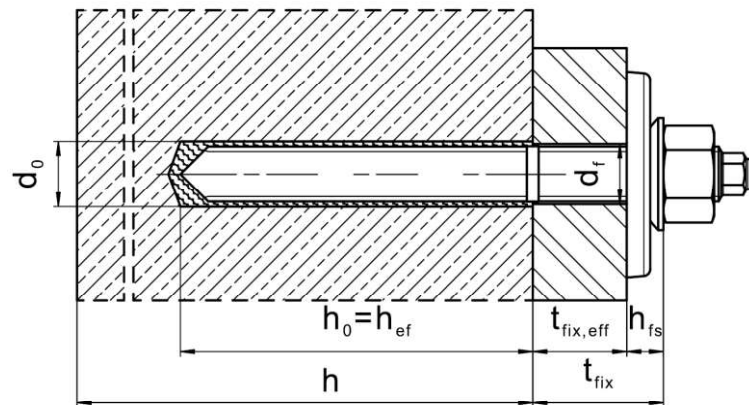

**Figure A3:**

Internally threaded sleeve HIS-(R)N

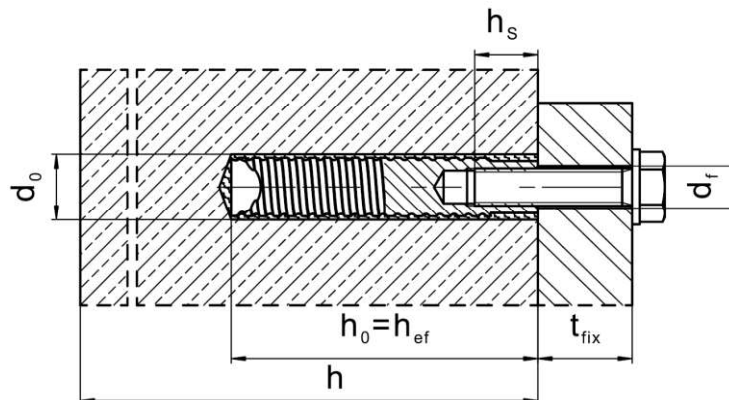

Injection system Hilti HIT-RE 500 V3

Product  
Installed condition

Annex A1

**Installed condition**

**Figure A4:**  
Reinforcing bar (rebar)

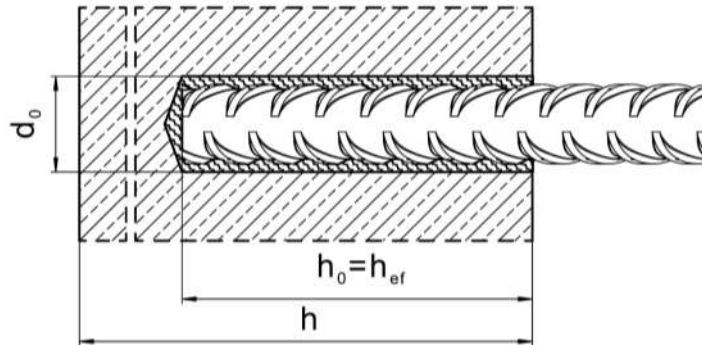

**Injection system Hilti HIT-RE 500 V3**

**Product**  
Installed condition

**Annex A2**

**Product description: Injection mortar and steel elements**

**Injection mortar Hilti HIT-RE 500 V3:** epoxy resin system with aggregate

330 ml, 500 ml and 1400 ml

Marking:  
 HILTI HIT  
 Product name  
 Production time and line  
 Expiry date mm/yyyy



Product name: "Hilti HIT-RE 500 V3"

**Static mixer Hilti HIT-RE-M**



**Steel elements**



**HAS-U-...: M8 to M30**

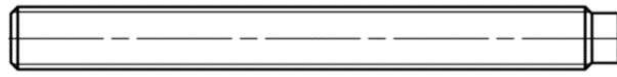
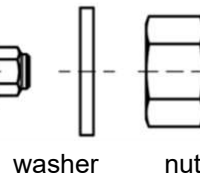

**HIT-V-...: M8 to M30**

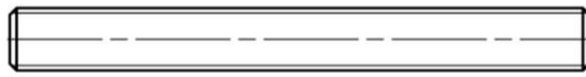
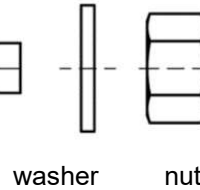

**Threaded rod : M8 to M30**

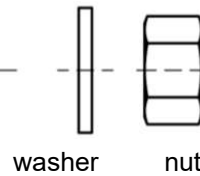

**Hilti meter rod AM 8.8, electroplated zinc coated M8 to M30, 1m to 3m**

**Hilti AM HDG 8.8 meter rod hot dip galvanized: M8 to M30, 1m to 3m**

Commercial standard threaded rod with:

- Materials and mechanical properties according to Table A1.
- Inspection certificate 3.1 according to EN 10204:2004. The document shall be stored.
- Marking of embedment depth.

**Injection system Hilti HIT-RE 500 V3**

**Product**

Injection mortar / Static mixer / Steel elements.

**Annex A3**

**Steel elements**

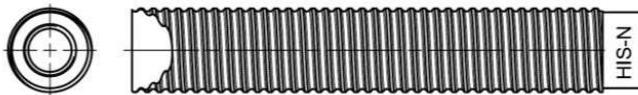

**Internally threaded sleeve HIS-(R)N M8 to M20**

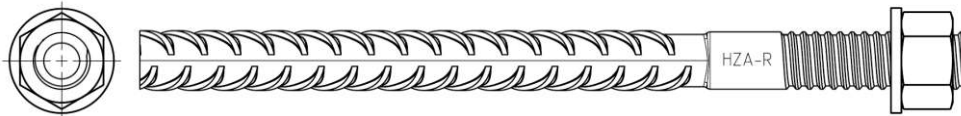

**Hilti Tension Anchor HZA M12 to M27 and HZA-R M12 to M24**



**Reinforcing bar (rebar):  $\phi$  8 to  $\phi$  32**

- Materials and mechanical properties according to Table A1.
- Dimensions according to Annex B6

**Hilti Filling Set to fill the annular gap between anchor and fixture**

Sealing washer

Spherical washer

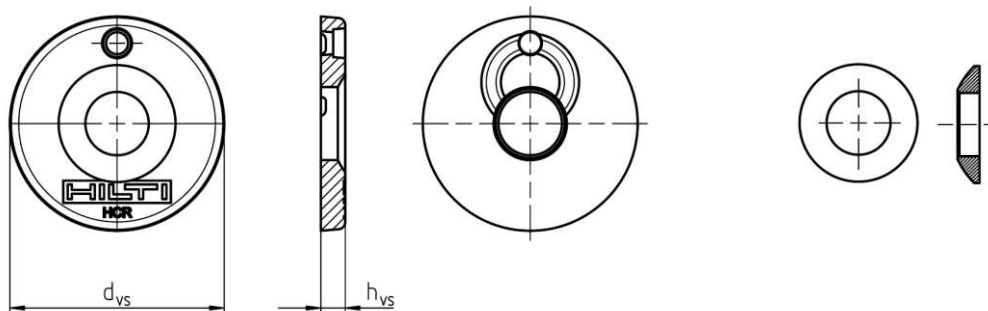

Hilti Filling Set		M16	M20	M24
Diameter of sealing washer	d <sub>vs</sub> [mm]	56	60	70
Thickness of sealing washer	h <sub>vs</sub> [mm]	6		
Thickness of Hilti Filling Set	h <sub>fs</sub> [mm]	11	13	15

**Injection system Hilti HIT-RE 500 V3**

**Product**  
 Injection mortar / Static mixer / Steel elements.

**Annex A4**

**Table A1: Materials**

Designation	Material
<b>Reinforcing bars (rebars)</b>	
Rebar EN 1992-1-1:2004 and AC:2010, Annex C	Bars and de-coiled rods class B or C with $f_{yk}$ and $k$ according to NDP or NCL of EN 1992-1-1/NA:2013 $f_{uk} = f_{tk} = k \cdot f_{yk}$
<b>Metal parts made of zinc coated steel</b>	
Threaded rod, HAS-U-5.8 (F), HIT-V-5.8 (F)	Strength class 5.8, $f_{uk} = 500 \text{ N/mm}^2$ , $f_{yk} = 400 \text{ N/mm}^2$ Elongation at fracture ( $l_0 = 5d$ ) > 8% ductile Electroplated zinc coated $\geq 5 \mu\text{m}$ , (F) hot dip galvanized $\geq 45 \mu\text{m}$
Threaded rod, HAS-U-8.8 (F), HIT-V-8.8 (F)	Strength class 8.8, $f_{uk} = 800 \text{ N/mm}^2$ , $f_{yk} = 640 \text{ N/mm}^2$ Elongation at fracture ( $l_0 = 5d$ ) > 12% ductile Electroplated zinc coated $\geq 5 \mu\text{m}$ , (F) hot dip galvanized $\geq 45 \mu\text{m}$
Hilti Meter rod, AM 8.8 (HDG)	Strength class 8.8, $f_{uk} = 800 \text{ N/mm}^2$ , $f_{yk} = 640 \text{ N/mm}^2$ Elongation at fracture ( $l_0 = 5d$ ) > 12% ductile, Electroplated zinc coated $\geq 5 \mu\text{m}$ , (HDG) hot dip galvanized $\geq 45 \mu\text{m}$
Hilti tension anchor HZA	Round steel with threaded part: electroplated zinc coated $\geq 5 \mu\text{m}$ Rebar: Bars class B according to NDP or NCL of EN 1992-1-1/NA
Internally threaded sleeve HIS-N	Electroplated zinc coated $\geq 5 \mu\text{m}$
Washer	Electroplated zinc coated $\geq 5 \mu\text{m}$ , hot dip galvanized $\geq 45 \mu\text{m}$
Nut	Strength class of nut adapted to strength class of threaded rod. Electroplated zinc coated $\geq 5 \mu\text{m}$ , hot dip galvanized $\geq 45 \mu\text{m}$
Hilti Filling Set (F)	Filling washer: Electroplated zinc coated $\geq 5 \mu\text{m}$ , (F) hot dip galvanized $\geq 45 \mu\text{m}$ Spherical washer: Electroplated zinc coated $\geq 5 \mu\text{m}$ , (F) hot dip galvanized $\geq 45 \mu\text{m}$ Lock nut: Electroplated zinc coated $\geq 5 \mu\text{m}$ , (F) hot dip galvanized $\geq 45 \mu\text{m}$
<b>Metal parts made of stainless steel</b>	
Threaded rod, HAS-U-R, HIT-V-R	For $\leq \text{M24}$ : strength class 70, $f_{uk} = 700 \text{ N/mm}^2$ , $f_{yk} = 450 \text{ N/mm}^2$ For $> \text{M24}$ : strength class 50, $f_{uk} = 500 \text{ N/mm}^2$ , $f_{yk} = 210 \text{ N/mm}^2$ Elongation at fracture ( $l_0 = 5d$ ) > 8% ductile Stainless steel A4 according to EN 10088-1:2014, e.g. material 1.4401, 1.4404, 1.4578, 1.4571, 1.4439, 1.4362.
Hilti tension anchor HZA-R	Round steel with threaded part: Stainless steel according to EN 10088-1:2014, e.g. material 1.4404, 1.4362, 1.4571 Rebar: Bars class B according to NDP or NCL of EN 1992-1-1/NA:2013
Internally threaded sleeve HIS-RN	Stainless steel according to EN 10088-1:2014, e.g. material 1.4401, 1.4571
Washer	Stainless steel A4 according to EN 10088-1:2014, e.g. material 1.4401, 1.4404, 1.4578, 1.4571, 1.4439, 1.4362.
Nut	Strength class of nut adapted to strength class of threaded rod. Stainless steel A4 according to EN 10088-1:2014, e.g. material 1.4401, 1.4404, 1.4578, 1.4571, 1.4439, 1.4362.
<b>Metal parts made of high corrosion resistant steel</b>	
Threaded rod, HAS-U-HCR, HIT-V-HCR	For $\leq \text{M20}$ : $f_{uk} = 800 \text{ N/mm}^2$ , $f_{yk} = 640 \text{ N/mm}^2$ For $> \text{M20}$ : $f_{uk} = 700 \text{ N/mm}^2$ , $f_{yk} = 400 \text{ N/mm}^2$ , Elongation at fracture ( $l_0 = 5d$ ) > 8% ductile High corrosion resistant steel according to EN 10088-1:2014, e.g. material 1.4529, 1.4565
Washer	High corrosion resistant steel according to EN 10088-1:2014, e.g. material 1.4529, 1.4565
Nut	Strength class of nut adapted to strength class of threaded rod. High corrosion resistant steel according to EN 10088-1:2014, e.g. material 1.4529, 1.4565

**Injection system Hilti HIT-RE 500 V3**

**Product description**  
Materials.

**Annex A5**

## Specifications of intended use

### Anchorage subject to:

- Static and quasi static loading.
- Seismic performance category C1
- Seismic performance category C2 (HAS-U, HAS-U-F, HIT-V, HIT-V-F, AM, AM-HDG grade 8.8 and commercial standard rod grade 8.8 electroplated zinc coated only, with hammer drilling and hammer drilling with Hilti hollow drill bit TE-CD, TE-YD).

### Base material:

- Reinforced or unreinforced normal weight concrete according to EN 206:2013.
- Strength classes C20/25 to C50/60 according to EN 206:2013.
- Cracked and uncracked concrete.
- Water-filled drill holes for uncracked concrete only

### Temperature in the base material:

- **At installation**  
-5 °C to +40 °C for the standard variation of temperature after installation
- **In-service**  
Temperature range I: -40 °C to +40 °C  
(max. long term temperature +24 °C and max. short term temperature +40 °C)  
Temperature range II: -40 °C to +70 °C  
(max. long term temperature +43 °C and max. short term temperature +70 °C)

### Use conditions (Environmental conditions):

- Structures subject to dry internal conditions (zinc coated steel, stainless steel or high corrosion resistant steel).
- Structures subject to external atmospheric exposure (including industrial and marine environment) and to permanently damp internal conditions, if no particular aggressive conditions exist (stainless steel or high corrosion resistant steel).
- Structures subject to external atmospheric exposure and to permanently damp internal conditions, if other particular aggressive conditions exist (high corrosion resistant steel).  
Note: Particular aggressive conditions are e.g. permanent, alternating immersion in seawater or the splash zone of seawater, chloride atmosphere of indoor swimming pools or atmosphere with extreme chemical pollution (e.g. in desulphurization plants or road tunnels where de-icing products are used).

### Design:

- Anchorages are designed under the responsibility of an engineer experienced in anchorages and concrete work.
- Verifiable calculation notes and drawings are prepared taking account of the loads to be anchored. The position of the anchor is indicated on the design drawings (e. g. position of the anchor relative to reinforcement or to supports, etc.).
- The anchorages are designed in accordance with EN 1992-4:2018 and EOTA Technical Report TR 055. Anchorages under seismic actions shall be positioned outside of critical regions (e.g. plastic hinges) of the concrete structure. Fastening in stand-off installation or with a grout layer under seismic action are not covered in this European technical assessment (ETA).

Injection system Hilti HIT-RE 500 V3

Intended use  
Specifications.

Annex B1

**Installation:**

- Use category:
  - dry or wet concrete (not in water-filled drill holes): for all drilling techniques
  - dry or wet concrete or installation in water-filled drill holes: for hammer drilling only, for uncracked concrete only
- Drilling technique:
  - hammer drilling,
  - hammer drilling with Hilti hollow drill bit TE-CD, TE-YD,
  - diamond coring, for uncracked concrete only,
  - diamond coring with roughening with Hilti roughening tool TE-YRT.
- Installation direction D3: downward, horizontal and upward (e.g. overhead) installation admissible for all elements.
- Anchor installation carried out by appropriately qualified personnel and under the supervision of the person responsible for technical matters of the site.

**Injection system Hilti HIT-RE 500 V3**

**Intended use**  
Specifications.

**Annex B2**

**Table B1: Installation parameters of threaded rod, HAS-U-..., HIT-V-... and AM 8.8**

Threaded rod, HAS-U-..., HIT-V-..., AM...8.8			M8	M10	M12	M16	M20	M24	M27	M30
Diameter of element	d	[mm]	8	10	12	16	20	24	27	30
Nominal diameter of drill bit	d <sub>0</sub>	[mm]	10	12	14	18	22	28	30	35
Effective embedment depth and drill hole depth	h <sub>ef</sub>	[mm]	60 to 160	60 to 200	70 to 240	80 to 320	90 to 400	96 to 480	108 to 540	120 to 600
Maximum diameter of clearance hole in the fixture	d <sub>f</sub>	[mm]	9	12	14	18	22	26	30	33
Thickness of Hilti filling set	h <sub>fs</sub>	[mm]	-	-	-	11	13	15	-	-
Effective fixture thickness with Hilti filling set	t <sub>fix,eff</sub>	[mm]	$t_{fix,eff} = t_{fix} - h_{fs}$							
Minimum thickness of concrete member	h <sub>min</sub>	[mm]	$h_{ef} + 30$ ≥ 100 mm			$h_{ef} + 2 \cdot d_0$				
Maximum torque	T <sub>max</sub>	[Nm]	10	20	40	80	150	200	270	300
Minimum spacing	s <sub>min</sub>	[mm]	40	50	60	75	90	115	120	140
Minimum edge distance	c <sub>min</sub>	[mm]	40	45	45	50	55	60	75	80

**HAS-U-...**

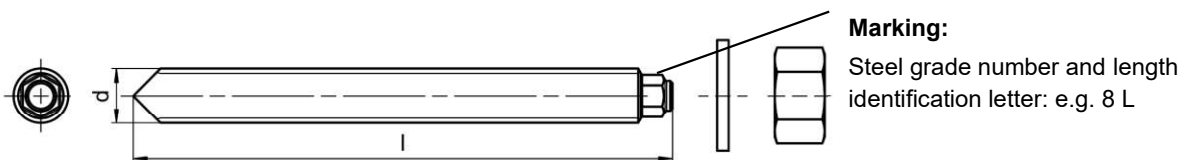

**HIT-V-...**

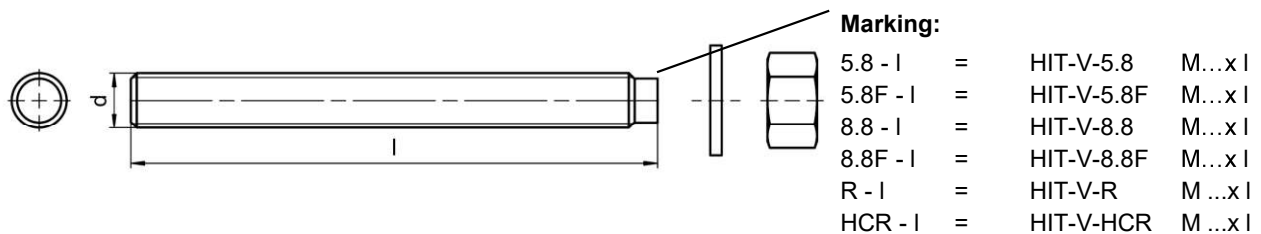

Injection system Hilti HIT-RE 500 V3

**Intended Use**  
 Installation parameters.

**Annex B3**

**Table B2: Installation parameters of internally threaded sleeve HIS-(R)N**

Internally threaded sleeve HIS-(R)N			M8	M10	M12	M16	M20
Outer diameter of sleeve	d	[mm]	12,5	16,5	20,5	25,4	27,6
Nominal diameter of drill bit	d <sub>0</sub>	[mm]	14	18	22	28	32
Effective embedment depth and drill hole depth	h <sub>ef</sub>	[mm]	90	110	125	170	205
Maximum diameter of clearance hole in the fixture <sup>3)</sup>	d <sub>f</sub>	[mm]	9	12	14	18	22
Minimum thickness of concrete member	h <sub>min</sub>	[mm]	120	150	170	230	270
Maximum torque	T <sub>max</sub>	[Nm]	10	20	40	80	150
Thread engagement length min-max	h <sub>s</sub>	[mm]	8-20	10-25	12-30	16-40	20-50
Minimum spacing	s <sub>min</sub>	[mm]	60	75	90	115	130
Minimum edge distance	c <sub>min</sub>	[mm]	40	45	55	65	90

**Internally threaded sleeve HIS-(R)N...**

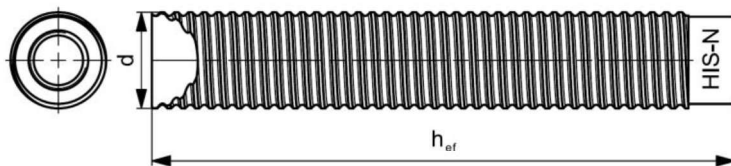

**Marking:**  
 Identifying mark - HILTI and  
 embossing "HIS-N" (for zinc coated steel)  
 embossing "HIS-RN" (for stainless steel)

**Injection system Hilti HIT-RE 500 V3**

**Intended Use**  
 Installation parameters.

**Annex B4**

**Table B3: Installation parameters of Hilti tension anchor HZA-R**

Hilti tension anchor HZA-R			M12	M16	M20	M24
Rebar diameter	$\phi$	[mm]	12	16	20	25
Nominal embedment depth and drill hole depth	$h_{nom} = h_0$	[mm]	170 to 240	180 to 320	190 to 400	200 to 500
Effective embedment depth ( $h_{ef} = h_{nom} - l_e$ )	$h_{ef}$	[mm]	$h_{nom} - 100$			
Length of smooth shaft	$l_e$	[mm]	100			
Nominal diameter of drill bit	$d_0$	[mm]	16	20	25	32
Maximum diameter of clearance hole in the fixture	$d_f$	[mm]	14	18	22	26
Maximum torque	$T_{max}$	[Nm]	40	80	150	200
Minimum thickness of concrete member	$h_{min}$	[mm]	$h_{nom} + 2 \cdot d_0$			
Minimum spacing	$s_{min}$	[mm]	65	80	100	130
Minimum edge distance	$c_{min}$	[mm]	45	50	55	60

**Table B4: Installation parameters of Hilti tension anchor HZA**

Hilti tension anchor HZA			M12	M16	M20	M24	M27
Rebar diameter	$\phi$	[mm]	12	16	20	25	28
Nominal embedment depth and drill hole depth	$h_{nom} = h_0$	[mm]	90 to 240	100 to 320	110 to 400	120 to 500	140 to 560
Effective embedment depth ( $h_{ef} = h_{nom} - l_e$ )	$h_{ef}$	[mm]	$h_{nom} - 20$				
Length of smooth shaft	$l_e$	[mm]	20				
Nominal diameter of drill bit	$d_0$	[mm]	16	20	25	32	35
Maximum diameter of clearance hole in the fixture	$d_f$	[mm]	14	18	22	26	30
Maximum torque	$T_{max}$	[Nm]	40	80	150	200	270
Minimum thickness of concrete member	$h_{min}$	[mm]	$h_{nom} + 2 \cdot d_0$				
Minimum spacing	$s_{min}$	[mm]	65	80	100	130	140
Minimum edge distance	$c_{min}$	[mm]	45	50	55	60	75

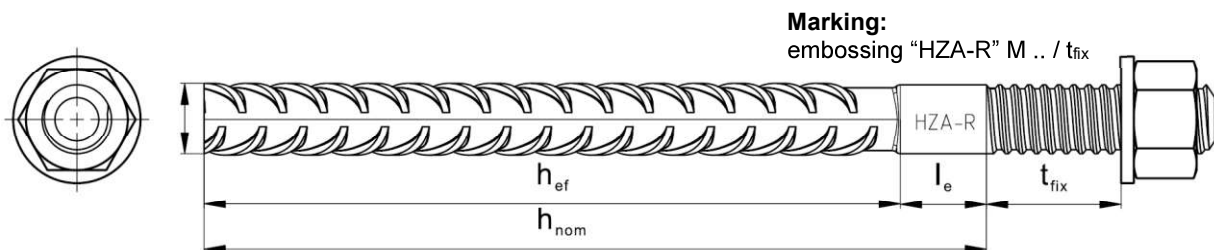

**Injection system Hilti HIT-RE 500 V3**

**Intended Use**  
 Installation parameters.

**Annex B5**

**Table B5: Installation parameters of reinforcing bar (rebar)**

Reinforcing bar (rebar)	$\phi$ 8	$\phi$ 10	$\phi$ 12	$\phi$ 14	$\phi$ 16	$\phi$ 20	$\phi$ 25	$\phi$ 28	$\phi$ 30	$\phi$ 32
Diameter $\phi$ [mm]	8	10	12	14	16	20	25	28	30	32
Effective embedment depth and drill hole depth $h_{ef} = h_0$ [mm]	60 to 160	60 to 200	70 to 240	75 to 280	80 to 320	90 to 400	100 to 500	112 to 560	120 to 600	128 to 640
Nominal diameter of drill bit $d_0$ [mm]	10 <sup>1)</sup> 12 <sup>1)</sup>	12 <sup>1)</sup> 14 <sup>1)</sup>	14 <sup>1)</sup> 16 <sup>1)</sup>	18	20	25	30 <sup>1)</sup> 32 <sup>1)</sup>	35	37	40
Minimum thickness of concrete member $h_{min}$ [mm]	$h_{ef} + 30$ $\geq 100$ mm			$h_{ef} + 2 \cdot d_0$						
Minimum spacing $s_{min}$ [mm]	40	50	60	70	80	100	125	140	150	160
Minimum edge distance $c_{min}$ [mm]	40	45	45	50	50	65	70	75	80	80

<sup>1)</sup> Each of the two given values can be used.

**Reinforcing bar (rebar)**

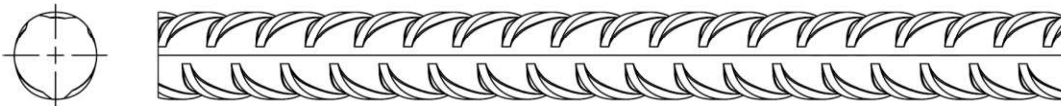

For rebar bolt

- Minimum value of related rib area  $f_{R,min}$  according to EN 1992-1-1:2004+AC:2010.
- Rib height of the bar  $h_{rib}$  shall be in the range  $0,05 \cdot \phi \leq h_{rib} \leq 0,07 \cdot \phi$  ( $\phi$ : Nominal diameter of the bar;  $h_{rib}$ : Rib height of the bar).

**Injection system Hilti HIT-RE 500 V3**

**Intended Use.**  
 Installation parameters

**Annex B7**

**Table B6: Minimum curing time<sup>1)</sup>**

Temperature in the base material T	Maximum working time $t_{work}$	Minimum curing time $t_{cure}^{1)}$
-5 °C to -1 °C	<u>2</u> hours	168 hours
0 °C to 4 °C	<u>2</u> hours	48 hours
5 °C to 9 °C	2 hours	24 hours
10 °C to 14 °C	1,5 hours	16 hours
15 °C to 19 °C	1 hours	12 hours
20 °C to 24 °C	30 min	7 hours
25 °C to 29 °C	20 min	6 hours
30 °C to 34 °C	15 min	5 hours
35 °C to 39 °C	12 min	4,5 hours
40 °C	10 min	4 hours

<sup>1)</sup> The curing time data are valid for dry base material only. In wet base material the curing times must be doubled.

**Injection system Hilti HIT-RE 500 V3**

**Intended Use.**

Maximum working time and minimum curing time



**Annex B8**

**Table B7: Parameters of cleaning and setting tools**

Elements				Drill and clean					Installation
Threaded rod, HAS-U-... HIT-V-... AM...8.8	HIS-(R)N	Rebar	HZA(-R)	Hammer drilling		Diamond coring		Brush	Piston plug
				Hollow drill bit TE-CD, TE-YD			Roughening tool TE-YRT		
Size	Name	Size	Size	d <sub>0</sub> [mm]	d <sub>0</sub> [mm]	d <sub>0</sub> [mm]	d <sub>0</sub> [mm]	HIT-RB	HIT-SZ
M8	-	φ 8	-	10	-	10	-	10	-
M10	-	φ 8, φ 10	-	12	-	12	-	12	12
M12	M8	φ 10, φ 12	-	14	14 <sup>1)</sup>	14	-	14	14
-	-	φ 12	M12	16	16	16	-	16	16
M16	M10	φ 14	-	18	18	18	18	18	18
-	-	φ 16	M16	20	20	20	20	20	20
M20	M12	-	-	22	22	22	22	22	22
-	-	φ 20	M20	25	25	25	25	25	25
M24	M16	-	-	28	28	28	28	28	28
M27	-	-	-	30	-	30	30	30	30
-	M20	φ 25	M24	32	32	32	32	32	32
M30	-	φ 28	M27	35	35	35	35	35	35
-	-	φ 30	-	37	-	37	-	37	37
-	-	φ 32	-	40	-	-	-	40	40
				-	-	42	-	42	42

<sup>1)</sup> To be used in combination with Hilti vacuum cleaner with suction volume ≥ 61 l/s (VC 20/40 –Y in corded mode only).

**Cleaning alternatives**



<p><b>Compressed Air Cleaning (CAC):</b>                  air nozzle with an orifice opening of minimum 3,5 mm in diameter.</p>	
<p><b>Automatic Cleaning (AC):</b>                  Cleaning is performed during drilling with Hilti TE-CD and TE-YD drilling system including vacuum cleaner.</p>	

**Injection system Hilti HIT-RE 500 V3**

**Intended use.**  
 Cleaning and setting tools

**Annex B9**

**Table B8: Parameters for use of the Hilti roughening tool TE-YRT**

Associated components				Installation	
Diamond coring 		Roughening tool TE-YRT 	Wear gauge RTG... 	Minimum roughening time $t_{\text{roughen}}$	
$d_0$ [mm]		$d_0$ [mm]	size	$t_{\text{roughen}} [\text{sec}] = h_{\text{ef}} [\text{mm}] / 10$	
nominal	measured			$h_{\text{ef}}$ [mm]	$t_{\text{roughen}}$ [sec]
18	17,9 to 18,2	18	18	0 to 100	10
20	19,9 to 20,2	20	20	101 to 200	20
22	21,9 to 22,2	22	22	201 to 300	30
25	24,9 to 25,2	25	25	301 to 400	40
28	27,9 to 28,2	28	28	401 to 500	50
30	29,9 to 30,2	30	30	501 to 600	60
32	31,9 to 32,2	32	32		
35	34,9 to 35,2	35	35		

**Hilti roughening tool TE-YRT and wear gauge RTG**



**Injection system Hilti HIT-RE 500 V3**

**Intended use.**  
 Parameters for use of the Hilti Roughening tool TE-YRT

**Annex B10**

## Installation instruction

### Hole drilling

**a) Hammer drilling:** For dry or wet concrete and installation in water-filled drill holes (no sea water).

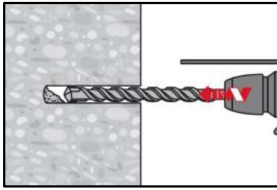

Drill hole to the required embedment depth with a hammer drill set in rotation-hammer mode using an appropriately sized carbide drill bit.

**b) Hammer drilling with Hilti hollow drill bit TE-CD, TE-YD:** For dry and wet concrete only.

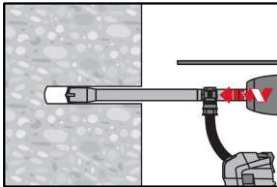

Drill hole to the required embedment depth with an appropriately sized Hilti TE-CD or TE-YD hollow drill bit attached to Hilti vacuum cleaner VC 20/40 (-Y) (suction volume  $\geq 57$  l/s) with automatic cleaning of the filter activated. This drilling system removes the dust and cleans the bore hole during drilling when used in accordance with the user's manual. When using TE-CD 14 refer to Table B7. After drilling is completed, proceed to the "injection preparation" step in the installation instruction.

**c) Diamond coring:** For dry and wet concrete only.

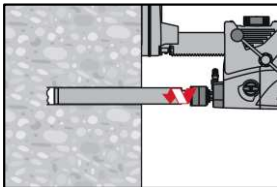

Diamond coring is permissible when suitable diamond core drilling machines and the corresponding core bits are used.

**d) Diamond coring with roughening with Hilti roughening tool TE-YRT:** For dry and wet concrete only.

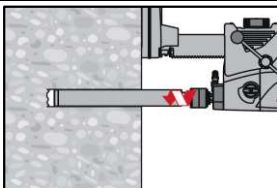

Diamond coring is permissible when suitable diamond core drilling machines and the corresponding core bits are used.

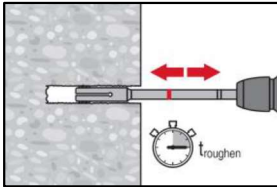

For the use in combination with Hilti roughening tool TE-YRT see parameters in Table B8.

Before roughening free water needs to be removed from the borehole. Check usability of the roughening tool with the wear gauge RTG.

Roughen the borehole over the whole length to the required  $h_{ef}$ .

Injection system Hilti HIT-RE 500 V3

Intended use.  
 Installation instructions

Annex B11

**Drill hole cleaning:** Just before setting an anchor, the drill hole must be free of dust and debris.  
Inadequate hole cleaning = poor load values.

**Compressed Air Cleaning (CAC):** For all drill hole diameters  $d_0$  and all drill hole depths  $h_0$ .

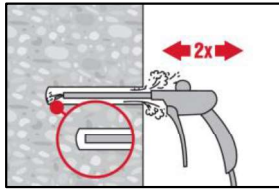

Blow 2 times from the back of the hole (if needed with nozzle extension) over the whole length with oil-free compressed air (min. 6 bar at 6 m<sup>3</sup>/h) until return air stream is free of noticeable dust.

For drill hole diameters  $\geq 32$  mm the compressor has to supply a minimum air flow of 140 m<sup>3</sup>/h.

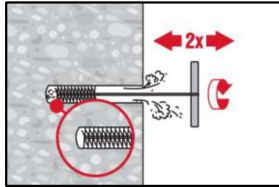

Brush 2 times with the specified brush (see Table B7) by inserting the steel brush Hilti HIT-RB to the back of the hole (if needed with extension) in a twisting motion and removing it.

The brush must produce natural resistance as it enters the drill hole (brush  $\varnothing \geq$  drill hole  $\varnothing$ ) - if not the brush is too small and must be replaced with the proper brush diameter.

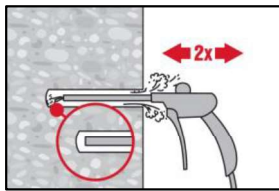

Blow again with compressed air 2 times until return air stream is free of noticeable dust.

Injection system Hilti HIT-RE 500 V3

Intended use.  
Installation instructions

Annex B12

### Cleaning of hammer drilled water-filled drill holes and diamond cored holes:

For all drill hole diameters  $d_0$  and all drill hole depths  $h_0$ .

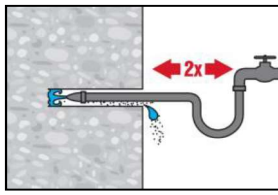

Flush 2 times by inserting a water hose (water-line pressure) to the back of the hole until water runs clear.

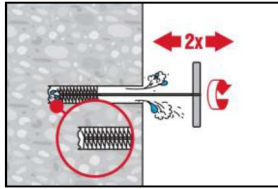

Brush 2 times with the specified brush (see Table B7) by inserting the steel brush Hilti HIT-RB to the back of the hole (if needed with extension) in a twisting motion and removing it.  
The brush must produce natural resistance as it enters the drill hole (brush  $\varnothing \geq$  drill hole  $\varnothing$ ) - if not the brush is too small and must be replaced with the proper brush diameter.

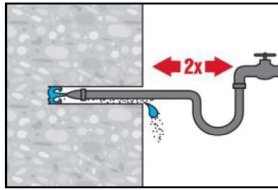

Flush 2 times by inserting a water hose (water-line pressure) to the back of the hole until water runs clear.

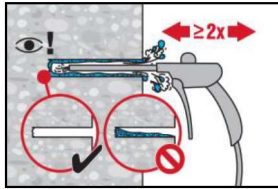

Blow 2 times from the back of the hole (if needed with nozzle extension) over the whole length with oil-free compressed air (min. 6 bar at 6 m<sup>3</sup>/h) until return air stream is free of noticeable dust and water.  
For drill hole diameters  $\geq 32$  mm the compressor has to supply a minimum air flow of 140 m<sup>3</sup>/h.

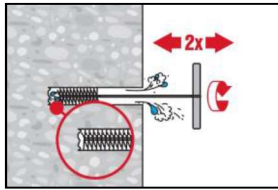

Brush 2 times with the specified brush size (brush  $\varnothing \geq$  drill hole  $\varnothing$ , see Table B7) by inserting the steel brush Hilti HIT-RB to the back of the hole (if needed with extension) in a twisting motion and removing it.  
The brush must produce natural resistance as it enters the drill hole – if not the brush is too small and must be replaced with the proper brush diameter.

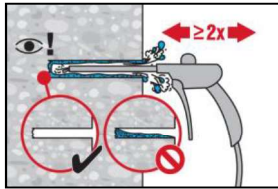

Blow again with compressed air 2 times until return air stream is free of noticeable dust and water.

Injection system Hilti HIT-RE 500 V3

Intended use.  
Installation instructions

Annex B13

### Cleaning of diamond cored holes with roughening with Hilti roughening tool TE-YRT:

For all drill hole diameters  $d_0$  and all drill hole depths  $h_0$ .

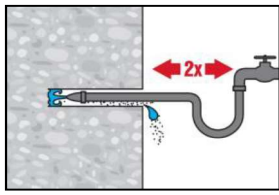

Flush 2 times by inserting a water hose (water-line pressure) to the back of the hole until water runs clear.

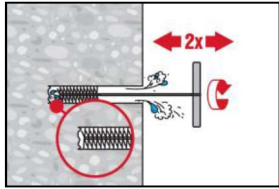

Brush 2 times with the specified brush (see Table B7) by inserting the steel brush Hilti HIT-RB to the back of the hole (if needed with extension) in a twisting motion and removing it.

The brush must produce natural resistance as it enters the drill hole (brush  $\varnothing \geq$  drill hole  $\varnothing$ ) - if not the brush is too small and must be replaced with the proper brush diameter.

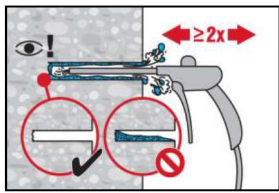

Blow 2 times from the back of the hole (if needed with nozzle extension) over the whole length with oil-free compressed air (min. 6 bar at 6 m<sup>3</sup>/h) until return air stream is free of noticeable dust and water.

For drill hole diameters  $\geq 32$  mm the compressor has to supply a minimum air flow of 140 m<sup>3</sup>/h.

Injection system Hilti HIT-RE 500 V3

Intended use.  
Installation instructions

Annex B14

**Injection preparation**

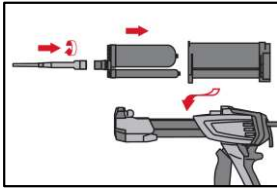

Tightly attach Hilti mixing nozzle HIT-RE-M to foil pack manifold. Do not modify the mixing nozzle.  
 Observe the instruction for use of the dispenser.  
 Check foil pack holder for proper function. Insert foil pack into foil pack holder and put holder into dispenser.

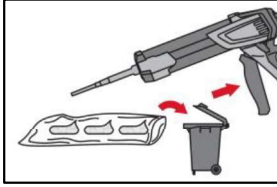

The foil pack opens automatically as dispensing is initiated. Depending on the size of the foil pack an initial amount of adhesive has to be discarded.  
 Discarded quantities are: 3 strokes for 330 ml foil pack,  
 4 strokes for 500 ml foil pack,  
 65 ml for 1400 ml foil pack.

**Inject adhesive from the back of the drill hole without forming air voids.**

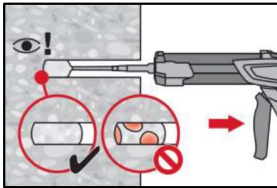

Inject the adhesive starting at the back of the hole, slowly withdrawing the mixer with each trigger pull.  
 Fill approximately 2/3 of the drill hole to ensure that the annular gap between the anchor and the concrete is completely filled with adhesive along the embedment length.

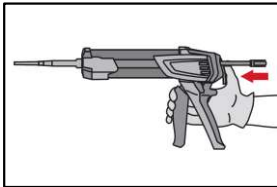

After injection is completed, depressurize the dispenser by pressing the release trigger. This will prevent further adhesive discharge from the mixer.

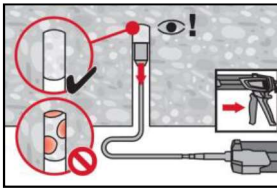

Overhead installation and/or installation with embedment depth  $h_{ef} > 250$  mm. For overhead installation the injection is only possible with the aid of extensions and piston plugs. Assemble HIT-RE-M mixer, extension(s) and appropriately sized piston plug (see Table B7). Insert piston plug to back of the hole and inject adhesive. During injection the piston plug will be naturally extruded out of the drill hole by the adhesive pressure.

**Setting the element**

Just before setting an anchor, the drill hole must be free of dust and debris.

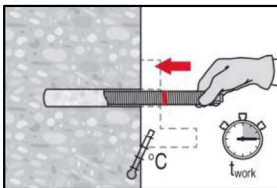

Before use, verify that the element is dry and free of oil and other contaminants. Mark and set element to the required embedment depth before working time  $t_{work}$  has elapsed. The working time  $t_{work}$  is given in Table B6.

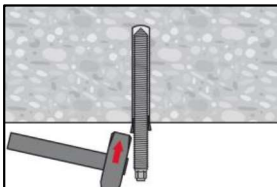

For overhead installation use piston plugs and fix embedded parts with e.g. wedges.

**Injection system Hilti HIT-RE 500 V3**

**Intended use**  
 Installation instructions

**Annex B15**

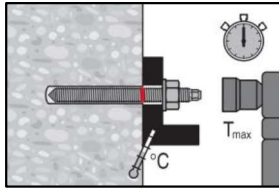

Loading the anchor: After required curing time  $t_{cure}$  (see Table B6) the anchor can be loaded.  
 The applied installation torque shall not exceed the values  $T_{max}$  given in Tables B1, B2, B3 and B4.

**Installation of Filling Set**

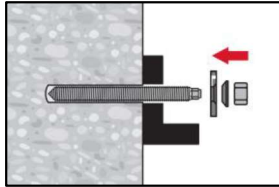

Use Hilti filling set with standard nut. Observe the correct orientation of filling washer and spherical washer.

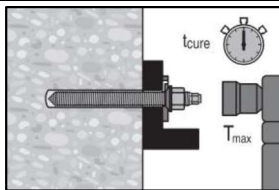

The applied installation torque shall not exceed the values  $T_{max}$  given in Tables B1, B2, B3 and B4.

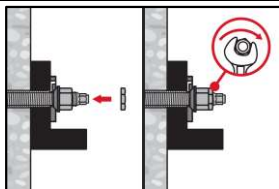

Optional:  
 Installation of lock nut. Tighten with a  $\frac{1}{4}$  to  $\frac{1}{2}$  turn. (Not for size M24.)

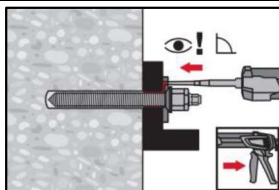

Fill the annular gap between the anchor rod and fixture with 1-3 strokes of a Hilti injection mortar HIT-HY ... or HIT-RE ... .  
 Follow the installation instructions supplied with the Hilti injection mortar.  
 After required curing time  $t_{cure}$  (see Table B6) the anchor can be loaded.

**Injection system Hilti HIT-RE 500 V3**

**Intended use**  
 Installation instructions

**Annex B15**

**Table C1: Essential characteristics for threaded rods under tension load in concrete**

Threaded rod, HAS-U-..., HIT-V-..., AM...8.8			M8	M10	M12	M16	M20	M24	M27	M30	
<b>Steel failure</b>											
Characteristic resistance	$N_{Rk,s}$	[kN]	$A_s \cdot f_{uk}$								
Partial factor Grade 5.8	$\gamma_{Ms,N}^{1)}$	[-]	1,5								
Partial factor Grade 8.8	$\gamma_{Ms,N}^{1)}$	[-]	1,5								
Partial factor HAS-U-R, HIT-V-R	$\gamma_{Ms,N}^{1)}$	[-]	1,87						2,86		
Partial factor HAS-U_HCR, HIT-V-HCR	$\gamma_{Ms,N}^{1)}$	[-]	1,5				2,1				
<b>Installation factor</b>											
Hammer drilling	$\gamma_{inst}$	[-]	1,0								
Hammer drilling with Hilti hollow drill bit TE-CD or TE-YD	$\gamma_{inst}$	[-]	-	1,0							
Diamond coring	$\gamma_{inst}$	[-]	1,2			1,4					
Diamond coring with roughening with Hilti roughening tool TE-YRT	$\gamma_{inst}$	[-]	-			1,0					
Hammer drilling in water-filled drill holes	$\gamma_{inst}$	[-]	1,4								
<b>Concrete cone failure</b>											
Factor for cracked concrete	$k_{cr,N}$	[-]	7,7								
Factor for uncracked concrete	$k_{ucr,N}$	[-]	11,0								
Edge distance	$c_{cr,N}$	[mm]	$1,5 \cdot h_{ef}$								
Spacing	$s_{cr,N}$	[mm]	$3,0 \cdot h_{ef}$								
<b>Splitting failure</b>											
Edge distance $c_{cr,sp}$ [mm] for	$h / h_{ef} \geq 2,0$		$1,0 \cdot h_{ef}$								
	$2,0 > h / h_{ef} > 1,3$		$4,6 \cdot h_{ef} - 1,8 \cdot h$								
	$h / h_{ef} \leq 1,3$		$2,26 \cdot h_{ef}$								
Spacing	$s_{cr,sp}$	[mm]	$2 \cdot c_{cr,sp}$								

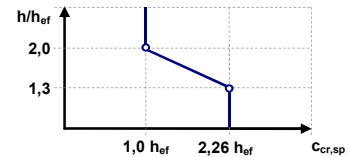

1) In absence of national regulations.

**Injection system Hilti HIT-RE 500 V3**

**Performances**  
 Essential characteristics under tension load in concrete

**Annex C1**

**Table C1: continued**

Threaded rod, HAS-U-..., HIT-V-..., AM...8.8				M8	M10	M12	M16	M20	M24	M27	M30	
<b>Combined pullout and concrete cone failure for a service life of 50 years</b>												
<b>Uncracked concrete C20/25</b> in hammer drilled holes and hammer drilled holes with Hilti hollow drill bit TE-CD or TE-YD and diamond cored holes with roughening with Hilti roughening tool TE-YRT												
Temperature range I:	40°C / 24°C	$\tau_{Rk,ucr}$	[N/mm <sup>2</sup> ]	19	18	18	17	16	15	15	14	
Temperature range II:	70°C / 43°C	$\tau_{Rk,ucr}$	[N/mm <sup>2</sup> ]	14	14	14	13	12	12	11	11	
<b>Uncracked concrete C20/25</b> in diamond cored holes.												
Temperature range I:	40°C / 24°C	$\tau_{Rk,ucr}$	[N/mm <sup>2</sup> ]	13	13	13	13	12	12	12	12	
Temperature range II:	70°C / 43°C	$\tau_{Rk,ucr}$	[N/mm <sup>2</sup> ]	10	9,5	9,5	9,5	9	9	9	9	
<b>Uncracked concrete C20/25</b> in hammer drilled holes and installation in water-filled drill holes												
Temperature range I:	40°C / 24°C	$\tau_{Rk,ucr}$	[N/mm <sup>2</sup> ]	16	16	15	15	14	13	12	12	
Temperature range II:	70°C / 43°C	$\tau_{Rk,ucr}$	[N/mm <sup>2</sup> ]	12	12	12	11	10	10	9,5	9,5	
<b>Cracked concrete C20/25</b> in hammer drilled holes and hammer drilled holes with Hilti hollow drill bit TE-CD or TE-YD and diamond cored holes with roughening with Hilti roughening tool TE-YRT												
Temperature range I:	40°C / 24°C	$\tau_{Rk,cr}$	[N/mm <sup>2</sup> ]	7,5	8	9,5	9,5	9,5	8,5	9	8,5	
Temperature range II:	70°C / 43°C	$\tau_{Rk,cr}$	[N/mm <sup>2</sup> ]	6	7	7,5	7,5	7,5	7	7	6,5	
<b>Influence factors <math>\psi</math> on bond resistance <math>\tau_{Rk}</math></b>												
Influence of concrete strength												
Factor for concrete compressive strength	in hammer drilled holes and hammer drilled holes with Hilti hollow drill bit TE-CD or TE-YD and diamond cored holes	$\psi_c$	C30/37	1,04								
			C40/50	1,07								
			C50/60	1,09								
Factor for concrete compressive strength	in diamond cored holes with roughening with Hilti roughening tool TE-YRT	$\psi_c$	C30/37	-				1,0				
			C40/50									
			C50/60									
Influence of sustained load												
Sustained load factor	in hammer drilled holes and hammer drilled holes with hollow drill bit TE-CD or TE-YD and diamond cored holes with Hilti roughening tool TE-YRT	$\psi_{sus}^0$	40°C / 24°C	0,88								
			70°C / 43°C	0,70								

**Injection system Hilti HIT-RE 500 V3**

**Performances**  
 Essential characteristics under tension load in concrete

**Annex C2**

**Table C1: continued**

Threaded rod, HAS-U-..., HIT-V-..., AM...8.8		M8	M10	M12	M16	M20	M24	M27	M30	
<b>Combined pullout and concrete cone failure for a service life of 100 years</b>										
<b>Uncracked concrete C20/25</b> in hammer drilled holes and hammer drilled holes with Hilti hollow drill bit TE-CD or TE-YD and diamond cored holes with roughening with Hilti roughening tool TE-YRT										
Temperature range I: 40°C / 24°C	$\tau_{Rk,ucr}$	[N/mm <sup>2</sup> ]	19	18	18	17	16	15	15	14
Temperature range II: 70°C / 43°C	$\tau_{Rk,ucr}$	[N/mm <sup>2</sup> ]	14	14	13	13	12	11	11	10
<b>Uncracked concrete C20/25</b> in diamond cored holes.										
Temperature range I: 40°C / 24°C	$\tau_{Rk,ucr}$	[N/mm <sup>2</sup> ]	13	13	13	13	12	12	12	12
Temperature range II: 70°C / 43°C	$\tau_{Rk,ucr}$	[N/mm <sup>2</sup> ]	9,5	9,5	9,5	9	9	9	8,5	8,5
<b>Uncracked concrete C20/25</b> in hammer drilled holes and installation in water-filled drill holes										
Temperature range I: 40°C / 24°C	$\tau_{Rk,ucr}$	[N/mm <sup>2</sup> ]	16	16	15	15	14	13	12	12
Temperature range II: 70°C / 43°C	$\tau_{Rk,ucr}$	[N/mm <sup>2</sup> ]	12	12	11	11	10	9,5	9	9
<b>Cracked concrete C20/25</b> in hammer drilled holes and hammer drilled holes with Hilti hollow drill bit TE-CD or TE-YD and diamond cored holes with roughening with Hilti roughening tool TE-YRT										
Temperature range I: 40°C / 24°C	$\tau_{Rk,cr}$	[N/mm <sup>2</sup> ]	5,5	6,5	7	6,5	6,5	6	6	5,5
Temperature range II: 70°C / 43°C	$\tau_{Rk,cr}$	[N/mm <sup>2</sup> ]	4,5	5	5	5	5	4,5	4,5	4
<b>Influence factors <math>\psi_c</math> on bond resistance <math>\tau_{Rk}</math></b>										
Influence of concrete strength										
Factor for concrete compressive strength	in hammer drilled holes and hammer drilled holes with Hilti hollow drill bit TE-CD or TE-YD and diamond cored holes	$\psi_c$	C30/37	1,04						
			C40/50	1,07						
			C50/60	1,09						
	in diamond cored holes with roughening with Hilti roughening tool TE-YRT	$\psi_c$	C30/37 C40/50 C50/60	-	1,0					

**Injection system Hilti HIT-RE 500 V3**

**Performances**

Essential characteristics under tension load in concrete

**Annex C3**

**Table C2: Essential characteristics for internally threaded sleeve HIS-(R)N under tension load in concrete**

HIS-(R)N			M8	M10	M12	M16	M20
Outer diameter of sleeve	$d_{nom}$	[mm]	12,5	16,5	20,5	25,4	27,6
<b>Steel failure</b>							
HIS-N with screw grade 8.8	$N_{Rk,s}$	[kN]	25	46	67	125	116
Partial factor	$\gamma_{Ms,N}$	[-]	1,5				
HIS-RN with screw grade 70	$N_{Rk,s}$	[kN]	26	41	59	110	166
Partial factor	$\gamma_{Ms,N}$	[-]	1,87				2,4
<b>Installation factor</b>							
Hammer drilling	$\gamma_{inst}$	[-]	1,0				
Hammer drilling with Hilti hollow drill bit TE-CD or TE-YD	$\gamma_{inst}$	[-]	1,0				
Diamond coring	$\gamma_{inst}$	[-]	1,2	1,4			
Diamond coring with roughening with Hilti roughening tool TE-YRT	$\gamma_{inst}$	[-]	-	1,0			
Hammer drilling in water-filled drill holes	$\gamma_{inst}$	[-]	1,4				
<b>Concrete cone failure</b>							
Factor for cracked concrete	$K_{cr,N}$	[-]	7,7				
Factor for uncracked concrete	$K_{ucr,N}$	[-]	11,0				
Edge distance	$c_{cr,N}$	[mm]	$1,5 \cdot h_{ef}$				
Spacing	$s_{cr,N}$	[mm]	$3,0 \cdot h_{ef}$				
<b>Splitting failure</b>							
Edge distance $c_{cr,sp}$ [mm] for	$h / h_{ef} \geq 2,0$		$1,0 \cdot h_{ef}$				
	$2,0 > h / h_{ef} > 1,3$		$4,6 \cdot h_{ef} - 1,8 \cdot h$				
	$h / h_{ef} \leq 1,3$		$2,26 \cdot h_{ef}$				
Spacing	$s_{cr,sp}$	[mm]	$2 \cdot c_{cr,sp}$				

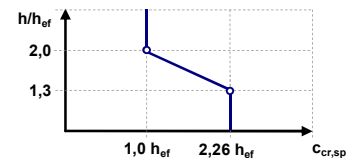

- 1) In absence of national regulations.
- 2) For design according to EN 1992-4:2018, the characteristic tension load values bond resistance may be calculated from the characteristic bond resistance for combined pull-out and concrete cone failure according to:  
 $N_{Rk} = \tau_{Rk} \cdot (h_{ef} \cdot d_{nom} \cdot \pi)$ .

**Injection system Hilti HIT-RE 500 V3**

**Performances**  
 Essential characteristics under tension load in concrete

**Annex C4**

**Table C2: continued**

HIS-(R)N				M8	M10	M12	M16	M20
<b>Combined pullout and concrete cone failure<sup>2)</sup> for a service life of 50 years</b>								
<b>Uncracked concrete C20/25</b> in hammer drilled holes and hammer drilled holes with Hilti hollow drill bit TE-CD or TE-YD and diamond cored holes with roughening with Hilti roughening tool TE-YRT								
Temperature range I:	40°C / 24°C	$\tau_{Rk,ucr}$	[N/mm <sup>2</sup> ]	14	14	14	14	14
Temperature range II:	70°C / 43°C	$\tau_{Rk,ucr}$	[N/mm <sup>2</sup> ]	10	10	10	10	10
<b>Uncracked concrete C20/25</b> in diamond cored holes.								
Temperature range I:	40°C / 24°C	$\tau_{Rk,ucr}$	[N/mm <sup>2</sup> ]	9,0	9,0	9,5	9,5	10
Temperature range II:	70°C / 43°C	$\tau_{Rk,ucr}$	[N/mm <sup>2</sup> ]	6,5	7,0	7,0	7,5	7,5
<b>Uncracked concrete C20/25</b> in hammer drilled holes and installation in water-filled drill holes								
Temperature range I:	40°C / 24°C	$\tau_{Rk,ucr}$	[N/mm <sup>2</sup> ]	12	12	12	12	12
Temperature range II:	70°C / 43°C	$\tau_{Rk,ucr}$	[N/mm <sup>2</sup> ]	9,0	9,0	9,0	9,0	9,0
<b>Cracked concrete C20/25</b> in hammer drilled holes and hammer drilled holes with Hilti hollow drill bit TE-CD or TE-YD and diamond cored holes with roughening with Hilti roughening tool TE-YRT								
Temperature range I:	40°C / 24°C	$\tau_{Rk,cr}$	[N/mm <sup>2</sup> ]	9	9	9	9	9
Temperature range II:	70°C / 43°C	$\tau_{Rk,cr}$	[N/mm <sup>2</sup> ]	7,0	7,0	7,0	7,0	7,0
<b>Influence factors <math>\psi_c</math> on bond resistance <math>\tau_{Rk}</math></b>								
Influence of concrete strength								
Increasing factors for $\tau_{Rk}$ in concrete	in hammer drilled holes and hammer drilled holes with Hilti hollow drill bit TE-CD or TE-YD and diamond cored holes	$\psi_c$	C30/37	1,04				
			C40/50	1,07				
			C50/60	1,09				
In diamond cored holes with roughening with Hilti roughening tool TE-YRT	$\psi_c$	C30/37	-	1,0				
		C40/50						
		C50/60						
Influence of sustained load								
Sustained load factor	in hammer drilled holes and hammer drilled holes with hollow drill bit TE-CD or TE-YD and diamond cored holes with Hilti roughening tool TE-YRT	$\psi_{sus}^0$	40°C / 24°C	0,88				
			70°C / 43°C	0,70				

1) In absence of national regulations.

2) For design according to EN 1992-4:2018, the characteristic tension load values bond resistance may be calculated from the characteristic bond resistance for combined pull-out and concrete cone failure according to:  
 $N_{Rk} = \tau_{Rk} \cdot (h_{ef} \cdot d_{nom} \cdot \pi)$ .

**Injection system Hilti HIT-RE 500 V3**

**Performances**

Essential characteristics under tension load in concrete

**Annex C5**

**Table C2: continued**

HIS-(R)N				M8	M10	M12	M16	M20
<b>Combined pullout and concrete cone failure<sup>2)</sup> for a service life of 100 years</b>								
<b>Uncracked concrete C20/25</b> in hammer drilled holes and hammer drilled holes with Hilti hollow drill bit TE-CD or TE-YD and diamond cored holes with roughening with Hilti roughening tool TE-YRT								
Temperature range I:	40°C / 24°C	$\tau_{Rk,ucr}$	[N/mm <sup>2</sup> ]	14	14	14	14	14
Temperature range II:	70°C / 43°C	$\tau_{Rk,ucr}$	[N/mm <sup>2</sup> ]	10	10	10	10	10
<b>Uncracked concrete C20/25</b> in diamond cored holes.								
Temperature range I:	40°C / 24°C	$\tau_{Rk,ucr}$	[N/mm <sup>2</sup> ]	9	9	9.5	9.5	10
Temperature range II:	70°C / 43°C	$\tau_{Rk,ucr}$	[N/mm <sup>2</sup> ]	6.5	6.5	7	7	7.5
<b>Uncracked concrete C20/25</b> in hammer drilled holes and installation in water-filled drill holes								
Temperature range I:	40°C / 24°C	$\tau_{Rk,ucr}$	[N/mm <sup>2</sup> ]	12	12	12	12	12
Temperature range II:	70°C / 43°C	$\tau_{Rk,ucr}$	[N/mm <sup>2</sup> ]	8,5	8,5	8,5	8,5	8,5
<b>Cracked concrete C20/25</b> in hammer drilled holes and hammer drilled holes with Hilti hollow drill bit TE-CD or TE-YD and diamond cored holes with roughening with Hilti roughening tool TE-YRT								
Temperature range I:	40°C / 24°C	$\tau_{Rk,cr}$	[N/mm <sup>2</sup> ]	5,5	5,5	5,5	6	6
Temperature range II:	70°C / 43°C	$\tau_{Rk,cr}$	[N/mm <sup>2</sup> ]	4,5	4,5	4,5	4,5	4,5
<b>Influence factors <math>\psi</math> on bond resistance <math>\tau_{Rk}</math></b>								
Influence of concrete strength								
Increasing factors for $\tau_{Rk}$ in concrete	in hammer drilled holes and hammer drilled holes with Hilti hollow drill bit TE-CD or TE-YD and diamond cored holes	$\psi_c$	C30/37	1,04				
			C40/50	1,07				
			C50/60	1,09				
	in diamond cored holes with roughening with Hilti roughening tool TE-YRT	$\psi_c$	C30/37 C40/50 C50/60	-	1,0			

1) In absence of national regulations.

2) For design according to EN 1992-4:2018, the characteristic tension load values bond resistance may be calculated from the characteristic bond resistance for combined pull-out and concrete cone failure according to:  
 $N_{Rk} = \tau_{Rk} \cdot (h_{ef} \cdot d_{nom} \cdot \pi)$ .

**Injection system Hilti HIT-RE 500 V3**

**Performances**

Essential characteristics under tension load in concrete

**Annex C6**

**Table C3: Essential characteristics for Hilti tension anchor HZA / HZA-R under tension load in concrete**

HZA / HZA-R			M12	M16	M20	M24	M27
Rebar diameter	$\phi$	[mm]	12	16	20	25	28
<b>Steel failure</b>							
Characteristic resistance HZA	$N_{Rk,s}$	[kN]	46	86	135	194	252
Characteristic resistance HZA-R	$N_{Rk,s}$	[kN]	62	111	173	249	-
Partial factor	$\gamma_{Ms,N}^{1)}$	[-]	1,4				
<b>Installation factor</b>							
Hammer drilling	$\gamma_{inst}$	[-]	1,0				
Hammer drilling with Hilti hollow drill bit TE-CD or TE-YD	$\gamma_{inst}$	[-]	1,0				
Diamond coring	$\gamma_{inst}$	[-]	1,2	1,4			
Diamond coring with roughening with Hilti roughening tool TE-YRT	$\gamma_{inst}$	[-]	-	1,0			
Hammer drilling in water-filled drill holes	$\gamma_{inst}$	[-]	1,4				
<b>Concrete cone failure</b>							
Effective embedment depth	$h_{ef}$	[mm]	$h_{nom}$				
Factor for cracked concrete	$k_{cr,N}$	[-]	7,7				
Factor for uncracked concrete	$k_{ucr,N}$	[-]	11,0				
Edge distance	$c_{cr,N}$	[mm]	$1,5 \cdot h_{ef}$				
Spacing	$s_{cr,N}$	[mm]	$3,0 \cdot h_{ef}$				
<b>Splitting failure</b>							
Edge distance $c_{cr,sp}$ [mm] for	$h / h_{ef} \geq 2,0$		$1,0 \cdot h_{ef}$				
	$2,0 > h / h_{ef} > 1,3$		$4,6 \cdot h_{ef} - 1,8 \cdot h$				
	$h / h_{ef} \leq 1,3$		$2,26 \cdot h_{ef}$				
Spacing	$s_{cr,sp}$	[mm]	$2 \cdot c_{cr,sp}$				

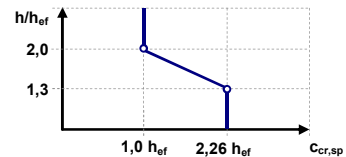

Injection system Hilti HIT-RE 500 V3

**Performances**  
 Essential characteristics under tension load in concrete

**Annex C7**

**Table C3: continued**

HZA / HZA-R				M12	M16	M20	M24	M27
Rebar diameter	$\phi$	[mm]		12	16	20	25	28
<b>Combined pullout and concrete cone failure for a service life of 50 years</b>								
Effective embedment depth	HZA	$h_{ef}$	[mm]	$h_{nom} -20$				
	HZA-R	$h_{ef}$	[mm]	$h_{nom} -100$				-
<b>Uncracked concrete C20/25</b> in hammer drilled holes and hammer drilled holes with Hilti hollow drill bit TE-CD or TE-YD and diamond cored holes with roughening with Hilti roughening tool TE-YRT								
Temperature range I:	40°C / 24°C	$\tau_{Rk,ucr}$	[N/mm <sup>2</sup> ]	15	15	14	13	13
Temperature range II:	70°C / 43°C	$\tau_{Rk,ucr}$	[N/mm <sup>2</sup> ]	11	11	11	10	10
<b>Uncracked concrete C20/25</b> in diamond cored holes.								
Temperature range I:	40°C / 24°C	$\tau_{Rk,ucr}$	[N/mm <sup>2</sup> ]	9	9	9	9	9,5
Temperature range II:	70°C / 43°C	$\tau_{Rk,ucr}$	[N/mm <sup>2</sup> ]	6,5	6,5	7	7	7
<b>Uncracked concrete C20/25</b> in hammer drilled holes and installation in water-filled drill holes								
Temperature range I:	40°C / 24°C	$\tau_{Rk,ucr}$	[N/mm <sup>2</sup> ]	12	12	12	11	11
Temperature range II:	70°C / 43°C	$\tau_{Rk,ucr}$	[N/mm <sup>2</sup> ]	9,5	9,5	9,0	9,0	8,5
<b>Cracked concrete C20/25</b> in hammer drilled holes and hammer drilled holes with Hilti hollow drill bit TE-CD or TE-YD and diamond cored holes with roughening with Hilti roughening tool TE-YRT								
Temperature range I:	40°C / 24°C	$\tau_{Rk,cr}$	[N/mm <sup>2</sup> ]	9,5	10	10	10	11
Temperature range II:	70°C / 43°C	$\tau_{Rk,cr}$	[N/mm <sup>2</sup> ]	7,5	7,5	8	8	8
<b>Influence factors <math>\psi</math> on bond resistance <math>\tau_{Rk}</math></b>								
Influence of concrete strength								
Increasing factors for $\tau_{Rk}$ in concrete	in hammer drilled holes and hammer drilled holes with Hilti hollow drill bit TE-CD or TE-YD and diamond cored holes	$\psi_c$	C30/37	1,04				
			C40/50	1,07				
			C50/60	1,09				
	in diamond cored holes with roughening with Hilti roughening tool TE-YRT	$\psi_c$	C30/37 C40/50 C50/60	1,0				
Influence of sustained load								
Sustained load factor	in hammer drilled holes and hammer drilled holes with hollow drill bit TE-CD or TE-YD and diamond cored holes with Hilti roughening tool TE-YRT	$\psi^{0}_{sus}$	40°C / 24°C	0,88				
			70°C / 43°C	0,70				

**Injection system Hilti HIT-RE 500 V3**

**Performances**

Essential characteristics under tension load in concrete

**Annex C8**

**Table C3: continued**

HZA / HZA-R				M12	M16	M20	M24	M27
Rebar diameter	$\phi$	[mm]		12	16	20	25	28
<b>Combined pullout and concrete cone failure for a service life of 100 years</b>								
Effective embedment depth	HZA	$h_{ef}$	[mm]	$h_{nom} -20$				
	HZA-R	$h_{ef}$	[mm]	$h_{nom} -100$				-
<b>Uncracked concrete C20/25</b> in hammer drilled holes and hammer drilled holes with Hilti hollow drill bit TE-CD or TE-YD and diamond cored holes with roughening with Hilti roughening tool TE-YRT								
Temperature range I:	40°C / 24°C	$\tau_{Rk,ucr}$	[N/mm <sup>2</sup> ]	15	15	14	14	14
Temperature range II:	70°C / 43°C	$\tau_{Rk,ucr}$	[N/mm <sup>2</sup> ]	11	11	10	10	10
<b>Uncracked concrete C20/25</b> in diamond cored holes.								
Temperature range I:	40°C / 24°C	$\tau_{Rk,ucr}$	[N/mm <sup>2</sup> ]	10	11	11	11	11
Temperature range II:	70°C / 43°C	$\tau_{Rk,ucr}$	[N/mm <sup>2</sup> ]	7,5	8	8	8	8
<b>Uncracked concrete C20/25</b> in hammer drilled holes and installation in water-filled drilled holes								
Temperature range I:	40°C / 24°C	$\tau_{Rk,ucr}$	[N/mm <sup>2</sup> ]	12	12	12	11	11
Temperature range II:	70°C / 43°C	$\tau_{Rk,ucr}$	[N/mm <sup>2</sup> ]	9,5	9	9	9	8,5
<b>Cracked concrete C20/25</b> in hammer drilled holes and hammer drilled holes with Hilti hollow drill bit TE-CD or TE-YD and diamond cored holes with roughening with Hilti roughening tool TE-YRT								
Temperature range I:	40°C / 24°C	$\tau_{Rk,cr}$	[N/mm <sup>2</sup> ]	8	8	7,5	7,5	7,5
Temperature range II:	70°C / 43°C	$\tau_{Rk,cr}$	[N/mm <sup>2</sup> ]	6	5,5	5,5	5,5	5,5
<b>Influence factors <math>\psi</math> on bond resistance <math>\tau_{Rk}</math></b>								
Influence of concrete strength								
Increasing factors for $\tau_{Rk}$ in concrete	in hammer drilled holes and hammer drilled holes with Hilti hollow drill bit TE-CD or TE-YD and diamond cored holes	$\psi_c$	C30/37	1,04				
			C40/50	1,07				
			C50/60	1,09				
	in diamond cored holes with roughening with Hilti roughening tool TE-YRT	$\psi_c$	C30/37 C40/50 C50/60	1,0				

**Injection system Hilti HIT-RE 500 V3**

**Performances**

Essential characteristics under tension load in concrete

**Annex C9**

**Table C4: Essential characteristics for reinforcing bars (rebars) under tension load in concrete**

Reinforcing bar (rebar)	$\phi 8$	$\phi 10$	$\phi 12$	$\phi 14$	$\phi 16$	$\phi 20$	$\phi 25$	$\phi 28$	$\phi 30$	$\phi 32$	
<b>Steel failure</b>											
Rebar B500B acc. to DIN 488:2009-08 <sup>2)</sup> $N_{Rk,s}$ [kN]	28	43	62	85	111	173	270	339	388	442	
Partial factor <sup>3)</sup> $\gamma_{Ms,N}$ <sup>1)</sup> [-]	1,4										
<b>Installation factor</b>											
Hammer drilling $\gamma_{inst}$ [-]	1,0										
Hammer drilling with Hilti hollow drill bit TE-CD or TE-YD $\gamma_{inst}$ [-]	-	1,0							-		
Diamond coring $\gamma_{inst}$ [-]	1,2					1,4					
Diamond coring with roughening with Hilti roughening tool TE-YRT $\gamma_{inst}$ [-]	-	1,0							-		
Hammer drilling in water-filled drill holes $\gamma_{inst}$ [-]	1,4										
<b>Concrete cone failure</b>											
Factor for cracked concrete $k_{cr,N}$ [-]	7,7										
Factor for uncracked concrete $k_{ucr,N}$ [-]	11,0										
Edge distance $c_{cr,N}$ [mm]	$1,5 \cdot h_{ef}$										
Spacing $s_{cr,N}$ [mm]	$3,0 \cdot h_{ef}$										
<b>Splitting failure</b>											
Edge distance $c_{cr,sp}$ [mm] for	$h / h_{ef} \geq 2,0$	$1,0 \cdot h_{ef}$									
	$2,0 > h / h_{ef} > 1,3$	$4,6 \cdot h_{ef} - 1,8 \cdot h$									
	$h / h_{ef} \leq 1,3$	$2,26 \cdot h_{ef}$									
Spacing $s_{cr,sp}$ [mm]	$2 \cdot c_{cr,sp}$										

1) In absence of national regulations.

2) Values need to be calculated acc. EAD 330499-01, Eq. 2.1, if rebars do not fulfil the requirements acc. DIN 488.

3) Values need to be calculated acc. EN 1992-4:2018, tab 4.1, if rebars do not fulfil the requirements acc. DIN 488.

**Injection system Hilti HIT-RE 500 V3**

**Performances**

Essential characteristics under tension load in concrete

**Annex C10**

**Table C4: continued**

Reinforcing bar (rebar)				φ 8	φ 10	φ 12	φ 14	φ 16	φ 20	φ 25	φ 28	φ 30	φ 32
<b>Combined pullout and concrete cone failure for a service life of 50 years</b>													
<b>Uncracked concrete C20/25</b> in hammer drilled holes and hammer drilled holes with Hilti hollow drill bit TE-CD or TE-YD and diamond cored holes with roughening with Hilti roughening tool TE-YRT													
Temperature range I:	40°C / 24°C	$\tau_{Rk,ucr}$	[N/mm <sup>2</sup> ]	10	15	15	15	15	14	13	13	13	13
Temperature range II:	70°C / 43°C	$\tau_{Rk,ucr}$	[N/mm <sup>2</sup> ]	7,5	11	11	11	11	11	10	10	10	10
<b>Uncracked concrete C20/25</b> in diamond cored holes.													
Temperature range I:	40°C / 24°C	$\tau_{Rk,ucr}$	[N/mm <sup>2</sup> ]	9	9	9	9	9	9	9	9,5	9,5	9,5
Temperature range II:	70°C / 43°C	$\tau_{Rk,ucr}$	[N/mm <sup>2</sup> ]	6,5	6,5	6,5	6,5	6,5	7	7	7	7	7
<b>Uncracked concrete C20/25</b> in hammer drilled holes and installation in water-filled drill holes													
Temperature range I:	40°C / 24°C	$\tau_{Rk,ucr}$	[N/mm <sup>2</sup> ]	8	12	12	12	12	12	11	11	11	11
Temperature range II:	70°C / 43°C	$\tau_{Rk,ucr}$	[N/mm <sup>2</sup> ]	6,5	9,5	9,5	9,5	9,5	9	9	8,5	8,5	8,5
<b>Cracked concrete C20/25</b> in hammer drilled holes and hammer drilled holes with Hilti hollow drill bit TE-CD or TE-YD and diamond cored holes with roughening with Hilti roughening tool TE-YRT													
Temperature range I:	40°C / 24°C	$\tau_{Rk,cr}$	[N/mm <sup>2</sup> ]	5	8,5	9,5	9,5	10	10	10	11	11	11
Temperature range II:	70°C / 43°C	$\tau_{Rk,cr}$	[N/mm <sup>2</sup> ]	4	7	7,5	7,5	7,5	8	8	8	8,5	8,5
<b>Influence factors <math>\psi_c</math> on bond resistance <math>\tau_{Rk}</math></b>													
Influence of concrete strength													
Factor for concrete compressive strength	in hammer drilled holes and hammer drilled holes with Hilti hollow drill bit TE-CD or TE-YD and diamond cored holes	$\psi_c$	C30/37	1,04									
			C40/50	1,07									
			C50/60	1,09									
Factor for concrete compressive strength	in diamond cored holes with roughening with Hilti roughening tool TE-YRT	$\psi_c$	C30/37	1,0									
			C40/50										
			C50/60										
Influence of sustained load													
Sustained load factor	in hammer drilled holes and hammer drilled holes with hollow drill bit TE-CD or TE-YD and diamond cored holes with Hilti roughening tool TE-YRT	$\psi^{0sus}$	40°C / 24°C	0,88									
			70°C / 43°C	0,70									

1) In absence of national regulations.

2) Values need to be calculated acc. EAD 330499-01, Eq. 2.1, if rebars do not fulfil the requirements acc. DIN 488.

3) Values need to be calculated acc. EN 1992-4:2018, tab 4.1, if rebars do not fulfil the requirements acc. DIN 488.

**Injection system Hilti HIT-RE 500 V3**

**Performances**

Essential characteristics under tension load in concrete

**Annex C11**

Table C4: continued

Reinforcing bar (rebar)				φ 8	φ 10	φ 12	φ 14	φ 16	φ 20	φ 25	φ 28	φ 30	φ 32
<b>Combined pullout and concrete cone failure for a service life of 100 years</b>													
<b>Uncracked concrete C20/25</b> in hammer drilled holes and hammer drilled holes with Hilti hollow drill bit TE-CD or TE-YD and diamond cored holes with roughening with Hilti roughening tool TE-YRT													
Temperature range I:	40°C / 24°C	$\tau_{Rk,ucr}$	[N/mm <sup>2</sup> ]	10	15	15	15	15	14	13	13	13	13
Temperature range II:	70°C / 43°C	$\tau_{Rk,ucr}$	[N/mm <sup>2</sup> ]	7	11	11	11	11	10	10	10	10	10
<b>Uncracked concrete C20/25</b> in diamond cored holes.													
Temperature range I:	40°C / 24°C	$\tau_{Rk,ucr}$	[N/mm <sup>2</sup> ]	9	9	9	9	9	9	9	9,5	9,5	9,5
Temperature range II:	70°C / 43°C	$\tau_{Rk,ucr}$	[N/mm <sup>2</sup> ]	6,5	6,5	6,5	6,5	6,5	7	7	7	7	7
<b>Uncracked concrete C20/25</b> in hammer drilled holes and installation in water-filled drill holes													
Temperature range I:	40°C / 24°C	$\tau_{Rk,ucr}$	[N/mm <sup>2</sup> ]	8	12	12	12	12	12	11	11	11	11
Temperature range II:	70°C / 43°C	$\tau_{Rk,ucr}$	[N/mm <sup>2</sup> ]	6	9,5	9,5	9,5	9	9	9	8,5	8,5	8,5
<b>Cracked concrete C20/25</b> in hammer drilled holes and hammer drilled holes with Hilti hollow drill bit TE-CD or TE-YD and diamond cored holes with roughening with Hilti roughening tool TE-YRT													
Temperature range I:	40°C / 24°C	$\tau_{Rk,cr}$	[N/mm <sup>2</sup> ]	5	7,5	8	8	8	7,5	7,5	7,5	7	7
Temperature range II:	70°C / 43°C	$\tau_{Rk,cr}$	[N/mm <sup>2</sup> ]	4	5,5	6	6	5,5	5,5	5,5	5,5	5	5
<b>Influence factors <math>\psi</math> on bond resistance <math>\tau_{Rk}</math></b>													
Influence of concrete strength													
Factor for concrete compressive strength	in hammer drilled holes and hammer drilled holes with Hilti hollow drill bit TE-CD or TE-YD and diamond cored holes	$\psi_c$	C30/37	1,04									
			C40/50	1,07									
			C50/60	1,09									
	in diamond cored holes with roughening with Hilti roughening tool TE-YRT	$\psi_c$	C30/37	1,0									
			C40/50										
			C50/60										

1) In absence of national regulations.

2) Values need to be calculated acc. EAD 330499-01, Eq. 2.1, if rebars do not fulfil the requirements acc. DIN 488.

3) Values need to be calculated acc. EN 1992-4:2018, tab 4.1, if rebars do not fulfil the requirements acc. DIN 488.

Injection system Hilti HIT-RE 500 V3

**Performances**

Essential characteristics under tension load in concrete

Annex C12

**Table C5: Essential characteristics for threaded rods under shear load in concrete**

Threaded rod, HAS-U-..., HIT-V-..., AM...8.8			M8	M10	M12	M16	M20	M24	M27	M30	
<b>Steel failure without lever arm</b>											
Threaded rod, HAS-U-..., HIT-V-..., AM...8.8	$V_{Rk,s}$	[kN]	0,5 · $A_s$ · $f_{uk}$								
Partial factor grade 5.8	$\gamma_{Ms,v}$ <sup>1)</sup>	[-]	1,25								
Partial factor grade 8.8	$\gamma_{Ms,v}$ <sup>1)</sup>	[-]	1,25								
Partial factor HAS-U-R, HIT-V-R	$\gamma_{Ms,v}$ <sup>1)</sup>	[-]	1,56						2,38		
Partial factor HAS-U-HCR, HIT-V-HCR	$\gamma_{Ms,v}$ <sup>1)</sup>	[-]	1,25				1,75				
Ductility factor	$k_7$	[-]	1,0								
<b>Steel failure with lever arm</b>											
Bending moment	$M^0_{Rk,s}$	[Nm]	1,2 · $W_{el}$ · $f_{uk}$								
Ductility factor	$k_7$	[-]	1,0								
<b>Concrete pry-out failure</b>											
Pry-out factor	$k_8$	[-]	2,0								
<b>Concrete edge failure</b>											
Effective length of fastener	$l_f$	[mm]	min ( $h_{ef}$ ; 12 · $d_{nom}$ ; 300)								
Outside diameter of the anchor	$d_{nom}$	[mm]	8	10	12	16	20	24	27	30	

<sup>1)</sup> In absence of national regulations.

**Injection system Hilti HIT-RE 500 V3**

**Performances**  
 Essential characteristics under shear load in concrete

**Annex C13**

**Table C6: Essential characteristics for internally threaded sleeve HIS-(R)N under shear load in concrete**

HIS-(R)N			M8	M10	M12	M16	M20
<b>Steel failure without lever arm</b>							
HIS-N with screw class 8.8	$V_{Rk,s}$	[kN]	13	23	34	63	58
Partial factor	$\gamma_{Ms,v}^{1)}$	[-]	1,25				
HIS-RN with screw class 70	$V_{Rk,s}$	[kN]	13	20	30	55	83
Partial factor	$\gamma_{Ms,v}^{1)}$	[-]	1,56				
Ductility factor	$k_7$	[-]	1,0				
<b>Steel failure with lever arm</b>							
HIS-N with screw class 8.8	$M^0_{Rk,s}$	[Nm]	30	60	105	266	519
Partial factor	$\gamma_{Ms,v}^{1)}$	[-]	1,25				
HIS-RN with screw class 70	$M^0_{Rk,s}$	[Nm]	26	52	92	233	454
Partial factor	$\gamma_{Ms,v}^{1)}$	[-]	1,56				
Ductility factor	$k_7$	[-]	1,0				
<b>Concrete pry-out failure</b>							
Pry-out factor	$k_8$	[-]	2,0				
<b>Concrete edge failure</b>							
Effective length of fastener	$l_f$	[mm]	90	110	125	170	205
Outside diameter of the anchor	$d_{nom}$	[mm]	12,5	16,5	20,5	25,4	27,6

1) In absence of national regulations.

**Injection system Hilti HIT-RE 500 V3**

**Performances**  
 Essential characteristics under shear load in concrete

**Annex C14**

**Table C7: Essential characteristics for Hilti tension anchor HZA / HZA-R under shear load in concrete**

HZA / HZA-R			M12	M16	M20	M24	M27
Rebar diameter	$\phi$	[mm]	12	16	20	25	28
<b>Steel failure without lever arm</b>							
HZA	$V_{Rk,s}$	[kN]	23	43	67	97	126
HZA-R	$V_{Rk,s}$	[kN]	31	55	86	124	-
Partial factor	$\gamma_{Ms,v}^{1)}$	[-]	1,5				
Ductility factor	$k_7$	[-]	1,0				
<b>Steel failure with lever arm</b>							
HZA	$M^0_{Rk,s}$	[Nm]	72	183	357	617	915
HZA-R	$M^0_{Rk,s}$	[Nm]	97	234	458	790	-
Partial factor	$\gamma_{Ms,v}^{1)}$	[-]	1,5				
Ductility factor	$k_7$	[-]	1,0				
<b>Concrete pryout failure</b>							
Pry-out factor	$k_8$	[-]	2.0				
<b>Concrete edge failure</b>							
Effective length of fastener	$l_f$	[mm]	min ( $h_{ef}$ ; $12 \cdot d_{nom}$ ; 300)				
Outside diameter of the anchor	$d_{nom}$	[mm]	12	16	20	24	27

<sup>1)</sup> In absence of national regulations.

Injection system Hilti HIT-RE 500 V3

**Performances**

Essential characteristics under shear load in concrete

**Annex C15**

**Table C8: Essential characteristics for reinforcing bars (rebars) under shear load in concrete**

Reinforcing bar (rebar)		φ 8	φ 10	φ 12	φ 14	φ 16	φ 20	φ 25	φ 28	φ 30	φ 32	
<b>Steel failure without lever arm</b>												
Rebar B500B acc. to DIN 488:2009-08 <sup>2)</sup>	$V_{Rk,s}$	[kN]	14	22	31	42	55	86	135	169	194	221
Partial factor <sup>3)</sup>	$\gamma_{Ms,v}$ <sup>1)</sup>	[-]	1,5									
Ductility factor	$k_7$	[-]	1,0									
<b>Steel failure with lever arm</b>												
Rebar B500B acc. to DIN 488:2009-08 <sup>2)</sup>	$M^0_{Rk,s}$	[Nm]	33	65	112	178	265	518	1012	1422	1749	2123
Partial factor <sup>3)</sup>	$\gamma_{Ms,v}$ <sup>1)</sup>	[-]	1,5									
Ductility factor	$k_7$	[-]	1,0									
<b>Concrete pry-out failure</b>												
Pry-out factor	$k_8$	[-]	2,0									
<b>Concrete edge failure</b>												
Effective length of fastener	$l_f$	[mm]	min ( $h_{ef}$ ; $12 \cdot d_{nom}$ ; 300)									
Outside diameter of the anchor	$d_{nom}$	[mm]	8	10	12	14	16	20	25	28	30	32

1) In absence of national regulations.

2) Values need to be calculated acc. EAD 330499-01, Eq. 2.1, if rebars do not fulfil the requirements acc. DIN 488.

3) Values need to be calculated acc. EN 1992-4:2018, tab 4.1, if rebars do not fulfil the requirements acc. DIN 488.

**Injection system Hilti HIT-RE 500 V3**

**Performances**

Essential characteristics under shear load in concrete

**Annex C16**

**Table C9: Displacements under tension load**

Threaded rod, HAS-U-..., HIT-V-..., AM...8.8			M8	M10	M12	M16	M20	M24	M27	M30
<b>for a service life of 50 years</b>										
Uncracked concrete temperature range I: 40°C / 24°C										
Displacement	$\delta_{N0}$	[mm/(N/mm <sup>2</sup> )]	0,04	0,05	0,05	0,06	0,06	0,07	0,08	0,08
	$\delta_{N\infty}$	[mm/(N/mm <sup>2</sup> )]	0,10	0,11	0,12	0,13	0,15	0,17	0,18	0,19
Uncracked concrete temperature range II: 70°C / 43°C										
Displacement	$\delta_{N0}$	[mm/(N/mm <sup>2</sup> )]	0,05	0,05	0,06	0,07	0,07	0,08	0,09	0,10
	$\delta_{N\infty}$	[mm/(N/mm <sup>2</sup> )]	0,12	0,13	0,14	0,16	0,18	0,20	0,21	0,23
Cracked concrete temperature range I: 40°C / 24°C										
Displacement	$\delta_{N0}$	[mm/(N/mm <sup>2</sup> )]	0,02	0,03	0,05	0,08	0,10	0,13	0,15	0,18
	$\delta_{N\infty}$	[mm/(N/mm <sup>2</sup> )]	0,12	0,19	0,14	0,19	0,16	0,16	0,15	0,18
Cracked concrete temperature range II: 70°C / 43°C										
Displacement	$\delta_{N0}$	[mm/(N/mm <sup>2</sup> )]	0,02	0,04	0,06	0,09	0,12	0,16	0,18	0,21
	$\delta_{N\infty}$	[mm/(N/mm <sup>2</sup> )]	0,15	0,23	0,17	0,23	0,19	0,19	0,18	0,21
<b>for a service life of 100 years</b>										
Uncracked concrete temperature range I: 40°C / 24°C										
Displacement	$\delta_{N0}$	[mm/(N/mm <sup>2</sup> )]	0,04	0,05	0,05	0,06	0,06	0,07	0,08	0,08
	$\delta_{N\infty}$	[mm/(N/mm <sup>2</sup> )]	0,12	0,13	0,14	0,16	0,18	0,20	0,22	0,23
Uncracked concrete temperature range II: 70°C / 43°C										
Displacement	$\delta_{N0}$	[mm/(N/mm <sup>2</sup> )]	0,05	0,05	0,06	0,07	0,07	0,08	0,09	0,10
	$\delta_{N\infty}$	[mm/(N/mm <sup>2</sup> )]	0,12	0,13	0,14	0,16	0,19	0,21	0,22	0,24
Cracked concrete temperature range I: 40°C / 24°C										
Displacement	$\delta_{N0}$	[mm/(N/mm <sup>2</sup> )]	0,02	0,03	0,05	0,08	0,10	0,13	0,15	0,18
	$\delta_{N\infty}$	[mm/(N/mm <sup>2</sup> )]	0,13	0,20	0,16	0,22	0,19	0,21	0,22	0,24
Cracked concrete temperature range II: 70°C / 43°C										
Displacement	$\delta_{N0}$	[mm/(N/mm <sup>2</sup> )]	0,02	0,04	0,06	0,09	0,12	0,16	0,18	0,21
	$\delta_{N\infty}$	[mm/(N/mm <sup>2</sup> )]	0,15	0,24	0,19	0,26	0,23	0,24	0,24	0,28

**Table C10: Displacements under shear load**

Threaded rod, HAS-U-..., HIT-V-..., AM...8.8			M8	M10	M12	M16	M20	M24	M27	M30
Displacement	$\delta_{V0}$	[mm/kN]	0,06	0,06	0,05	0,04	0,04	0,03	0,03	0,03
	$\delta_{V\infty}$	[mm/kN]	0,09	0,08	0,08	0,06	0,06	0,05	0,05	0,05

Injection system Hilti HIT-RE 500 V3

Performances  
Displacements

Annex C17

**Table C11: Displacements under tension load**

HIS-(R)N		M8	M10	M12	M16	M20	
<b>for a service life of 50 years</b>							
Uncracked concrete temperature range I: 40°C / 24°C							
Displacement	$\delta_{N0}$	[mm/(N/mm <sup>2</sup> )]	0,05	0,06	0,06	0,07	0,08
	$\delta_{N\infty}$	[mm/(N/mm <sup>2</sup> )]	0,12	0,13	0,15	0,17	0,18
Uncracked concrete temperature range II: 70°C / 43°C							
Displacement	$\delta_{N0}$	[mm/(N/mm <sup>2</sup> )]	0,06	0,07	0,07	0,08	0,09
	$\delta_{N\infty}$	[mm/(N/mm <sup>2</sup> )]	0,14	0,16	0,18	0,20	0,21
Cracked concrete temperature range I: 40°C / 24°C							
Displacement	$\delta_{N0}$	[mm/(N/mm <sup>2</sup> )]	0,05	0,08	0,10	0,13	0,15
	$\delta_{N\infty}$	[mm/(N/mm <sup>2</sup> )]	0,14	0,19	0,16	0,16	0,15
Cracked concrete temperature range II: 70°C / 43°C							
Displacement	$\delta_{N0}$	[mm/(N/mm <sup>2</sup> )]	0,06	0,09	0,12	0,16	0,18
	$\delta_{N\infty}$	[mm/(N/mm <sup>2</sup> )]	0,17	0,23	0,19	0,19	0,18
<b>for a service life of 100 years</b>							
Uncracked concrete temperature range I: 40°C / 24°C							
Displacement	$\delta_{N0}$	[mm/(N/mm <sup>2</sup> )]	0,05	0,06	0,06	0,07	0,08
	$\delta_{N\infty}$	[mm/(N/mm <sup>2</sup> )]	0,14	0,15	0,18	0,20	0,21
Uncracked concrete temperature range II: 70°C / 43°C							
Displacement	$\delta_{N0}$	[mm/(N/mm <sup>2</sup> )]	0,06	0,07	0,07	0,08	0,09
	$\delta_{N\infty}$	[mm/(N/mm <sup>2</sup> )]	0,15	0,17	0,19	0,21	0,22
Cracked concrete temperature range I: 40°C / 24°C							
Displacement	$\delta_{N0}$	[mm/(N/mm <sup>2</sup> )]	0,05	0,08	0,10	0,13	0,15
	$\delta_{N\infty}$	[mm/(N/mm <sup>2</sup> )]	0,15	0,22	0,19	0,20	0,20
Cracked concrete temperature range II: 70°C / 43°C							
Displacement	$\delta_{N0}$	[mm/(N/mm <sup>2</sup> )]	0,06	0,09	0,12	0,16	0,18
	$\delta_{N\infty}$	[mm/(N/mm <sup>2</sup> )]	0,19	0,27	0,23	0,24	0,24

**Table C12: Displacements under shear load**

HIS-(R)N		M8	M10	M12	M16	M20	
Displacement	$\delta_{V0}$	[mm/kN]	0,06	0,06	0,05	0,04	0,04
	$\delta_{V\infty}$	[mm/kN]	0,09	0,08	0,08	0,06	0,06

**Injection system Hilti HIT-RE 500 V3**

**Performances**  
Displacements

**Annex C18**

**Table C13: Displacements under tension load**

HZA / HZA-R		M12	M16	M20	M24	M27	
<b>for a service life of 50 years</b>							
Uncracked concrete temperature range I: 40°C / 24°C							
Displacement	$\delta_{N0}$	[mm/(N/mm <sup>2</sup> )]	0,05	0,06	0,06	0,07	0,08
	$\delta_{N\infty}$	[mm/(N/mm <sup>2</sup> )]	0,12	0,13	0,15	0,17	0,18
Uncracked concrete temperature range II: 70°C / 43°C							
Displacement	$\delta_{N0}$	[mm/(N/mm <sup>2</sup> )]	0,06	0,07	0,07	0,08	0,09
	$\delta_{N\infty}$	[mm/(N/mm <sup>2</sup> )]	0,14	0,16	0,18	0,20	0,21
Cracked concrete temperature range I: 40°C / 24°C							
Displacement	$\delta_{N0}$	[mm/(N/mm <sup>2</sup> )]	0,05	0,08	0,10	0,13	0,15
	$\delta_{N\infty}$	[mm/(N/mm <sup>2</sup> )]	0,14	0,19	0,16	0,16	0,15
Cracked concrete temperature range II: 70°C / 43°C							
Displacement	$\delta_{N0}$	[mm/(N/mm <sup>2</sup> )]	0,06	0,09	0,12	0,16	0,18
	$\delta_{N\infty}$	[mm/(N/mm <sup>2</sup> )]	0,17	0,23	0,19	0,19	0,18
<b>for a service life of 100 years</b>							
Uncracked concrete temperature range I: 40°C / 24°C							
Displacement	$\delta_{N0}$	[mm/(N/mm <sup>2</sup> )]	0,05	0,06	0,06	0,07	0,08
	$\delta_{N\infty}$	[mm/(N/mm <sup>2</sup> )]	0,14	0,15	0,18	0,20	0,21
Uncracked concrete temperature range II: 70°C / 43°C							
Displacement	$\delta_{N0}$	[mm/(N/mm <sup>2</sup> )]	0,06	0,07	0,07	0,08	0,09
	$\delta_{N\infty}$	[mm/(N/mm <sup>2</sup> )]	0,15	0,17	0,19	0,21	0,22
Cracked concrete temperature range I: 40°C / 24°C							
Displacement	$\delta_{N0}$	[mm/(N/mm <sup>2</sup> )]	0,05	0,08	0,10	0,13	0,15
	$\delta_{N\infty}$	[mm/(N/mm <sup>2</sup> )]	0,15	0,22	0,19	0,20	0,20
Cracked concrete temperature range II: 70°C / 43°C							
Displacement	$\delta_{N0}$	[mm/(N/mm <sup>2</sup> )]	0,06	0,09	0,12	0,16	0,18
	$\delta_{N\infty}$	[mm/(N/mm <sup>2</sup> )]	0,19	0,26	0,23	0,24	0,23

**Table C14: Displacements under shear load**

HZA / HZA-R		M12	M16	M20	M24	M27	
Displacement	$\delta_{v0}$	[mm/kN]	0,05	0,04	0,04	0,03	0,03
	$\delta_{v\infty}$	[mm/kN]	0,08	0,06	0,06	0,05	0,05

**Injection system Hilti HIT-RE 500 V3**

**Performances**  
Displacements

**Annex C19**

**Table C15: Displacements under tension load**

Reinforcing bar (rebar)		φ 8	φ 10	φ 12	φ 14	φ 16	φ 20	φ 25	φ 28	φ 30	φ 32	
<b>for a service life of 50 years</b>												
Uncracked concrete temperature range I: 40°C / 24°C												
Displacement	$\delta_{N0}$	[mm/(N/mm <sup>2</sup> )]	0,05	0,05	0,05	0,06	0,06	0,07	0,07	0,08	0,08	0,08
	$\delta_{N\infty}$	[mm/(N/mm <sup>2</sup> )]	0,11	0,11	0,00	0,13	0,15	0,17	0,18	0,19	0,19	0,20
Uncracked concrete temperature range II: 70°C / 43°C												
Displacement	$\delta_{N0}$	[mm/(N/mm <sup>2</sup> )]	0,05	0,05	0,06	0,07	0,07	0,09	0,09	0,09	0,10	0,10
	$\delta_{N\infty}$	[mm/(N/mm <sup>2</sup> )]	0,13	0,13	0,00	0,16	0,18	0,20	0,21	0,22	0,23	0,24
Cracked concrete temperature range I: 40°C / 24°C												
Displacement	$\delta_{N0}$	[mm/(N/mm <sup>2</sup> )]	0,03	0,03	0,06	0,08	0,10	0,14	0,15	0,16	0,18	0,19
	$\delta_{N\infty}$	[mm/(N/mm <sup>2</sup> )]	0,19	0,19	0,06	0,19	0,16	0,16	0,15	0,16	0,18	0,19
Cracked concrete temperature range II: 70°C / 43°C												
Displacement	$\delta_{N0}$	[mm/(N/mm <sup>2</sup> )]	0,04	0,04	0,07	0,09	0,12	0,17	0,17	0,19	0,21	0,22
	$\delta_{N\infty}$	[mm/(N/mm <sup>2</sup> )]	0,23	0,23	0,07	0,23	0,19	0,19	0,18	0,19	0,21	0,22
<b>for a service life of 100 years</b>												
Uncracked concrete temperature range I: 40°C / 24°C												
Displacement	$\delta_{N0}$	[mm/(N/mm <sup>2</sup> )]	0,05	0,05	0,05	0,06	0,06	0,07	0,07	0,08	0,08	0,08
	$\delta_{N\infty}$	[mm/(N/mm <sup>2</sup> )]	0,12	0,13	0,14	0,16	0,18	0,21	0,21	0,22	0,23	0,24
Uncracked concrete temperature range II: 70°C / 43°C												
Displacement	$\delta_{N0}$	[mm/(N/mm <sup>2</sup> )]	0,05	0,05	0,06	0,07	0,07	0,09	0,09	0,09	0,10	0,10
	$\delta_{N\infty}$	[mm/(N/mm <sup>2</sup> )]	0,12	0,13	0,14	0,16	0,19	0,21	0,22	0,23	0,24	0,25
Cracked concrete temperature range I: 40°C / 24°C												
Displacement	$\delta_{N0}$	[mm/(N/mm <sup>2</sup> )]	0,03	0,03	0,06	0,08	0,10	0,14	0,15	0,16	0,18	0,19
	$\delta_{N\infty}$	[mm/(N/mm <sup>2</sup> )]	0,13	0,20	0,21	0,22	0,19	0,21	0,19	0,21	0,24	0,27
Cracked concrete temperature range II: 70°C / 43°C												
Displacement	$\delta_{N0}$	[mm/(N/mm <sup>2</sup> )]	0,04	0,04	0,07	0,09	0,12	0,17	0,17	0,19	0,21	0,22
	$\delta_{N\infty}$	[mm/(N/mm <sup>2</sup> )]	0,15	0,24	0,25	0,26	0,23	0,24	0,23	0,25	0,28	0,31

**Table C16: Displacements under shear load**

Reinforcing bar (rebar)		φ 8	φ 10	φ 12	φ 14	φ 16	φ 20	φ 25	φ 28	φ 30	φ 32
Displacement	$\delta_{V0}$	[mm/kN]	0,05	0,05	0,05	0,04	0,04	0,04	0,03	0,03	0,03
	$\delta_{V\infty}$	[mm/kN]	0,08	0,08	0,07	0,06	0,06	0,05	0,05	0,05	0,04

**Injection system Hilti HIT-RE 500 V3**

**Performances**  
Displacements

**Annex C20**

**Seismic design shall be carried out according EN 1992-4**

**Table C17: Essential characteristics for threaded rods under tension loads for seismic category C1 in concrete**

Threaded rod, HAS-U-..., HIT-V-..., AM...8.8	M8	M10	M12	M16	M20	M24	M27	M30
<b>Steel failure</b>								
Characteristic resistance $N_{Rk,s,eq}$ [kN]	$A_s \cdot f_{uk}$							
<b>Combined pullout and concrete cone failure for a service life of 50 years</b>								
<b>Cracked concrete C20/25</b> in hammer drilled holes and hammer drilled holes with Hilti hollow drill bit TE-CD or TE-YD and diamond cored holes with roughening with Hilti roughening tool TE-YRT								
Temperature range I: 40°C / 24°C $\tau_{Rk,eq}$ [N/mm <sup>2</sup> ]	6,8	8,0	9,5	9,5	9,5	8,4	9,0	8,5
Temperature range II: 70°C / 43°C $\tau_{Rk,eq}$ [N/mm <sup>2</sup> ]	5,4	6,4	7,5	7,5	7,3	6,9	7,0	6,5
<b>Combined pullout and concrete cone failure for a service life of 100 years</b>								
<b>Cracked concrete C20/25</b> in hammer drilled holes and hammer drilled holes with Hilti hollow drill bit TE-CD or TE-YD and diamond cored holes with roughening with Hilti roughening tool TE-YRT								
Temperature range I: 40°C / 24°C $\tau_{Rk,eq}$ [N/mm <sup>2</sup> ]	5,0	6	6,5	6,5	6	6	5,5	5,5
Temperature range II: 70°C / 43°C $\tau_{Rk,eq}$ [N/mm <sup>2</sup> ]	4,0	5	5,5	5	5	5	4,5	4,0

**Table C18: Essential characteristics for threaded rods under shear loads for seismic category C1 in concrete**

Threaded rod, HAS-U-..., HIT-V-..., AM...8.8	M8	M10	M12	M16	M20	M24	M27	M30
<b>Steel failure without lever arm</b>								
Characteristic resistance HIT-V, AM...8.8 $V_{Rk,s,eq}$ [kN]	$0,5 \cdot A_s \cdot f_{uk}$							
Characteristic resistance Commercial standard threaded rod $V_{Rk,s,eq}$ [kN]	$0,35 \cdot A_s \cdot f_{uk}$							

**Injection system Hilti HIT-RE 500 V3**

**Performances**

Essential characteristics for seismic performance category C1

**Annex C21**

**Table C19: Essential characteristics for internally threaded sleeve HIS-(R)N under tension load for seismic category C1 in concrete**

HIS-(R)N			M8	M10	M12	M16	M20
<b>Steel failure</b>							
HIS-N with screw grade 8.8	$N_{Rk,s,eq}$	[kN]	25	46	67	125	116
Partial factor	$\gamma_{Ms,N,eq}$	[-]	1,5				
HIS-RN with screw grade 70	$N_{Rk,s,eq}$	[kN]	26	41	59	110	166
Partial factor	$\gamma_{Ms,N,eq}$	[-]	1,87				2,4
<b>Combined pullout and concrete cone failure for a service life of 50 years</b>							
<b>Cracked concrete C20/25</b> in hammer drilled holes and hammer drilled holes with Hilti hollow drill bit TE-CD or TE-YD and diamond cored holes with roughening with Hilti roughening tool TE-YRT							
Temperature range I: 40°C / 24°C	$\tau_{Rk,eq}$	[N/mm <sup>2</sup> ]	8,4	8,6	8,7	9	9
Temperature range II: 70°C / 43°C	$\tau_{Rk,eq}$	[N/mm <sup>2</sup> ]	7	6,7	6,8	7	7
<b>Combined pullout and concrete cone failure for a service life of 100 years</b>							
<b>Cracked concrete C20/25</b> in hammer drilled holes and hammer drilled holes with Hilti hollow drill bit TE-CD or TE-YD and diamond cored holes with roughening with Hilti roughening tool TE-YRT							
Temperature range I: 40°C / 24°C	$\tau_{Rk,eq}$	[N/mm <sup>2</sup> ]	5,5	5,5	5,5	6	6
Temperature range II: 70°C / 43°C	$\tau_{Rk,eq}$	[N/mm <sup>2</sup> ]	4,5	4,5	4,5	4,5	4,5

**Table C20: Essential characteristics for internally threaded sleeve HIS-(R)N under shear load for seismic category C1 in concrete**

HIS-(R)N			M8	M10	M12	M16	M20
<b>Steel failure without lever arm</b>							
HIS-N with screw grade 8.8	$V_{Rk,s,eq}$	[kN]	9	16	27	41	39
HIS-RN with screw grade 70	$V_{Rk,s,eq}$	[kN]	9	14	21	39	58

Injection system Hilti HIT-RE 500 V3

**Performances**

Essential characteristics for seismic performance category C1

**Annex C22**

**Table C21: Essential characteristics for Hilti tension anchor HZA / HZA-R under tension load for seismic category C1 in concrete**

HZA / HZA-R		M12	M16	M20	M24	M27
<b>Steel failure</b>						
HZA	$N_{Rk,s,eq}$ [kN]	46	86	135	194	252
HZA-R	$N_{Rk,s,eq}$ [kN]	62	111	173	249	-
Partial factor	$\gamma_{Ms,N,eq}$ [-]	1,4				
<b>Combined pullout and concrete cone failure for a service life of 50 years</b>						
<b>Cracked concrete C20/25</b> in hammer drilled holes and hammer drilled holes with Hilti hollow drill bit TE-CD or TE-YD and diamond cored holes with roughening with Hilti roughening tool TE-YRT						
Temperature range I: 40°C / 24°C	$\tau_{Rk,eq}$ [N/mm <sup>2</sup> ]	8,7	9,5	10	10	11
Temperature range II: 70°C / 43°C	$\tau_{Rk,eq}$ [N/mm <sup>2</sup> ]	7,4	7,5	8,0	8,0	8,0
<b>Combined pullout and concrete cone failure for a service life of 100 years</b>						
<b>Cracked concrete C20/25</b> in hammer drilled holes and hammer drilled holes with Hilti hollow drill bit TE-CD or TE-YD and diamond cored holes with roughening with Hilti roughening tool TE-YRT						
Temperature range I: 40°C / 24°C	$\tau_{Rk,eq}$ [N/mm <sup>2</sup> ]	7,5	7,5	7,5	7,5	7,5
Temperature range II: 70°C / 43°C	$\tau_{Rk,eq}$ [N/mm <sup>2</sup> ]	6,0	5,5	5,5	5,5	5,5

**Table C22: Essential characteristics for Hilti tension anchor HZA / HZA-R under shear load for seismic category C1 in concrete**

HZA / HZA-R		M12	M16	M20	M24	M27
<b>Steel failure without lever arm</b>						
HZA	$V_{Rk,s,eq}$ [kN]	23	43	67	97	126
HZA-R	$V_{Rk,s,eq}$ [kN]	31	55	86	124	-

**Injection system Hilti HIT-RE 500 V3**

**Performances**

Essential characteristics for seismic performance category C1

**Annex C23**

**Table C23: Essential characteristics for reinforcing bars (rebars) under tension load for seismic category C1 in concrete**

Reinforcing bar (rebar)	φ 8	φ 10	φ 12	φ 14	φ 16	φ 20	φ 25	φ 28	φ 30	φ 32
<b>Steel failure rebars</b>										
Rebar B500B acc. to DIN 488:2009-08 <sup>1)</sup> N <sub>Rk,eq</sub> [kN]	-	43	62	85	111	173	270	339	388	442
<b>Combined pullout and concrete cone failure for a service life of 50 years</b>										
<b>Cracked concrete C20/25</b> in hammer drilled holes and hammer drilled holes with Hilti hollow drill bit TE-CD or TE-YD and diamond cored holes with roughening with Hilti roughening tool TE-YRT										
Temperature range I: 40°C / 24°C τ <sub>Rk,eq</sub> [N/mm <sup>2</sup> ]	-	8,2	8,7	9,2	9,5	10,0	10,0	11,0	11,0	11,0
Temperature range II: 70°C / 43°C τ <sub>Rk,eq</sub> [N/mm <sup>2</sup> ]	-	6,8	7,4	7,4	7,5	8,0	8,0	8,0	8,5	8,5
<b>Combined pullout and concrete cone failure for a service life of 100 years</b>										
<b>Cracked concrete C20/25</b> in hammer drilled holes and hammer drilled holes with Hilti hollow drill bit TE-CD or TE-YD and diamond cored holes with roughening with Hilti roughening tool TE-YRT										
Temperature range I: 40°C / 24°C τ <sub>Rk,eq</sub> [N/mm <sup>2</sup> ]	-	7,0	7,5	7,5	7,5	7,5	7,5	7,5	7,0	7,0
Temperature range II: 70°C / 43°C τ <sub>Rk,eq</sub> [N/mm <sup>2</sup> ]	-	5,5	6,0	6,0	5,5	5,5	5,5	5,5	5,0	5,0

<sup>1)</sup> Values need to be calculated acc. EAD 330499-01, Eq. 2.1, if rebars do not fulfil the requirements acc. DIN 488.

**Table C24: Essential characteristics for reinforcing bars (rebars) under shear loads for seismic category C1 in concrete**

Reinforcing bar (rebar)	φ 8	φ 10	φ 12	φ 14	φ 16	φ 20	φ 25	φ 28	φ 30	φ 32
<b>Steel failure without lever arm</b>										
Rebar B500B acc. to DIN 488:2009-08 <sup>1)</sup> V <sub>Rk,eq</sub> [kN]	-	15	22	29	39	60	95	118	135	155

<sup>1)</sup> Values need to be calculated acc. EAD 330499-01, Eq. 2.1, if rebars do not fulfil the requirements acc. DIN 488.

**Injection system Hilti HIT-RE 500 V3**

**Performances**

Essential characteristics for seismic performance category C1

**Annex C24**

**Table C25: Essential characteristics for threaded rod under tension load for seismic category C2 in concrete**

Threaded rod, HAS-U-..., HIT-V-..., AM...8.8	M8	M10	M12	M16	M20	M24	M27	M30	
<b>Steel failure threaded rods</b>									
HAS-U 8.8, HAS-U-F 8.8, HIT-V 8.8, HIT-V-F 8.8, AM 8.8, AM-HDG 8.8, Commercial standard threaded rod electroplated zinc coated	$N_{Rk,s,eq}$ [kN]			$A_s \cdot f_{uk}$					
<b>Combined pullout and concrete cone failure for a service life of 50 years</b>									
<b>Cracked concrete C20/25</b> in hammer drilled holes and hammer drilled holes with Hilti hollow drill bit TE-CD or TE-YD									
Temperature range I: 40°C / 24°C	$\tau_{Rk,eq}$ [N/mm <sup>2</sup> ]	-	-	-	5,9	5,4	5,1	5,0	5,2
Temperature range II: 70°C / 43°C	$\tau_{Rk,eq}$ [N/mm <sup>2</sup> ]	-	-	-	4,4	4,1	3,9	3,7	3,9
<b>Combined pullout and concrete cone failure for a service life of 100 years</b>									
<b>Cracked concrete C20/25</b> in hammer drilled holes and hammer drilled holes with Hilti hollow drill bit TE-CD or TE-YD									
Temperature range I: 40°C / 24°C	$\tau_{Rk,eq}$ [N/mm <sup>2</sup> ]	-	-	-	5,9	5,4	5,1	5,0	5,2
Temperature range II: 70°C / 43°C	$\tau_{Rk,eq}$ [N/mm <sup>2</sup> ]	-	-	-	4,4	4,1	3,9	3,7	3,9

**Table C26: Essential characteristics for threaded rods under shear loads for seismic category C2 in concrete**

Threaded rod, HAS-U-..., HIT-V-..., AM...8.8	M8	M10	M12	M16	M20	M24	M27	M30			
<b>Steel failure without lever arm, using Hilti filling set</b>											
HAS-U 8.8, HIT-V 8.8, AM 8.8	$V_{Rk,s,eq}$ [kN]			-	-	-	46	77	103	-	-
<b>Steel failure without lever arm, without using Hilti filling set</b>											
HAS-U 8.8, HIT-V 8.8, AM 8.8	$V_{Rk,s,eq}$ [kN]			-	-	-	40	71	90	121	135
HAS-U-F 8.8, HIT-V-F 8.8, AM-HDG 8.8	$V_{Rk,s,eq}$ [kN]			-	-	-	30	46	66	-	-
Commercial standard threaded rod electroplated zinc coated 8.8	$V_{Rk,s,eq}$ [kN]			-	-	-	28	50	63	85	101

**Injection system Hilti HIT-RE 500 V3**

**Performances**

Essential characteristics for seismic performance category C2

**Annex C25**

**Table C27: Displacement for threaded rods under tension loads for seismic category C2 in concrete**

Threaded rod, HAS-U-..., HIT-V-..., AM...8.8	M8	M10	M12	M16	M20	M24	M27	M30
Displacement DLS $\delta_{N,eq(DLS)}$ [mm]	-	-	-	0,5	0,5	0,4	0,4	0,5
Displacement ULS $\delta_{N,eq(ULS)}$ [mm]	-	-	-	1,2	0,9	0,8	1,0	0,9

**Table C28: Displacement for threaded rods under shear loads for seismic category C2 in concrete**

Threaded rod, HAS-U-..., HIT-V-..., AM...8.8	M8	M10	M12	M16	M20	M24	M27	M30
<b>Installation with seismic filling set</b>								
Displacement DLS, HAS-U 8.8, HIT-V 8.8, AM 8.8 $\delta_{V,eq(DLS)}$ [mm]	-	-	-	1,2	1,4	1,1	-	-
Displacement ULS, HAS-U 8.8, HIT-V 8.8, AM 8.8 $\delta_{V,eq(ULS)}$ [mm]	-	-	-	3,2	3,7	2,6	-	-
<b>Installation without seismic filling set</b>								
Displacement DLS, HAS-U 8.8, HIT-V 8.8, AM 8.8 $\delta_{V,eq(DLS)}$ [mm]	-	-	-	3,2	2,5	3,5	3,0	1,9
Displacement DLS, HAS-U-F 8.8, HIT-V-F 8.8, AM-HDG 8.8 $\delta_{V,eq(DLS)}$ [mm]	-	-	-	2,3	3,8	3,4	-	-
Displacement ULS, HAS-U 8.8, HIT-V 8.8, AM 8.8 $\delta_{V,eq(ULS)}$ [mm]	-	-	-	9,2	7,1	10,2	7,2	6,3
Displacement ULS, HAS-U-F 8.8, HIT-V-F 8.8, AM-HDG 8.8 $\delta_{V,eq(ULS)}$ [mm]	-	-	-	4,3	9,1	8,4	-	-

**Injection system Hilti HIT-RE 500 V3**

**Performances**

Displacements for seismic performance category C2

**Annex C26**