



● Compliance with International Codes  
● Compliance to State/Regional Codes

## ICC-ES Evaluation Report

Reissued January 2022

### ESR-4143

This report is subject to renewal January 2023.

**DIVISION: 04 00 00—MASONRY**  
**Section: 04 05 19.16—Masonry Anchors**

**REPORT HOLDER:**

HILTI, INC.

**EVALUATION SUBJECT:**

HILTI HIT-HY 270 ADHESIVE ANCHOR SYSTEM

#### 1.0 EVALUATION SCOPE

**Compliance with the following codes:**

- 2018, 2015, 2012 and 2009 *International Building Code*® (IBC)
- 2018, 2015, 2012 and 2009 *International Residential Code*® (IRC)
- 2013 *Abu Dhabi International Building Code* (ADIBC)<sup>†</sup>

<sup>†</sup>The ADIBC is based on the 2009 IBC. 2009 IBC code sections referenced in this report are the same sections in the ADIBC.

For evaluation for compliance with codes adopted by the Los Angeles Department of Building Safety (LADBS), see [ESR-4143 LABC and LARC Supplement](#).

**Property evaluated:**

Structural

#### 2.0 USES

The Hilti HIT-HY 270 Adhesive Anchor System is used to anchor building components to hollow (ungrouted) and fully grouted concrete masonry walls, and hollow (ungrouted) brick masonry walls. Threaded rods, steel reinforcing bars, and internally threaded inserts installed with Hilti HIT-HY 270 can resist static, wind, and earthquake loads, as noted in Section 4.0 of this evaluation report. The anchor system is an alternative to Section 8.1.3 (2016 or 2013 editions) or Section 2.1.4 (2011, 2008 or 2005 editions) of TMS 402/ ACI 530/ ASCE 5, as applicable, as referenced in Section 2107 of the IBC. The anchor system may also be used where an engineered design is submitted in accordance with Section R301.1.3 of the IRC.

#### 3.0 DESCRIPTION

##### 3.1 General:

The Hilti HIT-HY 270 Adhesive Anchor System is comprised of the following components:

- Hilti HIT-HY 270 adhesive
- All-threaded steel rods, steel reinforcing bars, or Hilti HIS steel internally threaded inserts (grout-filled concrete masonry)
- All-threaded rods, bolts, cap screws, studs, Hilti HIT-IC internally threaded inserts, and Hilti HIT-SC plastic-mesh screen tubes (hollow concrete masonry and hollow brick masonry)

##### 3.2 Materials:

**3.2.1 Hilti HIT-HY 270 Adhesive:** The Hilti HIT-HY 270 is an injectable hybrid adhesive mortar consisting of urethane methacrylate resin, hardener, cement and water. The resin and cement are separated from the hardener and water by means of a dual-cylinder foil pack attached to a manifold. An injection nozzle with an internal mixing element is attached to the manifold, and the adhesive components are dispensed through the injection nozzle to ensure their proper mixing. The injection nozzle may be replaced to permit interruptions in the use of the cartridges. Available cartridge sizes include total mixed volumes of 11.1 ounces (330 mL) and 16.9 ounces (500 mL).

The adhesive expiration date is printed on the manifold of each foil pack (month/year). The shelf life, as indicated by the expiration date, is for an unopened foil pack stored in a cool, dry, dark environment at temperatures between 41°F and 77°F (5°C and 25°C). Gel and curing times for the Hilti HIT-HY 270 adhesive, and the respective masonry temperature during installation and cure, are shown in Tables 1A and 1B.

##### 3.2.2 Hole Cleaning Equipment:

**3.2.2.1 Standard Equipment:** Standard hole cleaning equipment, comprised of steel wire brushes and air nozzles is described in Figure 5 of this report.

**3.2.2.2 Hilti Safe-Set™ System:** When the Hilti TE-CD or TE-YD hollow carbide drill with a carbide drilling head conforming to ANSI B212.15 is used in conjunction with a Hilti vacuum with a minimum value for the maximum

volumetric flow rate of 129 CFM (61  $\ell$ /s), the Hilti TE-CD or TE-YD drill bit will remove drilling dust, automatically cleaning the hole.

**3.2.3 Threaded Steel Rods (For Use in Fully Grouted Concrete Masonry and with Plastic Mesh Screen Tubes in Hollow Masonry):** Threaded rods, having diameters described in Tables 3A through 10 of this report, must be clean, continuously threaded rods (all-thread). Carbon steel threaded rods must be in accordance with ASTM A36, ASTM A307, ASTM A193 Grade B7, ISO 898 Class 5.8. Stainless steel threaded rods must conform to ASTM F593 (AISI 304 or 316), Condition CW. Threaded steel rods must be straight and free of indentations or other defects along their lengths. The ends may be stamped with identifying marks and the embedded end may be blunt cut or cut on the bias (chisel point).

**3.2.4 Steel Reinforcing Bars (For Use in Fully Grouted Concrete Masonry):** Steel reinforcing bars are deformed reinforcing bars (rebar) having diameters described in Tables 3A, 3B, 5B, 5D, and 11 of this report, and must comply with ASTM A615, Grade 60. The embedded portions of reinforcing bars must be straight, and free of mill scale, rust, mud, oil, and other coatings that impair the bond with the adhesive.

**3.2.5 HIT-SC Screen Tubes:** The Hilti HIT-SC plastic-mesh screen tubes are used in hollow masonry as described in Sections 3.4, 3.5, and 5.6 of this report. The screens consist of a removable cap, a collar, and a plastic mesh tube.

**3.2.6 HIT-IC Inserts (For Use With Plastic Mesh Screens in Hollow Masonry):** Hilti HIT-IC are steel internally threaded inserts conforming to DIN 10277-3 and are available in  $5/16$ -,  $3/8$ -, and  $1/2$ -inch (7.9, 9.5, and 12.7 mm) internal thread diameters. Common threaded rods as per Section 3.2.3, or bolts, cap screws, and studs conforming to SAE J995, ASTM A563 C, C3, D, DH, DH3 Heavy Hex, and ASTM F594, can be used with internally threaded inserts.

**3.2.7 HIS-N and HIS-RN Inserts (For Use in Fully Grouted Concrete Masonry):** Hilti HIS-(R)N steel inserts have a profile on the external surface and are internally threaded. Inserts are available in  $3/8$ - and  $1/2$ -inch (9.5 and 12.7 mm) internal thread diameters. HIS-(R)N inserts are produced from carbon steel and furnished either with a 0.005-millimeter-thick (5 mm) zinc electroplated coating complying with ASTM B633 SC 1 or a hot-dipped galvanized coating complying with ASTM A153, Class C or D. The stainless steel HIS-RN inserts conform to DIN 10088-3. Common threaded rods as per Section 3.2.3, or bolts, cap screws, and studs conforming to SAE J995, ASTM A563 C, C3, D, DH, DH3 Heavy Hex, and ASTM F594 can be used with internally threaded inserts.

**3.3 Fully Grouted Concrete Masonry:** Fully grouted concrete masonry must comply with Chapter 21 of the IBC. The compressive strength of masonry,  $f_m$ , at 28 days must be a minimum of 1,500 psi (10.3 MPa). Fully grouted masonry systems must be constructed from the following materials:

**3.3.1 Concrete Masonry Units (CMUs):** CMUs must be minimum Grade N, Type 1, light-, medium-, or normal-weight conforming to ASTM C90. The minimum nominal size of the CMUs must be 8 inches wide by 8 inches high by 16 inches long.

**3.3.2 Grout:** Grout must comply with 2018 and 2015 IBC Section 2103.3, 2012 IBC Section 2103.13, and 2009 IBC Section 2103.12, or 2018 IRC Section R606.2.12, 2015 IRC Section R606.2.11, 2012 and 2009 IRC Section R609.1.1,

as applicable. Alternatively, the grout must have a minimum compressive strength, when tested in accordance with ASTM C1019, equal to its specified strength, but not less than 2,000 psi (13.8 MPa).

**3.3.3 Mortar:** Mortar must be Type N (minimum) in accordance with IBC Section 2103, or 2018 IRC Section R606.2.8, 2015 IRC Section R606.2.7, or 2012 and 2009 IRC Section R607, as applicable.

**3.4 Hollow (Ungrouted) Concrete Masonry:** Hollow concrete masonry must comply with Chapter 21 of the IBC. The compressive strength of masonry,  $f_m$ , at 28 days must be a minimum of 1,500 psi (10.3 MPa). Hollow concrete masonry walls must be constructed from the following materials:

**3.4.1 Concrete Masonry Units (CMUs):** CMUs must be minimum Grade N, Type 1, light-, medium-, or normal-weight conforming to ASTM C90. The minimum nominal size of the CMUs must be 8 inches wide by 8 inches high by 16 inches long.

**3.4.2 Mortar:** Mortar must be Type N (minimum) in accordance with IBC Section 2103, or 2018 IRC Section R606.2.8, 2015 IRC Section R606.2.7 or 2012 and 2009 IRC Section R607, as applicable.

**3.5 Hollow Brick Masonry:** Hollow brick masonry must comply with Chapter 21 of the IBC. The compressive strength of masonry,  $f_m$ , at 28 days must be a minimum of 3,000 psi (20.7 MPa). Hollow brick masonry walls must be a minimum of two-wythes in thickness, and constructed from the following materials:

**3.5.1 Brick Masonry Units:** Hollow brick masonry must be constructed using hollow bricks conforming to ASTM C652, Grade SW. The minimum nominal size of the brick masonry units must be  $3\frac{5}{8}$  inches (92 mm) wide by  $2\frac{1}{4}$  inches (57 mm) high by  $7\frac{5}{8}$  inches (194 mm) long.

**3.5.2 Mortar:** Mortar must be Type N (minimum) in accordance with IBC Section 2103, or 2018 Section R606.2.8, 2015 Section R606.2.7 or 2012 and 2009 IRC Section R607, as applicable.

## 4.0 DESIGN AND INSTALLATION

### 4.1 Design:

**4.1.1 General:** Anchors described in this report are assigned allowable tension and shear load values based on allowable stress design (ASD), as an alternative to Section 8.1.3 (2018 or 2013 editions) or Section 2.1.4 (2011, 2008 or 2005 editions) of TMS 402/ ACI 530/ ASCE 5, as applicable, as referenced in Section 2107 of the IBC. For use under the IRC, an engineered design in accordance with Section R301.1.3 must be submitted to the code official. The allowable tension and shear values reported herein must be adjusted in accordance with Figure 1 for in-service base-material temperatures in excess of 70°F (21°C). Anchors installed or cured at temperatures below 23°F (-5°C) are outside the scope of this report. Allowable tension and shear loads based on steel strength for threaded rods are described in Table 10, and for reinforcing bars are described in Table 11.

Allowable stress design tension and shear load values in Tables 3A, 3B, 5A, 5B, 5C and 5D may be used for resistance to short-term loads such as wind and seismic, in accordance with Section 5.5 and Table 2 of this report. Use of the values in the remaining tables for seismic loads is beyond the scope of this report. Use of the values in the remaining tables may be used for short-term loading due to wind forces; however, the allowable loads must not be increased.

**4.1.2 Combined Loading:** Allowable loads for anchors installed in masonry and subjected to combined tension and shear forces must be determined by the following formula:

$$\left(\frac{P_s}{P_t}\right)^n + \left(\frac{V_s}{V_t}\right)^n \leq 1.0$$

where:

$P_s$  = Applied service tension load (lbf or kN).

$P_t$  = Allowable service tension load (lbf or kN).

$V_s$  = Applied service shear load (lbf or kN).

$V_t$  = Allowable service shear load (lbf or kN).

$n = 5/3$  for the  $3/8$ - and  $1/2$ -inch-diameter steel threaded rods, No. 3 and No. 4 reinforcing bars, and  $3/8$ - and  $1/2$ -inch-diameter Hilti HIS steel internally threaded inserts installed in the face of grout filled concrete masonry.

$n = 1$  for the  $5/8$ - and  $3/4$ -inch-diameter steel threaded rods and No. 5 and No. 6 reinforcing bars installed in the face of grout filled concrete masonry, and all diameters of threaded rod and reinforcing bar installed in the top of grout filled concrete masonry, and all threaded rods and inserts in hollow (ungrouted) concrete masonry, and brick masonry.

**4.1.3 Design of Threaded Rods and Reinforcing Bars Installed in the Face of Fully Grouted CMU Walls:**

Allowable tension and shear load values for  $3/8$ -,  $1/2$ -,  $1/2$ -, and  $3/4$ -inch-diameter (9.5, 12.7, 15.9, and 19.1 mm) steel threaded rods and No. 3, 4, 5, and 6 reinforcing bars installed in the face of grout-filled CMU walls are reported in Tables 3A and 3B. The allowable tension and shear loads are for anchors installed in any location in the face of the grout-filled CMU walls (cell, web, joints), and resisting static, wind, or earthquake loads. Critical and minimum spacing and edge distances, with appropriate reduction factors, are given in Tables 3A and 3B and shown in Figure 2.

**4.1.4 Design of Threaded Rods and Reinforcing Bars Installed in the Top or Side of Fully Grouted CMU Walls:**

Allowable tension and shear load values for  $1/2$ -,  $5/8$ - and  $3/4$ -inch-diameter (12.7 mm, 15.9 mm, and 19.1 mm) steel threaded rods and No. 4 and No. 5 reinforcing bars installed in the top or side of grout-filled CMU walls and resisting static, wind, or earthquake loads are reported in Table 5A through Table 5D. Minimum edge and end distances are noted in Table 5A through Table 5D and shown in Figures 3 and 4.

**4.1.5 Design of HIS-N and HIS-RN Inserts Installed in the Face of Fully Grouted CMU Walls:**

Allowable tension and shear load values for  $3/8$ -inch and  $5/8$ -inch (9.5 and 12.7 mm) HIS-N and HIS-RN internally threaded inserts installed in the face of fully grouted CMU walls are reported in Tables 4A and 4B. The allowable tension and shear loads are for HIS-(R)N inserts installed in any location in the face of the fully grouted CMU walls (cell, web, joints), and resisting static and wind load applications only. Use of these anchors to resist earthquake loads is outside the scope of this report. Critical and minimum spacing and edge distances, with appropriate reduction factors, are also given in Tables 4A and 4B.

**4.1.6 Design of Anchors in Hollow Concrete Masonry Walls:**

Allowable tension and shear load values for  $1/4$ -,  $5/16$ -,  $3/8$ -,  $1/2$ -inch-diameter (6.4, 7.9, 9.5, 12.7 mm) steel threaded rods and  $5/16$ -inch,  $3/8$ -inch, and  $1/2$ -inch (7.9, 9.5, 12.7 mm) HIT-IC internally threaded inserts installed with Hilti HIT-SC plastic screens through the face of hollow concrete masonry walls are reported in Tables 6 and 7. The allowable tension and shear loads are for anchors resisting static and wind load applications only. Use of these anchors to resist earthquake loads is outside the scope of this report.

Critical and minimum spacing and edge distances are also given in Tables 6 and 7.

**4.1.7 Design of Anchors in Hollow Brick Masonry Walls:**

Allowable tension and shear load values for  $1/4$ -,  $5/16$ -,  $3/8$ -,  $1/2$ -inch-diameter (6.4, 7.9, 9.5, 12.7 mm) steel threaded rods and  $5/16$ -inch,  $3/8$ -inch, and  $1/2$ -inch (7.9, 9.5, 12.7 mm) HIT-IC internally threaded inserts installed with Hilti HIT-SC plastic screens through the face of hollow brick masonry walls are reported in Tables 8A, 8B and 9. The allowable tension and shear loads are for anchors resisting static and wind load applications only. Use of these anchors to resist earthquake loads is outside the scope of this report. Critical and minimum spacing and edge distances are also given in Tables 8A, 8B, and 9.

**4.2 Installation:**

Installation parameters are illustrated in Figure 5. Installation of the Hilti HIT-HY 270 Adhesive Anchor System must conform to the manufacturer's printed installation instruction (MPII) included in each unit package as provided in Figure 5 of this report. Anchor locations must comply with this report and the plans and specifications approved by the code official.

**4.3 Special Inspection**

Periodic special inspections are required in accordance with IBC Sections 1704 and 1705, and are also applicable for installations under the IRC.

The approved special inspector must be on the jobsite initially during anchor installation to verify anchor type, anchor dimensions, adhesive identification and expiration date, masonry type, masonry compressive strength, hole dimensions, hole cleaning procedures, anchor spacing, edge distances, masonry wall thickness, anchor embedment, tightening torque, base-material temperature, and adherence to the manufacturer's printed installation instructions (MPII).

The special inspector must verify the initial installations of each type and size of adhesive anchor by construction personnel on the site.

Subsequent installations of the same anchor type and size by the same construction personnel are permitted to be performed in the absence of the special inspector. Any change in the anchor product being installed or the personnel performing the installation requires an initial inspection. For ongoing installations over an extended period, the special inspector must make regular inspections to confirm correct handling and installation of the product.

**5.0 CONDITIONS OF USE**

The Hilti HIT-HY 270 Adhesive Anchor System described in this report complies with, or is a suitable alternative to what is specified in, those codes listed in Section 1.0 of this report, subject to the following conditions:

- 5.1** The Hilti HIT-HY 270 Adhesive Anchor System must be installed in accordance with the manufacturer's printed installation instructions (MPII) and this report. In case of conflict, this report governs.
- 5.2** Anchor sizes, dimensions, and minimum embedment depths must be as set forth in this report.
- 5.3** Prior to installation, calculations and details demonstrating compliance with this report must be submitted to the code official for approval. The calculations must be prepared by a registered design professional when required by the statutes of the jurisdiction in which the project is to be constructed.
- 5.4** Anchors resisting static, seismic or wind loads in masonry must be designed in accordance with Section 4.0 of this report.
- 5.5** Grout-filled concrete masonry under the IBC or the IRC (Tables 3A, 3B, 5A, 5B, 5C, and 5D): The adhesive

anchors described in Sections 4.1.3 and 4.1.4 of this evaluation report are capable of resisting seismic and wind loads. When using the basic load combinations in accordance with IBC Section 1605.3.1, allowable loads must not be increased for seismic or wind loading. When using the alternative basic load combinations in 2009 IBC Section 1605.3.2 that include seismic or wind loads, the allowable loads may be increased in accordance with Table 2, or the alternative basic load combinations may be decreased by the factors in Table 2, as applicable. For the 2018, 2015 and 2012 IBC, the allowable loads or load combinations must not be adjusted.

- 5.6** HIS-N and HIS-RN inserts (Tables 4A and 4B), hollow concrete masonry (Tables 6 and 7), and hollow brick masonry (Tables 8A, 8B, and 9) under the IBC or the IRC: Use of the adhesive anchors described in Sections 4.1.5, 4.1.6, and 4.1.7 for resistance to seismic loads is beyond the scope of this report. The allowable loads or load combinations for these anchors must not be adjusted for applications subjected to wind loads.
- 5.7** Since an ICC-ES acceptance criteria for evaluating data to determine the performance of adhesive anchors subjected to fatigue or shock loading is unavailable at this time, the use of these anchors under these conditions is beyond the scope of this report.
- 5.8** The Hilti HIT-HY 270 Adhesive Anchor Systems may be used to resist tension and shear forces in wall installations only if consideration is given to the effects of elevated temperature conditions on anchor performance. Figure 1 describes load reduction factors for elevated temperatures.
- 5.9** Anchors are not permitted to support fire-resistive construction. Where not otherwise prohibited by the code, anchors are permitted for installation in fire-resistive construction provided that at least one of the following conditions is fulfilled:
- Anchors are used to resist wind or seismic forces only.
  - Anchors that support gravity load-bearing structural elements are within a fire-resistive envelope or a fire-resistive membrane, are protected by approved fire-resistive materials, or have been evaluated for resistance to fire exposure in accordance with recognized standards.
  - Anchors are used to support nonstructural elements.
- 5.10** Since an ICC-ES acceptance criteria for evaluating the performance of adhesive anchors in cracked masonry is unavailable at this time, the use of anchors is limited to installation in uncracked masonry. Cracking occurs when  $f_t > f_r$ , due to service loads or deformations.
- 5.11** Use of Hilti HIT-HY 270 Adhesive Anchor System in conjunction with uncoated or zinc electroplated carbon steel threaded rods or steel reinforcing bars must be limited to interior exposure. Use of stainless steel (AISI 304 or 316) anchors or hot dipped galvanized anchors with a zinc coating conforming to ASTM A153, Class C or D, is permitted for exterior or damp environments.
- 5.12** The Hilti HIT-HY 270 Adhesive Anchor System may be installed in base materials having interior temperatures between 23°F (-5°C) and 104°F (40°C) at the time of installation. Installation of HIT-HY 270 adhesive in base materials having temperatures beyond this range is outside the scope of this report.
- 5.13** When anchors are located where the base-material temperature may exceed 70°F (21°C), allowable tension and shear loads indicated in this report must be adjusted for in-service temperatures in accordance with Figure 1. The use of HIT-HY 270 adhesive in base materials having interior temperatures exceeding 180°F (82°C) during their service life is outside the scope of this report.
- 5.14** Steel anchoring materials in contact with preservative-treated wood or fire-retardant-treated wood must be stainless steel or hot-dipped galvanized in accordance with ASTM A153 Class C or D.
- 5.15** Special inspection in accordance with Section 4.3 of this report must be provided for all anchor installations.
- 5.16** The Hilti HIT-HY 270 Adhesive Anchor Systems must be installed in holes created using a carbide-tipped masonry drill bit manufactured within the range of the maximum and minimum dimensions of ANSI B212.15.
- 5.17** The Hilti HIT-HY 270 adhesive is manufactured by Hilti GmbH at their facilities in Kaufering, Germany, under a quality control program with inspections by ICC-ES.
- 5.18** The Hilti HIT-SC plastic screens are manufactured by Hilti Kunststofftechnik GmbH, Nersingen, Germany, with quality control inspections by ICC-ES.
- 5.19** The Hilti HIT-IC inserts are manufactured by Hilti (China) Ltd., Guangdong, China, with quality control inspections by ICC-ES.
- 5.20** The Hilti HIS-N and HIS-RN inserts are manufactured by Hilti (China) Ltd., Guangdong, China, with quality control inspections by ICC-ES.

## 6.0 EVIDENCE SUBMITTED

- 6.1** Data in accordance with the ICC-ES Acceptance Criteria for Adhesive Anchors in Masonry Elements (AC58), dated March 2018, including tests on the effects of edge distance (Test Series 4 and 5), end distance (Test Series 5), spacing (Test Series 8 and 9) on tension performance; the effects of end distance (Test Series 14), spacing and edge distance (Test Series 13 and 14) on shear performance; for installations in grout-filled CMU, hollow concrete, and/or hollow brick masonry walls; the effects of oblique tension loading (Test Series 15); and suitability tests (Test Series 17 through 21) for installations in grout-filled CMU walls.
- 6.2** A quality-control manual.

## 7.0 IDENTIFICATION

- 7.1** The Hilti HIT-HY 270 adhesive cartridges are identified by a label displaying the product name, name of the manufacturer (Hilti, Inc.), lot number, expiration date, description of the product, and evaluation report number (ICC-ES ESR-4143).
- 7.2** The Hilti HIT-SC plastic screens are identified by a packaging label displaying the product name, name of the manufacturer (Hilti Inc.), description of the product, and evaluation report number (ICC-ES ESR-4143).
- 7.3** The Hilti HIS-N and HIS-RN inserts are identified by a packaging label displaying the product name, name of the manufacturer (Hilti Inc.), description of the product, and evaluation report number (ICC-ES ESR-4143).
- 7.4** The Hilti HIT-IC inserts are identified by a packaging label displaying the product name, name of the manufacturer (Hilti Inc.), description of the product, and evaluation report number (ICC-ES ESR-4143).

7.5 Threaded rods, reinforcing bars, nuts, washers, bolts, cap screws, and studs are standard elements, and must conform to applicable national or international specifications and this report.

7.6 The report holder's contact information is the following:

**HILTI, INC.**  
**7250 DALLAS PARKWAY, SUITE 1000**  
**PLANO, TEXAS 75024**  
**(800) 879-8000**  
[www.us.hilti.com](http://www.us.hilti.com)

**TABLE 1A—HILTI, INC., GEL AND CURE TIMES FOR HIT-HY 270 ADHESIVE IN CONCRETE MASONRY**

Base-Material Temperature		Approximate Gel Time <sup>1</sup>	Approximate Curing Time
°F	°C		
23 – 32	-5 – 0	10 Minutes	6 hours
33 – 41	1 – 5	10 Minutes	4 hours
42 – 50	6 – 10	7 Minutes	2.5 hours
51 – 68	11 – 20	4 Minutes	1.5 hours
69 – 86	21 – 30	2 Minutes	30 minutes
87 – 104	31 – 40	1 Minutes	20 minutes

For SI:  $t\text{ }^{\circ}\text{C} = 5/9 \cdot (t\text{ }^{\circ}\text{F} - 32\text{ }^{\circ}\text{F})$

**TABLE 1B—HILTI, INC., GEL AND CURE TIMES FOR HIT-HY 270 ADHESIVE IN CLAY MASONRY**

Base-Material Temperature		Approximate Gel Time <sup>1</sup>	Approximate Curing Time
°F	°C		
41	5	10 Minutes	4 hours
42 – 50	6 – 10	7 Minutes	2.5 hours
51 – 68	11 – 20	4 Minutes	1.5 hours
69 – 86	21 – 30	2 Minutes	30 minutes
87 – 104	31 – 40	1 Minutes	20 minutes

For SI:  $t\text{ }^{\circ}\text{C} = 5/9 \cdot (t\text{ }^{\circ}\text{F} - 32\text{ }^{\circ}\text{F})$

**TABLE 2—ALTERNATIVE BASIC LOAD COMBINATION ADJUSTMENT FACTORS<sup>1,2,3</sup>**

Steel Type	Modification Factors			
	Reductions for Alternate Basic Load Combinations		Increase Factor for Allowable Loads for Short-term Loading Conditions	
	Tension	Shear	Tension	Shear
Standard threaded rods and inserts	0.75	0.75	1.33	1.33
High-strength rods	0.75	1	1.33	1
Stainless rods and inserts	0.75	0.87	1.33	1.14
Steel reinforcing bars	0.75	0.75	1.33	1.33

<sup>1</sup> When using the basic load combinations in accordance with IBC Section 1605.3.1, allowable loads must not be increased for wind or seismic loading.

<sup>2</sup> When using the alternative basic load combinations in the 2009 IBC Section 1605.3.2 that include wind or seismic loads, the allowable loads for anchors may be increased by the tabulated factors found in the right half of the table. Alternatively, the alternate basic load combinations may be reduced by multiplying them by the reduction factors found in the left half of the table. For example, for stainless steel rods in shear, the alternate basic loads for wind or seismic may be multiplied by 0.87 for shear loading or divided by 1.14 ( $1/1.14 = 0.87$ ), as applicable. For the 2018, 2015, 2012 IBC, the allowable loads or load combinations must not be adjusted.

<sup>3</sup> The above modification factors are applicable under the 2009 IBC only, for Tables 3A, 3B, 5A, 5B, 5C, and 5D of this report for seismic loads, and Tables 3A, 3B, 4A, 4B, 5A, 5B, 5C, 5D, 6, 7, 8A, 8B, 9, 10, and 11 of this report for wind loads.

**TABLE 3A—ALLOWABLE ADHESIVE BOND TENSION LOADS FOR THREADED RODS AND REINFORCING BARS IN THE FACE OF GROUT-FILLED CONCRETE MASONRY UNITS (POUNDS)**<sup>1,2,7,8,9,11,12,13</sup>

Anchor Diameter (inches), or Rebar Size	Embedment (inches) <sup>3</sup>	Load @ $c_{cr}$ and $s_{cr}$	Spacing <sup>4</sup>			Edge Distance <sup>5</sup>		
			Critical, $s_{cr}$ (inches)	Minimum, $s_{min}$ (inches)	Load Reduction Factor at $s_{min}$ <sup>6</sup>	Critical, $c_{cr}$ (inches)	Minimum, $c_{min}$ (inches)	Load Reduction Factor at $c_{min}$ <sup>6</sup>
<sup>3</sup> / <sub>8</sub> or No. 3	3 <sup>3</sup> / <sub>8</sub>	1240	13.5	4	0.70	12	4	0.80
<sup>1</sup> / <sub>2</sub> or No. 4	4 <sup>1</sup> / <sub>2</sub>	2035	18	4	0.70	20	4	0.76
<sup>5</sup> / <sub>8</sub> or No. 5	5 <sup>5</sup> / <sub>8</sub>	2840	22.5	4	0.50	20	4	0.71
<sup>3</sup> / <sub>4</sub> or No. 6	6 <sup>3</sup> / <sub>4</sub>	3810	27	4	0.50	20	4	0.66

**TABLE 3B—ALLOWABLE ADHESIVE BOND SHEAR LOADS FOR THREADED RODS AND REINFORCING BARS IN THE FACE OF GROUT-FILLED CONCRETE MASONRY UNITS (POUNDS)**<sup>1,2,7,8,9,10,11,12,13</sup>

Anchor Diameter (inches)	Embedment (inches) <sup>3</sup>	Load @ $c_{cr}$ and $s_{cr}$	Spacing <sup>4</sup>			Edge Distance <sup>5</sup>			
			Critical, $s_{cr}$ (inches)	Minimum, $s_{min}$ (inches)	Load Reduction Factor at $s_{min}$ <sup>6</sup>	Critical, $c_{cr}$ (inches)	Minimum, $c_{min}$ (inches)	Load Reduction Factor at $c_{min}$ <sup>6</sup>	
								Load Perpendicular to Edge	Load Parallel to Edge
<sup>3</sup> / <sub>8</sub> or No. 3	3 <sup>3</sup> / <sub>8</sub>	850	13.5	4	1.00	12	4	0.88	1.00
<sup>1</sup> / <sub>2</sub> or No. 4	4 <sup>1</sup> / <sub>2</sub>	1495	18	4	1.00	12	4	0.49	1.00
<sup>5</sup> / <sub>8</sub> or No. 5	5 <sup>5</sup> / <sub>8</sub>	2615	22.5	4	0.50	20	4	0.40	0.78
<sup>3</sup> / <sub>4</sub> or No. 6	6 <sup>3</sup> / <sub>4</sub>	4090	27	4	0.50	20	4	0.26	0.60

For **SI**: 1 inch = 25.4 mm, 1 lbf = 4.45 N, 1 psi = 6.89 kPa.

**The following footnotes apply to both Tables 3A and 3B:**

- <sup>1</sup> All values are for anchors installed in fully grouted concrete masonry with minimum masonry strength of 1500 psi. Concrete masonry units must be light-, medium-, or normal-weight conforming to ASTM C90. Allowable loads have been calculated using a safety factor of 5.
- <sup>2</sup> Anchors may be installed in any location in the face of the masonry wall (cell, web, joints). Anchors are limited to one per masonry cell.
- <sup>3</sup> Embedment depth is measured from the outside face of the concrete masonry unit.
- <sup>4</sup> The critical spacing,  $s_{cr}$ , is the anchor spacing where full load values in the table may be used. The minimum spacing,  $s_{min}$ , is the minimum anchor spacing for which values are available and installation is recommended. Spacing is measured from the center of one anchor to the center of an adjacent anchor.
- <sup>5</sup> The critical edge distance,  $c_{cr}$ , is the edge distance where full load values in the table may be used. The minimum edge distance,  $c_{min}$ , is the minimum edge distance for which values are available and installation is permitted. Edge distance is measured from the center of the anchor to the closest edge (See Figure 2).
- <sup>6</sup> Load reduction factors are multiplicative; both spacing and edge distance load reduction factors must be considered.
- <sup>7</sup> Load values for anchors installed at less than  $s_{cr}$  and  $c_{cr}$  must be multiplied by the appropriate load reduction factor based on actual edge distance (c) or spacing (s).
- <sup>8</sup> Linear interpolation of load values between minimum spacing ( $s_{min}$ ) and critical spacing ( $s_{cr}$ ) and between minimum edge distance ( $c_{min}$ ) and critical edge distance ( $c_{cr}$ ) is permitted.
- <sup>9</sup> Concrete masonry thickness must be equal to or greater than 1.5 times the anchor embedment depth. EXCEPTION: the <sup>5</sup>/<sub>8</sub>-inch- and the <sup>3</sup>/<sub>4</sub>-inch-diameter anchors and No.5 and No. 6 reinforcing bars may be installed in minimum nominally 8-inch-thick concrete masonry.
- <sup>10</sup> When using the basic load combinations in accordance with IBC Section 1605.3.1, tabulated allowable loads must not be increased for seismic or wind loading. When using the alternative basic load combinations in the 2009 IBC Section 1605.3.2 that include seismic or wind loads, tabulated allowable loads may be increased, or the alternative basic load combinations may be reduced according to Table 2. For the 2018, 2015 and 2012 IBC, the allowable loads or load combinations must not be adjusted.
- <sup>11</sup> Allowable loads must be the lesser of the adjusted masonry or bond values tabulated above and the steel values given in Table 10.
- <sup>12</sup> Tabulated allowable bond loads must be adjusted for increased base material temperatures in accordance with Figure 1, as applicable.
- <sup>13</sup> For combined loading, see Section 4.1.2.

**TABLE 4A—ALLOWABLE ADHESIVE BOND TENSION LOADS FOR HIS-N AND HIS-RN INSERTS IN THE FACE OF GROUT-FILLED CONCRETE MASONRY UNITS (POUNDS)**<sup>1,2,7,8,9,10,11,12, 13</sup>

Anchor Diameter (inches)	Embedment (inches) <sup>3</sup>	Load @ $c_{cr}$ and $s_{cr}$	Spacing <sup>4</sup>			Edge Distance <sup>5</sup>		
			Critical, $s_{cr}$ (inches)	Minimum, $s_{min}$ (inches)	Load Reduction Factor @ $s_{min}$ <sup>6</sup>	Critical, $c_{cr}$ (inches)	Minimum, $c_{min}$ (inches)	Load Reduction Factor @ $c_{min}$ <sup>6</sup>
3/8	4 1/4	2075	17	4	0.55	12	4	0.82
1/2	5	2710	20	4	0.55	20	4	0.63

**TABLE 4B—ALLOWABLE ADHESIVE BOND SHEAR LOADS FOR HIS-N AND HIS-RN INSERTS IN THE FACE OF GROUT-FILLED CONCRETE MASONRY UNITS (POUNDS)**<sup>1,2,7,8,9,10,11,12, 13</sup>

Anchor Diameter (inches)	Embedment (inches) <sup>3</sup>	Load @ $c_{cr}$ and $s_{cr}$	Spacing <sup>4</sup>			Edge Distance <sup>5</sup>			
			Critical, $s_{cr}$ (inches)	Minimum, $s_{min}$ (inches)	Load Reduction Factor @ $s_{min}$ <sup>6</sup>	Critical, $c_{cr}$ (inches)	Minimum, $c_{min}$ (inches)	Load Reduction Factor @ $c_{min}$ <sup>6</sup>	
								Load Perpendicular to Edge	Load Parallel to Edge
3/8	4 1/4	1100	17	4	0.74	12	4	0.72	1.00
1/2	5	2065	20	4	0.71	20	4	0.40	0.87

For SI: 1 inch = 25.4 mm, 1 lbf = 4.45 N, 1 psi = 6.89 kPa.

**The following footnotes apply to both Tables 4A and 4B:**

- <sup>1</sup> All values are for anchors installed in fully grouted concrete masonry walls with minimum masonry strength of 1500 psi. Concrete masonry units must be light-, medium-, or normal-weight conforming to ASTM C90. Allowable loads have been calculated using a safety factor of 5.
- <sup>2</sup> Anchors may be installed in any location in the face of the masonry wall (cell, web, joints). Anchors are limited to one per masonry cell.
- <sup>3</sup> Embedment depth is measured from the outside face of the concrete masonry unit.
- <sup>4</sup> The critical spacing,  $s_{cr}$ , is the anchor spacing where full load values in the table may be used. The minimum spacing,  $s_{min}$ , is the minimum anchor spacing for which values are available and installation is recommended. Spacing is measured from the center of one anchor to the center of an adjacent anchor.
- <sup>5</sup> The critical edge distance,  $c_{cr}$ , is the edge distance where full load values in the table may be used. The minimum edge distance,  $c_{min}$ , is the minimum edge distance for which values are available and installation is permitted. Edge distance is measured from the center of the anchor to the closest edge (See Figure 2).
- <sup>6</sup> Load reduction factors are multiplicative; both spacing and edge distance load reduction factors must be considered.
- <sup>7</sup> Load values for anchors installed at less than  $s_{cr}$  and  $c_{cr}$  must be multiplied by the appropriate load reduction factor based on actual edge distance (c) or spacing (s).
- <sup>8</sup> Linear interpolation of load values between minimum spacing ( $s_{min}$ ) and critical spacing ( $s_{cr}$ ) and between minimum edge distance ( $c_{min}$ ) and critical edge distance ( $c_{cr}$ ) is permitted.
- <sup>9</sup> Concrete masonry thickness must be equal to or greater than 1.5 times the anchor embedment depth.
- <sup>10</sup> Anchors are not recognized for resisting earthquake forces. When using the basic load combinations in accordance with IBC Section 1605.3.1, or the alternative basic load combinations in IBC Section 1605.3.2, tabulated allowable loads must not be increased for wind loading.
- <sup>11</sup> Allowable loads must be the lesser of the adjusted masonry or bond values tabulated above and the steel values given in Table 10.
- <sup>12</sup> Tabulated allowable bond loads must be adjusted for increased base material temperatures in accordance with Figure 1, as applicable.
- <sup>13</sup> For combined loading, see Section 4.1.2.

**TABLE 5A—ALLOWABLE ADHESIVE BOND TENSION AND SHEAR LOADS FOR THREADED RODS IN THE TOP OF GROUT-FILLED MASONRY UNITS (POUNDS)<sup>1,2,3,4,8</sup>**

Anchor Diameter (inches)	Embedment (inches)	Edge Distance <sup>5,6</sup> (inches)	Minimum End Distance (inches)	Spacing		Tension Load <sup>7</sup>		Shear Load <sup>7</sup>		
				Critical, $s_{cr}$ (inches)	Minimum, $s_{min}$ (inches)	@ $s_{cr}$	Reduction Factor @ $s_{min}$	Load Parallel to Edge of Masonry Wall	Load Perpendicular to Edge of Masonry Wall	Reduction Factor @ $s_{min}$
1/2	4 1/2	1 3/4	8	16	3	1,165	0.57	815	345	0.5
		4				1,625	0.50	1,445	505	0.5
5/8	5 5/8	1 3/4				1,165	0.58	1,190	385	0.5
		4				1,590	0.50	1,825	655	0.5
3/4	6 3/4	2 3/4				1,020	0.74	1,405	425	0.59

**TABLE 5B—ALLOWABLE ADHESIVE BOND TENSION AND SHEAR LOADS FOR REINFORCING BARS IN THE TOP OF GROUT-FILLED MASONRY UNITS (POUNDS)<sup>1,2,3,4,8</sup>**

Reinforcing Bar Size	Embedment (inches)	Edge Distance <sup>5,6</sup> (inches)	Minimum End Distance (inches)	Minimum, $s_{min}$ (inches)	Tension Load <sup>7</sup>	Shear Load <sup>7</sup>	
						Load Parallel to Edge of Masonry Wall	Load Perpendicular to Edge of Masonry Wall
No. 4	4 1/2	1 3/4	8	16	865	635	245
No. 5	5 5/8	1 3/4			980	755	295

For SI: 1 inch = 25.4 mm, 1 lbf = 4.45 N, 1 psi = 6.89 kPa.

**The following footnotes apply to both Tables 5A and 5B:**

- <sup>1</sup> All values are for anchors installed in fully grouted concrete masonry with minimum masonry strength of 1500 psi. Concrete masonry units must be light-, medium-, or normal-weight conforming to ASTM C90. Allowable loads have been calculated using a safety factor of 5.
- <sup>2</sup> When using the basic load combinations in accordance with IBC Section 1605.3.1, tabulated allowable loads must not be increased for seismic or wind loading. When using the alternative basic load combinations in the 2009 IBC Section 1605.3.2 that include seismic or wind loads, tabulated allowable loads may be increased, or the alternative basic load combinations may be reduced according to Table 2. For the 2018, 2015 and 2012 IBC, the allowable loads or load combinations must not be adjusted.
- <sup>3</sup> One anchor must be permitted to be installed in each cell of the CMU block. Refer to Figure 3 for an illustration of the anchor location for which the tabulated values are applicable.
- <sup>4</sup> The tabulated edge distance is measured from the anchor centerline to the edge of the CMU block as depicted in Figure 3.
- <sup>5</sup> Anchors must be installed into the grouted cell. Anchors are not permitted to be installed in a head joint, flange or web of the concrete masonry unit.
- <sup>6</sup> Linear interpolation of load values between the two tabulated edge distances is permitted, as applicable.
- <sup>7</sup> Allowable loads must be the lesser of the adjusted masonry or bond values tabulated above and the steel values given in Tables 10 and 11.
- <sup>8</sup> Tabulated allowable bond loads must be adjusted for increased base material temperatures in accordance with Figure 1, as applicable.

**TABLE 5C—ALLOWABLE ADHESIVE BOND TENSION AND SHEAR LOADS FOR THREADED RODS IN THE SIDE OF GROUT-FILLED MASONRY UNITS (POUNDS)<sup>1,2,3,4,7</sup>**

Anchor Diameter	Embedment (inches)	Edge Distance <sup>5</sup> (inches)	Minimum End Distance (inches)	Tension Load <sup>6</sup>	Shear Load <sup>6</sup>	
					Load Parallel to Edge of Masonry Wall	Load Perpendicular to Edge of Masonry Wall
1/2	4 1/2	1 3/4	8	990	885	255
5/8	5 5/8	1 3/4		1,200	1,220	330
3/4	5 5/8	2 3/4		1,200	1,770	530

**TABLE 5D—ALLOWABLE ADHESIVE BOND TENSION AND SHEAR LOADS FOR REINFORCING BARS IN THE SIDE OF GROUT-FILLED MASONRY UNITS (POUNDS)<sup>1,2,3,4,7</sup>**

Reinforcing Bar Size	Embedment (inches)	Edge Distance <sup>5</sup> (inches)	Minimum End Distance (inches)	Tension Load <sup>6</sup>	Shear Load <sup>6</sup>	
					Load Parallel to Edge of Masonry Wall	Load Perpendicular to Edge of Masonry Wall
No. 4	4 1/2	1 3/4	8	1,055	835	255
No. 5	5 5/8	1 3/4		1,160	990	275

For SI: 1 inch = 25.4 mm, 1 lbf = 4.45 N, 1 psi = 6.89 kPa.

**The following footnotes apply to both Tables 5C and 5D:**

- <sup>1</sup> All values are for anchors installed in fully grouted concrete masonry with minimum masonry strength of 1500 psi. Concrete masonry units must be light-, medium-, or normal-weight conforming to ASTM C90. Allowable loads have been calculated using a safety factor of 5.
- <sup>2</sup> When using the basic load combinations in accordance with IBC Section 1605.3.1, tabulated allowable loads must not be increased for seismic or wind loading. When using the alternative basic load combinations in the 2009 IBC Section 1605.3.2 that include seismic or wind loads, tabulated allowable loads may be increased, or the alternative basic load combinations may be reduced according to Table 2. For the 2018, 2015 and 2012 IBC, the allowable loads or load combinations must not be adjusted.
- <sup>3</sup> Refer to Figure 4 for an illustration of the anchor location for which the tabulated values are applicable.
- <sup>4</sup> The tabulated edge distance is measured from the anchor centerline to the edge of the CMU block as depicted in Figure 4.
- <sup>5</sup> Anchors must be installed into the grouted cell. Anchors are not permitted to be installed in a flange, or bed joint of the concrete masonry unit.
- <sup>6</sup> Allowable loads must be the lesser of the adjusted masonry or bond values tabulated above and the steel values given in Tables 10 and 11.
- <sup>7</sup> Tabulated allowable bond loads must be adjusted for increased base material temperatures in accordance with Figure 1, as applicable.

**TABLE 6—ALLOWABLE ADHESIVE BOND TENSION AND SHEAR LOADS FOR THREADED RODS IN THE FACE OF HOLLOW CONCRETE MASONRY UNITS (POUNDS)<sup>1,3,7,9</sup>**

Anchor Diameter (inches)	Embedment (inches) <sup>2</sup>	Tension Load		Critical and Minimum Edge Distance for Tension, $c_{cr}$ and $c_{min}$ (inches)	Shear Load at $c_{cr}$		Edge Distances for Shear <sup>6</sup>		
		Installation in the Cell <sup>4, 5, 8</sup>	Installation in Bed Joint <sup>5, 8</sup>		Installation in the Cell <sup>4,5,8</sup>	Installation in Bed Joint <sup>5,8</sup>	Critical, $c_{cr}$ (inches)	Minimum, $c_{min}$ (inches)	Load Reduction Factor
1/4	2	220	300	4	355	385	4	4	1.00
5/16	2	390	300	4	630	435	12	4	0.73
3/8	2	390	300	4	645	550	12	4	0.73
1/2	2	390	300	4	670	755	12	4	0.73

**TABLE 7—ALLOWABLE ADHESIVE BOND TENSION AND SHEAR LOADS FOR HIT-IC INSERTS IN THE FACE OF HOLLOW CONCRETE MASONRY UNITS (POUNDS)<sup>1,3,7,9</sup>**

Anchor Diameter (inches)	Embedment (inches) <sup>2</sup>	Tension Load <sup>4,5,8</sup>	Critical and Minimum Edge Distance for Tension, $c_{cr}$ and $c_{min}$ (inches)	Shear Load at $c_{cr}$ <sup>4,5,8</sup>	Edge Distances for Shear <sup>6</sup>		
					Critical, $c_{cr}$ (inches)	Minimum, $c_{min}$ (inches)	Load Reduction Factor
5/16	2	415	4	605	12	4	0.80
3/8	2	480 <sup>5</sup>	4	620	12	4	0.78
1/2	2	495 <sup>5</sup>	4	620	12	4	0.75

For SI: 1 inch = 25.4 mm, 1 lbf = 4.45 N, 1 psi = 6.89 kPa.

**The following footnotes apply to both Tables 6 and 7:**

- <sup>1</sup> All values are for anchors installed in hollow concrete masonry with minimum masonry strength of 1500 psi. Concrete masonry units must be light-, medium-, normal-weight conforming to ASTM C90. Allowable loads have been calculated using a safety factor of 5.
- <sup>2</sup> Tabulated embedment depth is limited by the length of the plastic HIT-SC screens.
- <sup>3</sup> Anchors must be installed in the face of the hollow CMU masonry wall. A maximum of two anchors may be installed in a single cell of the hollow CMU block.
- <sup>4</sup> Tabulated values are for one anchor installed in the cell of the hollow CMU. Installation in other locations of the hollow CMU (mortar joints, flange, or cell web) is not permitted.
- <sup>5</sup> The minimum spacing,  $s_{min}$ , for which values are available and installation is permitted is 4 inches. Two anchors installed in adjacent cells may be spaced as close as 4 inches apart with no reduction in tension or shear capacity. Two anchors installed in the same cell can be spaced as close as 4 inches apart with no reduction in shear capacity. For two anchors installed in the same cell spaced as close as 4 inches apart, the 3/8-inch and 1/2-inch diameter HIT-IC inserts require a 20% reduction in the tension capacity, and the 5/16-inch diameter HIT-IC insert requires no reduction in tension capacity.
- <sup>6</sup> The critical edge distance,  $c_{cr}$ , is the edge distance where full load values in the table may be used. The minimum edge distance,  $c_{min}$ , is the minimum edge distance for which values are available and installation is permitted. Edge distance is measured from the center of the anchor to the closest edge.
- <sup>7</sup> Anchors are not recognized for resisting earthquake forces. When using the basic load combinations in accordance with IBC Section 1605.3.1, or the alternative basic load combinations in IBC Section 1605.3.2, tabulated allowable loads must not be increased for wind loading.
- <sup>8</sup> Allowable loads must be the lesser of the adjusted masonry or bond values tabulated above and the steel values given in Table 10.
- <sup>9</sup> Tabulated allowable bond loads must be adjusted for increased base material temperatures in accordance with Figure 1, as applicable.

**TABLE 8A—ALLOWABLE ADHESIVE BOND TENSION LOADS FOR THREADED RODS IN THE FACE OF HOLLOW BRICK MASONRY (POUNDS)<sup>1,3,4,8,9,10</sup>**

Anchor Diameter (inches)	Embedment (inches) <sup>2</sup>	Load @ $c_{cr}$ and $s_{cr}$ <sup>8</sup>	Spacing <sup>5</sup>			Edge Distance <sup>6</sup>		
			Critical, $s_{cr}$ (inches)	Minimum, $s_{min}$ (inches)	Load Reduction Factor at $s_{min}$ <sup>7</sup>	Critical, $c_{cr}$ (inches)	Minimum, $c_{min}$ (inches)	Load Reduction Factor at $c_{min}$ <sup>7</sup>
1/4	3 1/8	530	8	4	0.88	6 3/8	4	0.93
5/16	3 1/8	735	8	4	0.82	6 3/8	4	0.80
3/8	3 1/8	905	8	4	0.54	6 3/8	4	0.83
1/2	3 1/8	905	8	4	0.50	6 3/8	4	1.0

**TABLE 8B—ALLOWABLE ADHESIVE BOND SHEAR LOADS FOR THREADED RODS IN THE FACE OF HOLLOW BRICK MASONRY (POUNDS)<sup>1,3,4,8,9,10</sup>**

Anchor Diameter (inches)	Embedment (inches) <sup>2</sup>	Load @ $c_{cr}$ and $s_{cr}$ <sup>8</sup>	Spacing <sup>5</sup>			Edge Distance <sup>6</sup>		
			Critical, $s_{cr}$ (inches)	Minimum, $s_{min}$ (inches)	Load Reduction Factor at $s_{min}$ <sup>7</sup>	Critical, $c_{cr}$ (inches)	Minimum, $c_{min}$ (inches)	Load Reduction Factor at $c_{min}$ <sup>7</sup>
1/4	3 1/8	370	8	4	0.84	8	4	0.86
5/16	3 1/8	595	8	4	0.81	8	4	0.93
3/8	3 1/8	1045	8	4	0.59	12	4	0.54
1/2	3 1/8	1685	8	4	0.50	12	4	0.36

For SI: 1 inch = 25.4 mm, 1 lbf = 4.45 N, 1 psi = 6.89 kPa.

(The following footnotes apply to both Tables 8A and 8B)

- <sup>1</sup> All values are for anchors installed in hollow brick masonry with minimum masonry strength of 3000 psi. Hollow brick units must be in conformance with ASTM C652. Allowable loads have been calculated using a safety factor of 5.
- <sup>2</sup> Tabulated embedment depth is limited by the length of the plastic HIT-SC screens.
- <sup>3</sup> Anchors must be installed in the face of the hollow brick masonry wall.
- <sup>4</sup> Tabulated values are for the anchor installed in the center of the hollow brick, mortar joints, flanges, or cell web (all wall face locations permitted).
- <sup>5</sup> The critical spacing,  $s_{cr}$ , is the anchor spacing where full load values in the table may be used. The minimum spacing,  $s_{min}$ , is the minimum anchor spacing for which values are available and installation is recommended. Spacing is measured from the center of one anchor to the center of an adjacent anchor.
- <sup>6</sup> The critical edge distance,  $c_{cr}$ , is the edge distance where full load values in the table may be used. The minimum edge distance,  $c_{min}$ , is the minimum edge distance for which values are available and installation is permitted. Edge distance is measured from the center of the anchor to the closest edge.
- <sup>7</sup> Load values for anchors installed at less than  $s_{cr}$  and  $c_{cr}$  must be multiplied by the appropriate load reduction factor based on actual edge distance (c) or spacing (s).
- <sup>8</sup> Anchors are not recognized for resisting earthquake forces. When using the basic load combinations in accordance with IBC Section 1605.3.1, or the alternative basic load combinations in IBC Section 1605.3.2, tabulated allowable loads must not be increased for wind loading.
- <sup>9</sup> Allowable loads must be the lesser of the adjusted masonry or bond values tabulated above and the steel values given in Table 10.
- <sup>10</sup> Tabulated allowable bond loads must be adjusted for increased base material temperatures in accordance with Figure 1, as applicable.

**TABLE 9—ALLOWABLE ADHESIVE BOND TENSION AND SHEAR LOADS FOR HIT-IC INSERTS IN THE FACE OF HOLLOW BRICK MASONRY (POUNDS)<sup>1,3,4,7,9</sup>**

Anchor Diameter (inches)	Embedment (inches) <sup>2</sup>	Tension Load <sup>5,8</sup>	Critical and Minimum Edge Distance for Tension, $c_{cr}$ and $c_{min}$ (inches)	Shear Load @ $c_{cr}$ <sup>5,8</sup>	Edge Distance for Shear <sup>6</sup>		
					Critical, $c_{cr}$ (inches)	Minimum, $c_{min}$ (inches)	Load Reduction Factor
5/16	3 1/8	880	6 3/8	655	8	8	1.00
3/8	3 1/8	880	6 3/8	1235	12	8	0.66
1/2	3 1/8	990	6 3/8	1895	12	8	0.44

For SI: 1 inch = 25.4 mm, 1 lbf = 4.45 N, 1 psi = 6.89 kPa.

- <sup>1</sup> All values are for anchors installed in hollow brick masonry with minimum masonry strength of 3000 psi. Hollow brick units must be in conformance with ASTM C652. Allowable loads have been calculated using a safety factor of 5.
- <sup>2</sup> Tabulated embedment depth is limited by the length of the plastic HIT-SC screens.
- <sup>3</sup> Anchors must be installed in the face of the hollow brick masonry wall.
- <sup>4</sup> Tabulated values are for one anchor installed in the center of the hollow brick, mortar joints, flanges, or cell web (all wall face locations permitted).
- <sup>5</sup> One anchor must be permitted to be installed in each brick. Two anchors installed in adjacent bricks may be spaced as close as 8 inches apart with no load reduction.
- <sup>6</sup> The critical edge distance,  $c_{cr}$ , is the edge distance where full load values in the table may be used. The minimum edge distance,  $c_{min}$ , is the minimum edge distance for which values are available and installation is permitted. Edge distance is measured from the center of the anchor to the closest edge.
- <sup>7</sup> Anchors are not recognized for resisting earthquake forces. When using the basic load combinations in accordance with IBC Section 1605.3.1, or the alternative basic load combinations in IBC Section 1605.3.2, tabulated allowable loads must not be increased for wind loading.
- <sup>8</sup> Allowable loads must be the lesser of the adjusted masonry or bond values tabulated above and the steel values given in Table 10.
- <sup>9</sup> Tabulated allowable bond loads must be adjusted for increased base material temperatures in accordance with Figure 1, as applicable.

**TABLE 10—ALLOWABLE TENSION AND SHEAR LOADS BASED ON STEEL STRENGTH FOR THREADED RODS (pounds)<sup>1,2,3</sup>**

Anchor Diameter (inches)	Tension					Shear				
	ISO 898 Class 5.8	ASTM A36	ASTM A307	ASTM A193 B7	ASTM F593 CW (316/304)	ISO 898 Class 5.8	ASTM A36	ASTM A307	ASTM A193 B7	ASTM F593 CW (316/304)
1/4	1,175	940	970	2,025	1,620	605	485	500	1,040	835
5/16	1,835	1,470	1,520	3,160	2,530	945	755	780	1,630	1,300
3/8	2,640	2,115	2,185	4,555	3,645	1,360	1,090	1,125	2,345	1,875
1/2	4,700	3,755	3,885	8,100	6,480	2,420	1,935	2,000	4,170	3,335
5/8	7,340	5,870	6,075	12,655	10,125	3,780	3,025	3,130	6,520	5,215
3/4	10,570	8,455	8,750	18,225	12,390	5,445	4,355	4,505	9,390	6,385

**TABLE 11—ALLOWABLE TENSION AND SHEAR LOADS BASED ON STEEL STRENGTH FOR REINFORCING BARS (pounds)<sup>1,2,3</sup>**

Rebar Size	Tension	Shear
	ASTM A615, Grade 60	ASTM A615, Grade 60
No. 3	3,270	1,685
No. 4	5,940	3,060
No. 5	9,205	4,745
No. 6	13,070	6,730

**(The following footnotes apply to both Tables 10 and 11)**

<sup>1</sup> Allowable load used in the design must be the lesser of bond values and tabulated steel values

<sup>2</sup> Allowable tension and shear loads for threaded rods to resist short term loads, such as wind or seismic, must be calculated in accordance with Section 4.1 as applicable.

<sup>3</sup> Allowable steel loads are based on allowable tension and shear stresses equal to 0.33 x F<sub>u</sub> and 0.17 x F<sub>u</sub>, respectively.

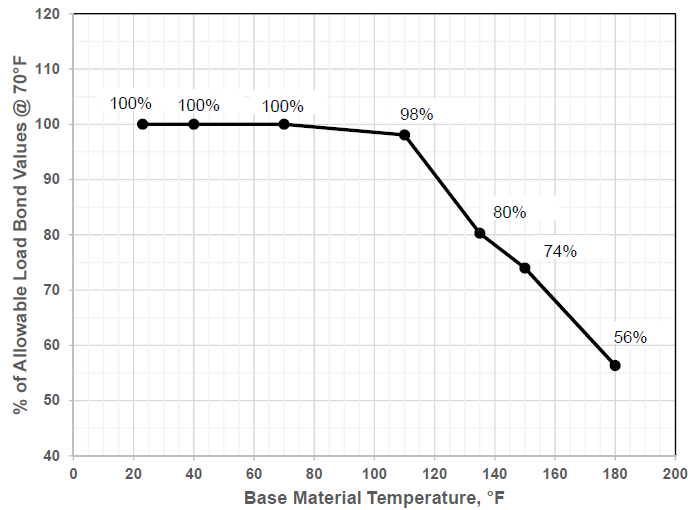

**FIGURE 1—INFLUENCE OF BASE MATERIAL TEMPERATURE ON ALLOWABLE TENSION AND SHEAR LOADS FOR HILTI HIT-HY 270 ADHESIVE**

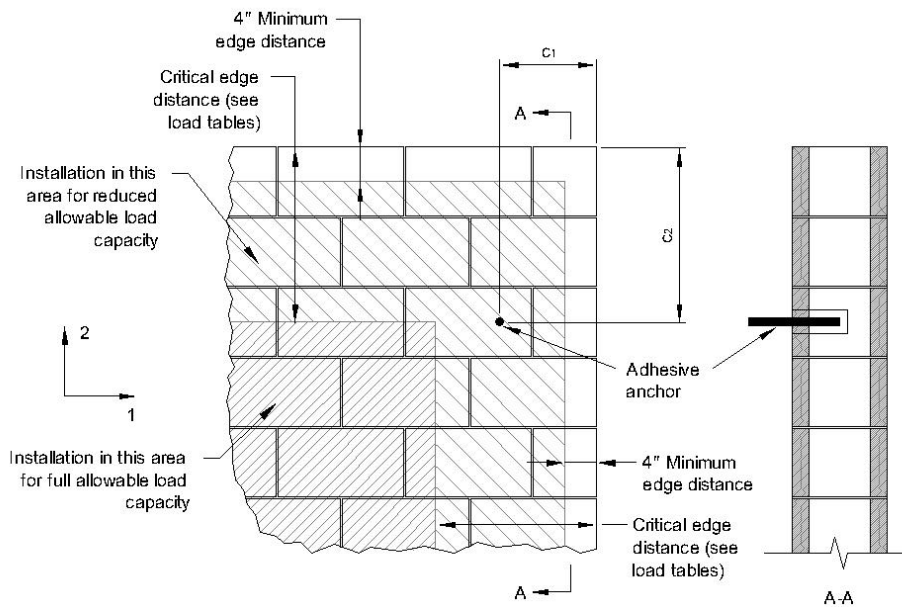

**FIGURE 2—ALLOWABLE ANCHOR INSTALLATION LOCATIONS IN THE FACE OF GROUT-FILLED CONCRETE MASONRY (ASTM C90)**

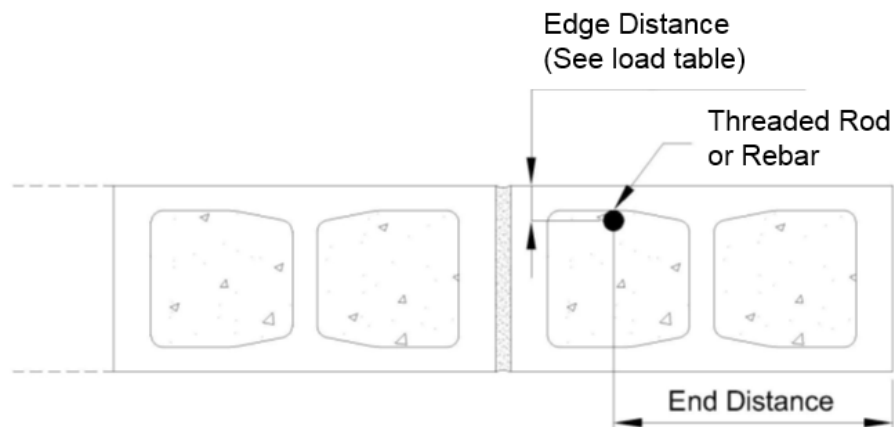

**FIGURE 3—EDGE AND END DISTANCES FOR THREADED RODS INSTALLED IN THE TOP OF GROUT-FILLED CONCRETE MASONRY**

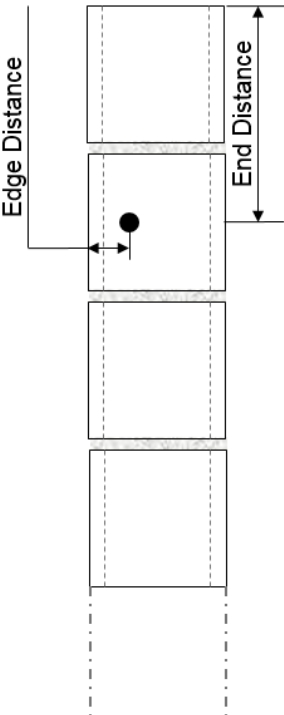

FIGURE 4—EDGE AND END DISTANCES FOR THREADED RODS INSTALLED IN THE SIDE OF GROUT-FILLED CONCRETE MASONRY



**Hilti HIT-HY 270**  
Instruction for use en





**Danger** (A, B) (A) (B)

**Contains:** melhacrylates, dibenzoyl peroxide, boric acid





- Causes skin irritation.(A)
- May cause an allergic skin reaction.(A,B)
- Causes serious eye irritation.(A)
- May damage fertility or the unborn child.(A)
- Very toxic to aquatic life.(B)
- Harmful to aquatic life with long lasting effects.(A)



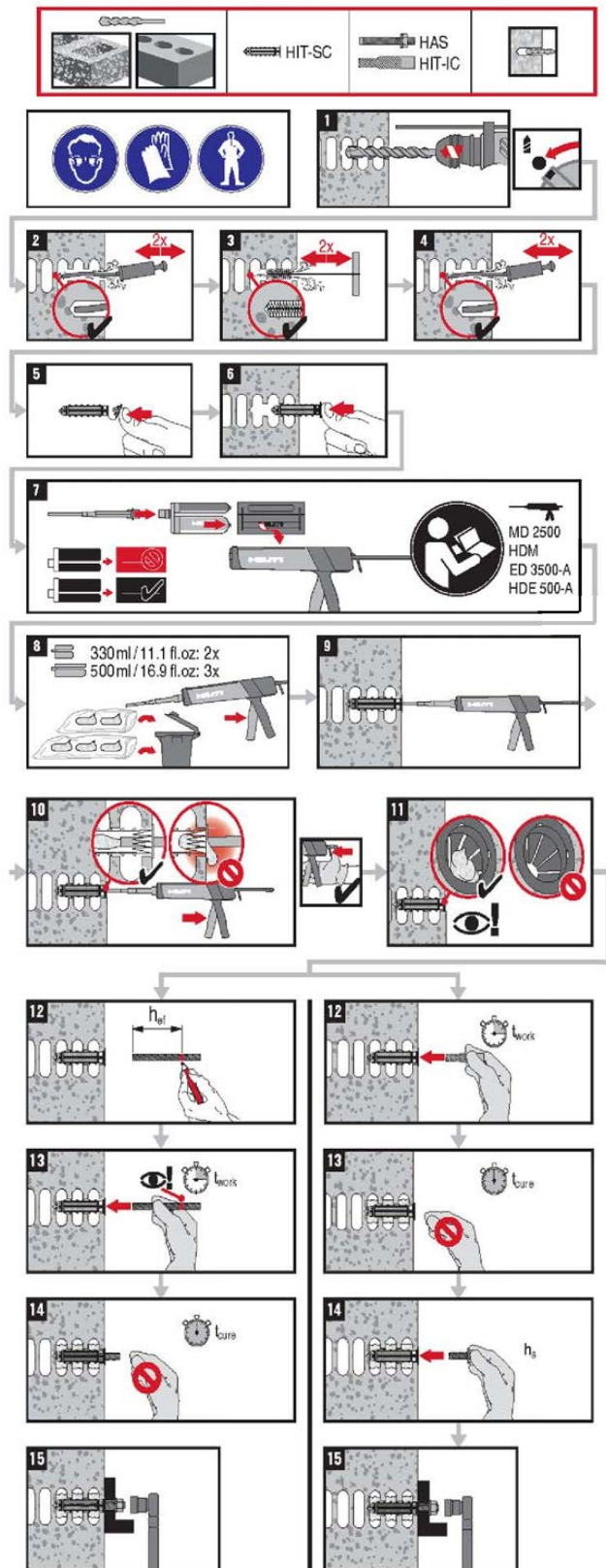

**ICC ESR - 4143**



[F]	[°C]				
23-32	-5...0	10 min	$t_{work}$	6 h	
33-41	1...5	10 min		4 h	
42-50	6...10	7 min		2.5 h	
51-68	11...20	4 min		1.5 h	
69-86	21...30	2 min		30 min	
87-104	31...40	1 min		20 min	





[F]	[°C]				
41	5	10 min	$t_{work}$	4 h	
42-50	6...10	7 min		2.5 h	
51-68	11...20	4 min		1.5 h	
69-86	21...30	2 min		30 min	
87-104	31...40	1 min		20 min	

FIGURE 5—MANUFACTURERS PRINTED INSTALLATION INSTRUCTIONS



**Adhesive anchoring system for rebar and anchor fastenings.**

For use in hollow and solid masonry of clay brick, concrete block and multi wythe wall.

**Hilti HIT-HY 270**  
 Contains: methacrylates, dibenzoyl peroxide, boric acid

**Danger**

H315	Causes skin irritation.(A)
H317	May cause an allergic skin reaction.(A,B)
H319	Causes serious eye irritation.(A)
H360	May damage fertility or the unborn child.(A)
H400	Very toxic to aquatic life (B)
H412	Harmful to aquatic life with long lasting effects.(A)

P202 Do not get in eyes, on skin, or on clothing.  
 P280 Wear protective gloves/protective clothing/eye protection/face protection.  
 P302+P352 IF ON SKIN: Wash with plenty of soap and water.  
 P305+P351+P338 IF IN EYES: Rinse cautiously with water for several minutes. Remove contact lenses, if present and easy to do. Continue rinsing.  
 P333+P313 If skin irritation or rash occurs: Get medical advice/attention.  
 P337+P313 If eye irritation persists: Get medical advice/attention.

**Disposal considerations**

**Empty packs:**  
 ▶ Leave the mixer attached and dispose of via the local Green Dot recovery system or EAK waste material code: 150102 plastic packaging

**Full or partially emptied packs:**

▶ Must be disposed of as special waste in accordance with official regulations.  
 EAK waste material code: 08 04 00\* waste adhesives and sealants containing organic solvents or other dangerous substances, or EAK waste material code: 20 01 27\* paint, inks, adhesives and resins containing dangerous substances.

**Warranty:** Refer to standard Hilti terms and conditions of sale for warranty information.

Failure to observe these installation instructions, use of non-Hilti anchors, poor or questionable base material conditions, or unique applications may affect the reliability or performance of the fastenings.

**Product Information**

- Always keep these instructions together with the product even when given to other persons.
- Check expiration date: See imprint on foil pack manifold (month/year). Do not use expired product.
- Foil pack temperature during usage: between 41 °F and 104 °F / +5 °C and 40 °C.
- Base material temperature at time of installation: between 23 °F and 104 °F / -5 °C and 40 °C.
- **Exception in hollow, solid and multi-wythe solid clay brick:** between 41 °F and 104 °F / +5 °C and 40 °C.
- Conditions for transport and storage: Keep in a cool, dry and dark place between 41 °F and 77 °F / 5 °C and 25 °C.
- For any application not covered by this document / beyond values specified, please contact Hilti.
- Partly used foil packs must remain in the cassette and has to be used within 4 weeks. Leave the mixer attached on the foil pack manifold and store within the cassette under the recommended storage conditions. If reused, attach a new mixer and discard the initial quantity of anchor adhesive.

**NOTICE**

- ▲ **Improper handling may cause mortar splashes.**
  - Always wear safety glasses, gloves and protective clothes during installation.
  - Never start dispensing without a mixer properly screwed on.
  - Attach a new mixer prior to dispensing a new foil pack (ensure snug fit).
  - Use only the type of mixer (HIT-RE-M) supplied with the adhesive. Do not modify the mixer in any way.
  - Never use damaged foil packs and/or damaged or unclean foil pack holders (cassettes).
- ▲ **Poor load values / potential failure of fastening points due to inadequate borehole cleaning.**
  - The boreholes must be free of debris, dust, water, ice, oil, grease and other contaminants prior to adhesive injection.
  - For blowing out the borehole – blow out with oil free air until return air stream is free of noticeable dust.
  - For brushing the borehole – only use specified wire brush. The brush must resist insertion into the borehole – if not the brush is too small and must be replaced.
- ▲ **Borehole filling in solid masonry:** Ensure that boreholes are filled from the back of the borehole without forming air voids. If necessary use the accessories / extensions to reach the back of the borehole.
- ▲ **Borehole filling in hollow masonry:** Use a mesh sleeve. Fill the mesh sleeve with mortar from the centering cap until mortar escapes at the centering cap (filling control).
- ▲ **Multi-Wythe Solid Brick application: HIT-SC sieve sleeves / sleeve sleeve combinations have to be filled outside the bore hole:** Push the mixer to the bottom of the last mesh sleeve (use mixer extension if necessary). Inject the anchor adhesive starting at the bottom of the last mesh sleeve while slowly withdrawing the mixing nozzle towards the centering cap, step by step, after each pull of the trigger. HIT-SC sieve sleeves have to be filled completely without forming air voids until anchor adhesive escapes at the centering cap (filling control).
- ▲ **Not adhering to these setting instructions can result in failure of fastening points!**

FIGURE 5—MANUFACTURERS PRINTED INSTALLATION INSTRUCTIONS (CONTINUED)

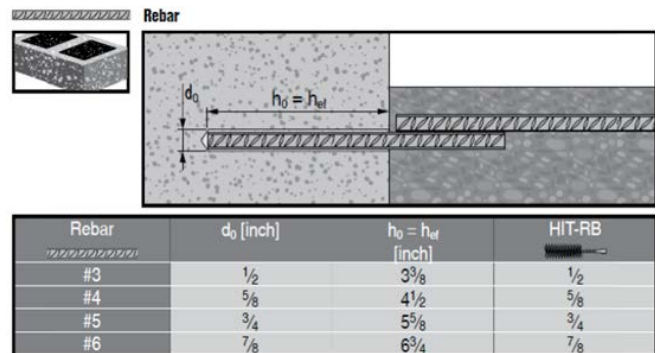
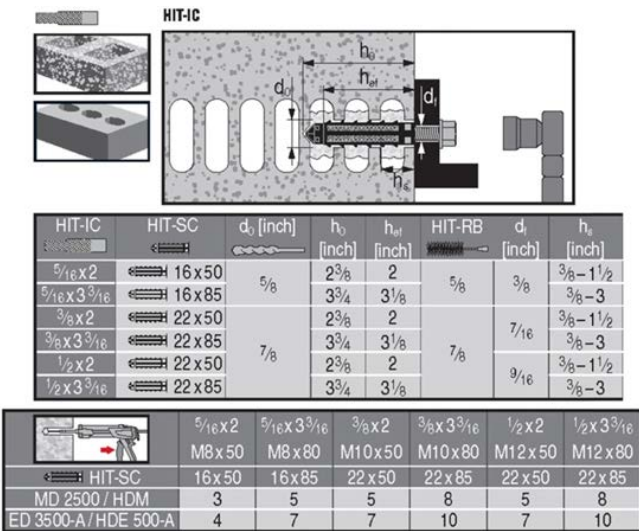
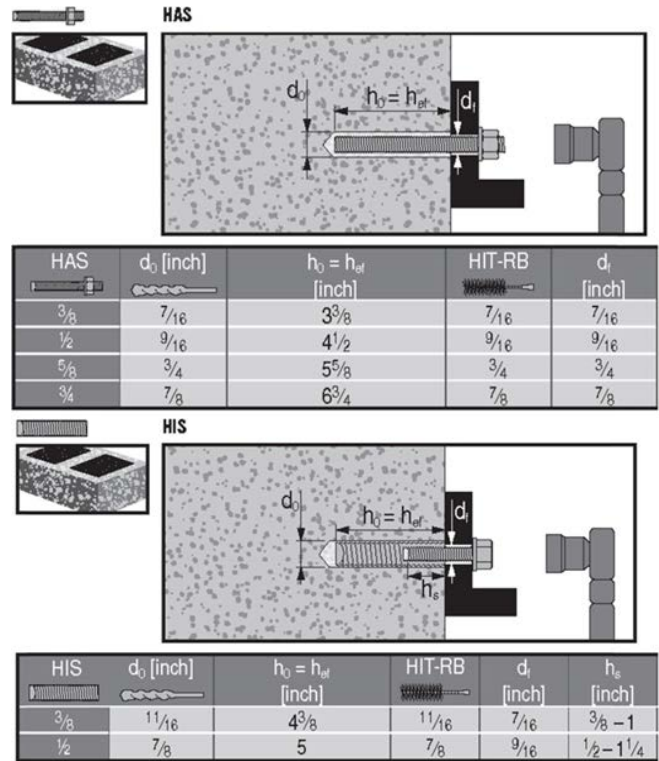
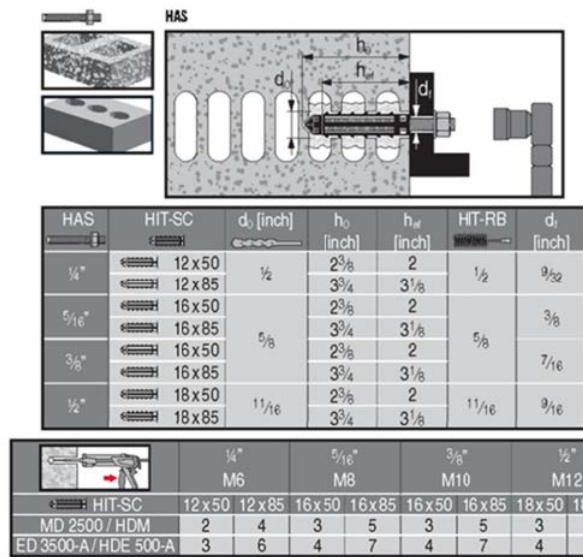

FIGURE 5—MANUFACTURERS PRINTED INSTALLATION INSTRUCTIONS (CONTINUED)

**DIVISION: 04 00 00—MASONRY**  
**Section: 04 05 19.16—Masonry Anchors**

**REPORT HOLDER:**

HILTI, INC.

**EVALUATION SUBJECT:**

HILTI HIT-HY 270 ADHESIVE ANCHOR SYSTEM

**1.0 REPORT PURPOSE AND SCOPE****Purpose:**

The purpose of this evaluation report supplement is to indicate that the Hilti HIT-HY 270 Adhesive Anchor System, described in ICC-ES evaluation report [ESR-4143](#), has also been evaluated for compliance with the codes noted below as adopted by the Los Angeles Department of Building and Safety (LADBS).

**Applicable code editions:**

- 2020 *City of Los Angeles Building Code* (LABC)
- 2020 *City of Los Angeles Residential Code* (LARC)

**2.0 CONCLUSIONS**

The Hilti HIT-HY 270 Adhesive Anchor System, described in Sections 2.0 through 7.0 of the evaluation report [ESR-4143](#), complies with the LABC Chapter 21, and the LARC, and is subject to the conditions of use described in this supplement.

**3.0 CONDITIONS OF USE**

The Hilti HIT-HY 270 Adhesive Anchor System described in this evaluation report supplement must comply with all of the following conditions:

- All applicable sections in the evaluation report [ESR-4143](#).
- The design, installation, conditions of use and identification of the anchors are in accordance with the 2018 *International Building Code*® (2018 IBC) provisions noted in the evaluation report [ESR-4143](#).
- The design, installation and inspection are in accordance with additional requirements of LABC Chapters 16 and 17, as applicable.
- Under the LARC, an engineered design in accordance with LARC Section R301.1.3 must be submitted.
- The allowable load values listed in the evaluation report and tables are for the connection of the adhesive anchors to the masonry. The connection between the adhesive anchors and the connected members shall be checked for capacity (which may govern).
- For use in wall anchorage assemblies to flexible diaphragm applications, anchors shall be designed per the requirements of City of Los Angeles Information Bulletin P/BC 2020-071.

This supplement expires concurrently with the evaluation report, reissued January 2022.

**DIVISION: 04 00 00—MASONRY**  
**Section: 04 05 19.16—Masonry Anchors**

**REPORT HOLDER:**

HILTI, INC.

**EVALUATION SUBJECT:**

HILTI HIT-HY 270 ADHESIVE ANCHOR SYSTEM

**1.0 REPORT PURPOSE AND SCOPE****Purpose:**

The purpose of this evaluation report supplement is to indicate that the Hilti HIT-HY 270 Adhesive Anchor System, described in ICC-ES evaluation report ESR-4143, has also been evaluated for compliance with the codes noted below.

**Applicable code editions:**

- 2020 *Florida Building Code—Building*
- 2020 *Florida Building Code—Residential*

**2.0 CONCLUSIONS**

The Hilti HIT-HY 270 Adhesive Anchor System, described in Sections 2.0 through 7.0 of ICC-ES evaluation report ESR-4143, complies with the *Florida Building Code—Building* and the *Florida Building Code—Residential*, provided the design requirements are determined in accordance with the *Florida Building Code—Building* or the *Florida Building Code—Residential*, as applicable. The installation requirements noted in ICC-ES evaluation report ESR-4143 for the 2018 *International Building Code*® meet the requirements of the *Florida Building Code—Building* or the *Florida Building Code—Residential*, as applicable.

Use of the Hilti HIT-HY 270 Adhesive Anchor System has also been found to be in compliance with the High-Velocity Hurricane Zone provisions of the *Florida Building Code—Building* and the *Florida Building Code—Residential*, with the following conditions:

- a) Design and installation must meet the requirements of Section 2122.7 of the *Florida Building Code—Building*.
- b) For anchorage of wood members, the connections subject to uplift must be designed for no less than 700 pounds (3114 N).

For products falling under Florida Rule 61G20-3, verification that the report holder's quality assurance program is audited by a quality assurance entity approved by the Florida Building Commission for the type of inspections being conducted is the responsibility of an approved validation entity (or the code official, when the report holder does not possess an approval by the Commission).

This supplement expires concurrently with the evaluation report, reissued January 2022.