

Firestop cable coating CP 678

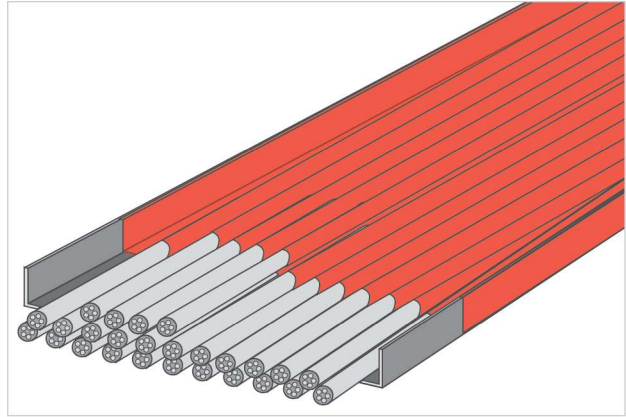

Product description

Hilti CP 678 is a ready to use, water based, intumescent cable coating, which can be applied by brush or airless spray to prevent the propagation of fires along internal electrical cables. Cables coated with CP 678 will exhibit increased protection in the event of a fire. Also suitable for protecting against spread of flame on timber panels.

Main applications

- Power plants.
- Telecommunication complexes.
- Industrial plants.
- Petrochemical plants.
- Paper mills.
- Factories and production facilities.

Product features

- Water soluble, odourless and solvent free.
- Rapid drying.
- Remains flexible when dry.
- Intumescent.
- Free of fibres, or as asbestos.
- No derating effect on cables.
- Compatible with the sheathing of electrical cables.



| Technical data | CP 678 |
|--|--|
| Density | ~1.3 g/cm ³ |
| Color | White |
| Chemical basis | Vinyl Acetate |
| Application Temperature Range | 5°C - 40°C |
| Approx. curing time ²⁾ | 24 h |
| pH Value | 7-8 |
| Building material class | B2 |
| Intumescent. | Yes |
| Shelf life (@73°F/23°C and 50% relative humidity) | 18 months |
| LEED VOC | 60 g/l |
| Temperature resistance of cured coating | 30°C to 80°C |
| Application of second layer | After 2 to 4 hours |
| Consistency | can be applied by paint brush or sprayed |
| electric surface resistance per DIN VDE 0472/05.85 | 1,1 x 10 ⁹ Ω |
| Transport Temperature: | +5°C to +25°C |
| Viscosity: | approx. 50.000 mPas |

¹⁾ at 77°F/25°C and 50% relative humidity; from date of manufacture

²⁾ at 75°F/24°C, 50% relative humidity

Internationally Tested and approved



IEC-60332

| Ordering designation | Package contents | Sales pack quantity | Item number |
|----------------------|---------------------------------------|---------------------|-------------|
| CP 678 20KG | 1x Firestop cable coating CP 678 kpl. | 1 pc | 334892 |

Consumption of CP 678 cable coating depends upon the application for which it is being used. The following application rates apply for the different standards:

| Test Standard | Dry film thickness | Wet film thickness | Aprox. Requirement |
|---|--------------------|--------------------|---|
| IEC 60 332 -3 | 1.0 mm coating | 1.4 mm coating | 1.8 kg/m ² (1.4 liters/m ²) |
| Germanischer Lloyd (based on IEC 60332 -3) | 0.5 mm coating | 0.7 mm coating | 0.9 kg/m ² (0.7 liters/m ²) |
| Factory Mutual Approval | 1.6 mm | 2.2 mm | 2.86 kg/m ² (2.2 liters/m ²) |

* Each 20 kilogram container of CP 678 contains approximately 15.4 liters.

Installation instructions for CP 678

Opening

- Clean the cables. The cables and cable supporting structures must be dry and free from dust, grease or oil and installed in compliance with local building and electrical standards.
- Prepare the cable coating. Thoroughly mix the CP 678 coating. Any separated water in the container must also be mixed in. Do not add water.
- Apply CP 678 cable coating to all areas of the cables and cable run over the required length. This can be done using a paint brush, roller or airless spray gun with the recommended 0.029" nozzle and 40° spray angle.

- Each application will achieve a dry film thickness of approx. 0.5 mm. To meet IEC 332 requirements, the dry film thickness must be at least 0.5 mm. For Factory Mutual requirements the dry film thickness must reach 1.6 mm.

Coverage

- On a flat surface coverage will be approximately 650 gm per m² (at 0.5 mm DFT) .
- On cable bundles and cable trays allow 1 to 1.5 kg per m² (at 0.5 mm DFT) depending on volume of cables, method of application and wastage (ie. over spray).

Do not

- Paint over the coating.
- Use outside or in damp rooms.
- Apply to uninsulated cables.

Safety precautions

- Keep out of the reach of children.
- Observe the safety data sheet.
- Wear suitable gloves and eye protection.

Storage

- Store only in the original packaging in a location protected from moisture.
- Observe expiry date on bucket.
- Store at temperatures between 5°C and 37°C.

