

UL Product iQ™



BXUV.Y634 - FIRE-RESISTANCE RATINGS - ANSI/UL 263

Design/System/Construction/Assembly Usage Disclaimer

- Authorities Having Jurisdiction should be consulted in all cases as to the particular requirements covering the installation and use of UL Certified products, equipment, system, devices, and materials.
- Authorities Having Jurisdiction should be consulted before construction.
- Fire resistance assemblies and products are developed by the design submitter and have been investigated by UL for compliance with applicable requirements. The published information cannot always address every construction nuance encountered in the field.
- When field issues arise, it is recommended the first contact for assistance be the technical service staff provided by the product manufacturer noted for the design. Users of fire resistance assemblies are advised to consult the general Guide Information for each product category and each group of assemblies. The Guide Information includes specifics concerning alternate materials and alternate methods of construction.
- Only products which bear UL's Mark are considered Certified.

BXUV - Fire Resistance Ratings - ANSI/UL 263 Certified for
United States

BXUV7 - Fire Resistance Ratings - CAN/ULC-S101 Certified for
Canada

See General Information for Fire-resistance Ratings - ANSI/UL 263 Certified for United States
Design Criteria and Allowable Variances

See General Information for Fire Resistance Ratings - CAN/ULC-S101 Certified for Canada
Design Criteria and Allowable Variances

Design No. Y634

April 24, 2019

Ratings - 1/2, 3/4, 1, 1-1/2, 2, 2-1/2, 3 and 3-1/2 Hr (See Item 3)

*** Indicates such products shall bear the UL or cUL Certification Mark for jurisdictions employing the UL or cUL Certification (such as Canada), respectively.**

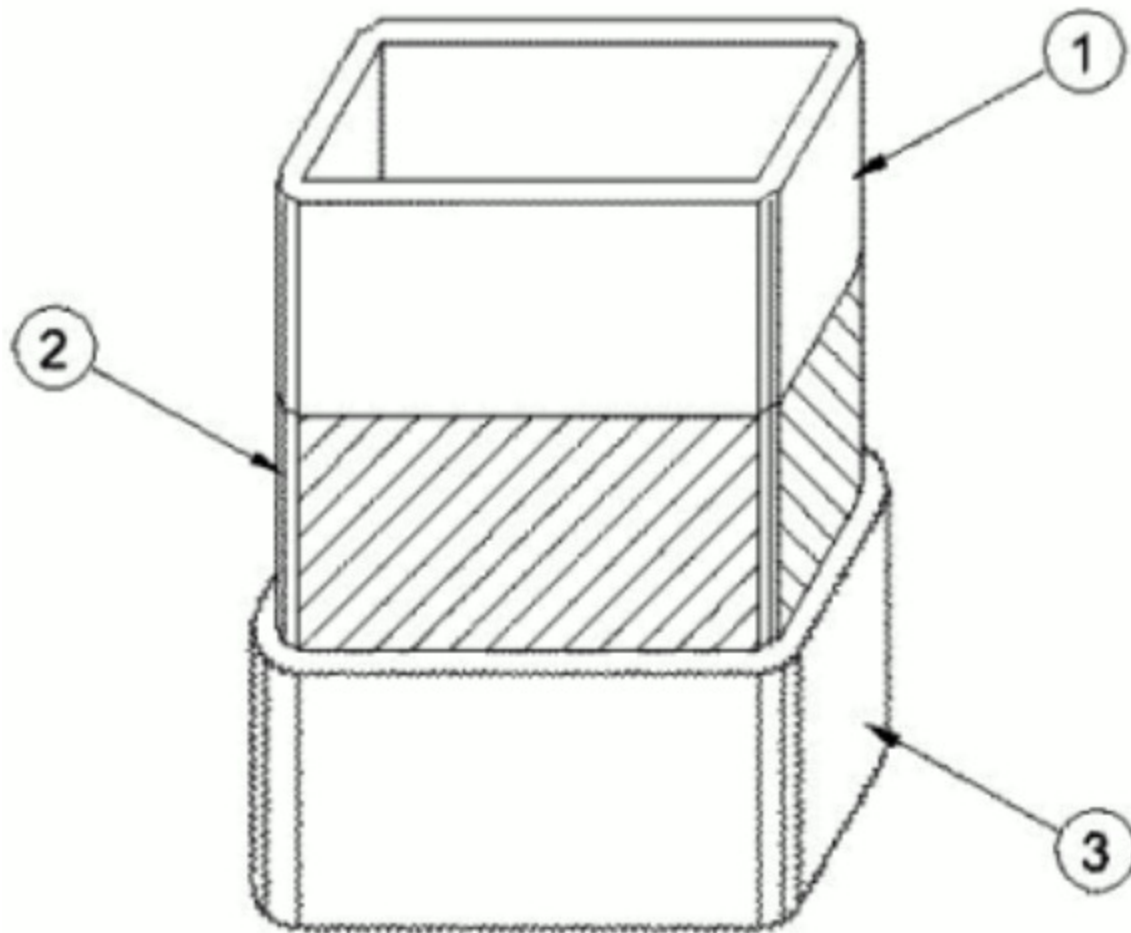

1. **Steel Tube Column** — Steel rectangular tube (ST) or pipe (SP) columns with the minimum sizes shown in the tables below.

2. **Primer Coating** — 60 micron (2 mil) thickness of a two component epoxy primer or 60 micron (2 mil) thickness of an alkyd primer or 60 micron (2 mil) thickness of an acrylic primer or 60 micron (2 mil) thickness of a polyurethane primer.

3. **Mastic & Intumescent Coating*** — Coating spray or brush applied in accordance with the manufacturer's instructions at the minimum average dry thickness shown in the thickness below. The thickness shown does not include primer thickness.

4. **Top Coat (not shown)** — The following topcoats shall be used for compliance with Exterior Environmental Exposure requirement. Solvent Based 2 pack topcoat Type Hensotop 2K PU applied at a dry film thickness of 100 microns (4 mil) or Acrylic polyurethane topcoat Type Hi Solids Polyurethane 250 applied at a dry film thickness of 100 microns (4 mil).

As an alternate to the table below, the required thickness of coating (in mm) to be applied to surfaces of steel tube (ST) and steel pipe (SP) columns may be determined from the equations listed below. The equations may only be used for the indicated hourly rating, and for the corresponding listed ranges of thickness and Hp/A.

Hourly Rating	Thickness Equation (mm)	Thickness Equation (mm)	Hp/A Section Factor Range
60 mins	$T = ((0.0248 * Hp/A) - 0.4909)$	1.12 to 3.65	65 - 167
90 mins	$T = ((0.0302 * Hp/A) + 0.8859)$	2.85 to 5.93	65 - 167
120 mins	$T = ((0.0383 * Hp/A) + 1.8097)$	4.30 to 8.21	65 - 167

T = Thickness of coating in mm

Hp/A	Required Thickness (mm)							
	Rating Period (min)							
	30	45	60	90	120	150	180	210
303	4.84	4.84	N/A	N/A	N/A	N/A	N/A	N/A
213	3.4	3.61	4.06	6.78	10.04	N/A	N/A	N/A
167	2.46	2.51	3.65	5.93	8.21	N/A	N/A	N/A
165	N/A	2.47	3.60	5.87	8.13	N/A	N/A	N/A
160	N/A	2.36	3.48	5.72	7.94	N/A	N/A	N/A
155	N/A	2.25	3.35	5.57	7.75	N/A	N/A	N/A
150	N/A	2.14	3.23	5.42	7.55	N/A	N/A	N/A
145	N/A	2.03	3.11	5.26	7.36	N/A	N/A	N/A
140	N/A	1.92	2.98	5.11	7.17	N/A	N/A	N/A
135	N/A	1.81	2.86	4.96	6.98	N/A	N/A	N/A
130	N/A	1.70	2.73	4.81	6.79	N/A	N/A	N/A
125	N/A	1.58	2.61	4.66	6.60	N/A	N/A	N/A
120	N/A	1.47	2.49	4.51	6.41	N/A	N/A	N/A
115	N/A	1.36	2.36	4.36	6.21	N/A	N/A	N/A
110	N/A	1.25	2.24	4.21	6.02	N/A	N/A	N/A
105	N/A	1.14	2.11	4.06	5.83	N/A	N/A	N/A
100	N/A	N/A	1.99	3.91	5.64	N/A	N/A	N/A
95	N/A	N/A	1.87	3.75	5.45	N/A	N/A	N/A
90	N/A	N/A	1.74	3.60	5.26	N/A	N/A	N/A
85	N/A	N/A	1.62	3.45	5.07	6.28	7.19	8.14
80	N/A	N/A	1.49	3.30	4.87	6.28	7.19	8.14
75	N/A	N/A	1.37	3.15	4.68	6.28	7.19	8.14
70	N/A	N/A	1.25	3.00	4.49	6.28	7.19	8.14
65	N/A	N/A	1.12	2.85	4.30	6.28	7.19	8.14

A/P	Required Thickness (in.)							
	Rating Period (min)							
	30	45	60	90	120	150	180	210

0.130	0.191	0.191	N/A	N/A	N/A	N/A	N/A	N/A
0.185	0.134	0.142	0.160	0.267	0.395	N/A	N/A	N/A
0.236	0.097	0.099	0.144	0.233	0.323	N/A	N/A	N/A
0.239	N/A	0.097	0.142	0.231	0.320	N/A	N/A	N/A
0.246	N/A	0.093	0.137	0.225	0.313	N/A	N/A	N/A
0.254	N/A	0.088	0.132	0.219	0.305	N/A	N/A	N/A
0.262	N/A	0.084	0.127	0.213	0.297	N/A	N/A	N/A
0.272	N/A	0.080	0.122	0.207	0.290	N/A	N/A	N/A
0.281	N/A	0.075	0.117	0.201	0.282	N/A	N/A	N/A
0.292	N/A	0.071	0.112	0.195	0.275	N/A	N/A	N/A
0.303	N/A	0.067	0.108	0.189	0.267	N/A	N/A	N/A
0.315	N/A	0.062	0.103	0.184	0.260	N/A	N/A	N/A
0.328	N/A	0.058	0.098	0.178	0.252	N/A	N/A	N/A
0.342	N/A	0.054	0.093	0.172	0.245	N/A	N/A	N/A
0.358	N/A	0.049	0.088	0.166	0.237	N/A	N/A	N/A
0.375	N/A	0.045	0.083	0.160	0.230	N/A	N/A	N/A
0.394	N/A	N/A	0.078	0.154	0.222	N/A	N/A	N/A
0.414	N/A	N/A	0.073	0.148	0.214	N/A	N/A	N/A
0.437	N/A	N/A	0.069	0.142	0.207	N/A	N/A	N/A
0.463	N/A	N/A	0.064	0.136	0.199	0.247	0.283	0.320
0.492	N/A	N/A	0.059	0.130	0.192	0.247	0.283	0.320
0.525	N/A	N/A	0.054	0.124	0.184	0.247	0.283	0.320
0.562	N/A	N/A	0.049	0.118	0.177	0.247	0.283	0.320
0.606	N/A	N/A	0.044	0.112	0.169	0.247	0.283	0.320

HILTI CONSTRUCTION CHEMICALS, DIV OF HILTI INC — Fire Finish CFP-SP WB investigated for Conditioned Interior Space Purpose and Interior General Purpose

HILTI CONSTRUCTION CHEMICALS, DIV OF HILTI INC — Fire Finish CFP-SP WB investigated for exterior environmental purpose WITH TOPCOAT - TYPE HENSOTOP 2K PU or TYPE HI SOLIDS POLYURETHANE 250

*** Indicates such products shall bear the UL or cUL Certification Mark for jurisdictions employing the UL or cUL Certification (such as Canada), respectively.**

Last Updated on 2019-04-24

The appearance of a company's name or product in this database does not in itself assure that products so identified have been manufactured under UL's Follow-Up Service. Only those products bearing the UL Mark should be considered to be Certified and covered under UL's Follow-Up Service. Always look for the Mark on the product.

UL permits the reproduction of the material contained in the Online Certification Directory subject to the following conditions: 1. The Guide Information, Assemblies, Constructions, Designs, Systems, and/or Certifications (files) must be presented in their entirety and in a non-misleading manner, without any manipulation of the data (or drawings). 2. The statement "Reprinted from the Online Certifications Directory with permission from UL" must appear adjacent to the extracted material. In addition, the reprinted material must include a copyright notice in the following format: "© 2019 UL LLC"