



Seismic design of steel and hybrid steel-concrete structures

José Miguel Castro

27 March 2025

Consequences of seismic events



Hatay province

SUBSCRIBE

Consequences of seismic events



Consequences of seismic events



Consequences of seismic events



Consequences of seismic events



Consequences of seismic events



Consequences of seismic events



Consequences of seismic events



Consequences of seismic events



Source: Lignos, 2015



Christchurch EQ M 6.1, 2011

Consequences of seismic events

Local buckling of members and excessive panel zone demands



Consequences of seismic events

Buckling and fracture of bracing elements

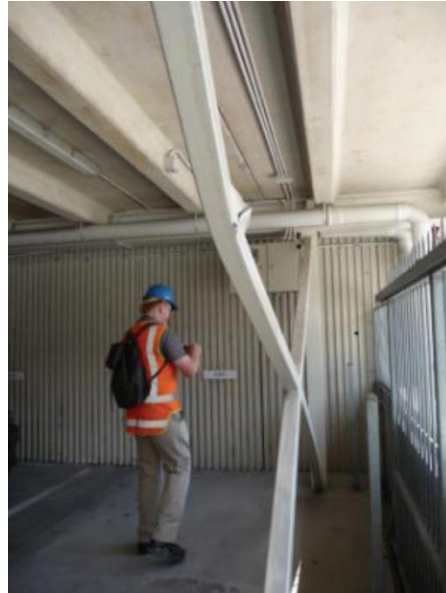

Koyama et al 2012



Matsumoto et al 2012; Clifton et al 2011

Consequences of seismic events

Concrete crushing, fracture of bolts and gusset plates at column bases



Matsumoto *et al*, 2012



Midorikawa *et al* 2012

Source: Lignos, 2015

Christchurch EQ M 6.1, 2011

Seismic design

Main objectives defined in Eurocode 8

1. Protection of human life through **prevention of structural collapse**

→ EQ return period: **475 years**

2. **Limitation of damage** for more frequent seismic events

→ EQ return period: **95 years**

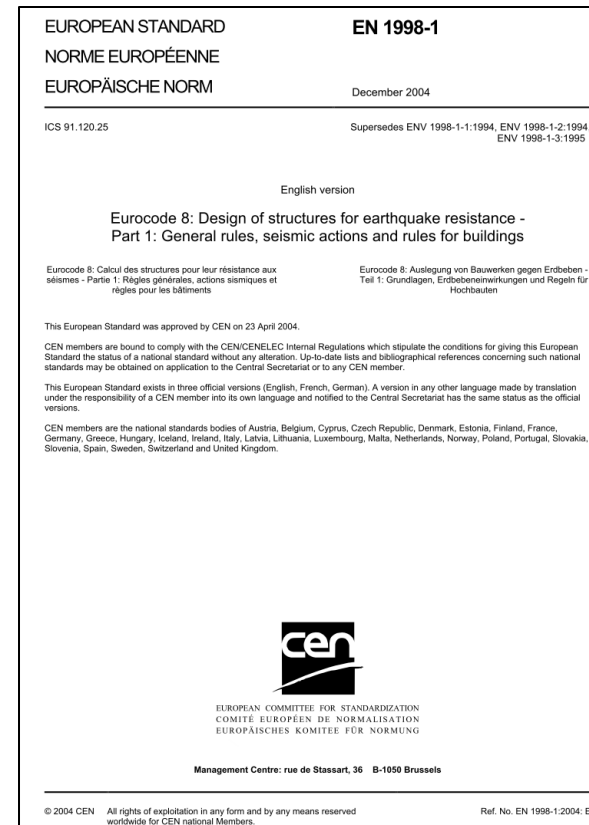

Seismic design

Prevention of structural collapse: How to achieve?

Design for **linear elastic response** → Several challenges!

- **Expensive** (€)
- Lateral resistance > **25% Weight** → Architectural issues!
- EQ intensity has a probability of being exceeded

Design for **inelastic response** (weak structures) → Advantages

- **Cheaper** solutions (€)
- **Slender** structures
- ... but some **damage is expected!**

Seismic design

Design for inelastic response: the importance of ductility

Cantilever

HE steel profile

Modelled in ABAQUS (shell elements)

Steel material: nonlinear model

EQ: 3 intensity levels

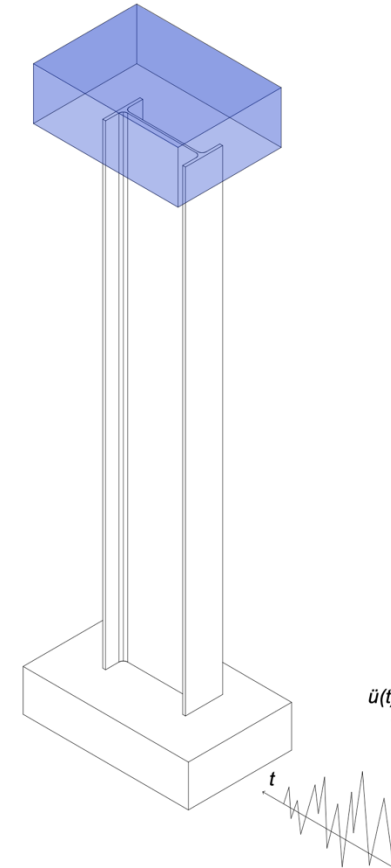

Ductility

PGA = 0.1g

Ductility

Material



Sectional

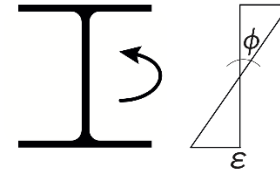

Global

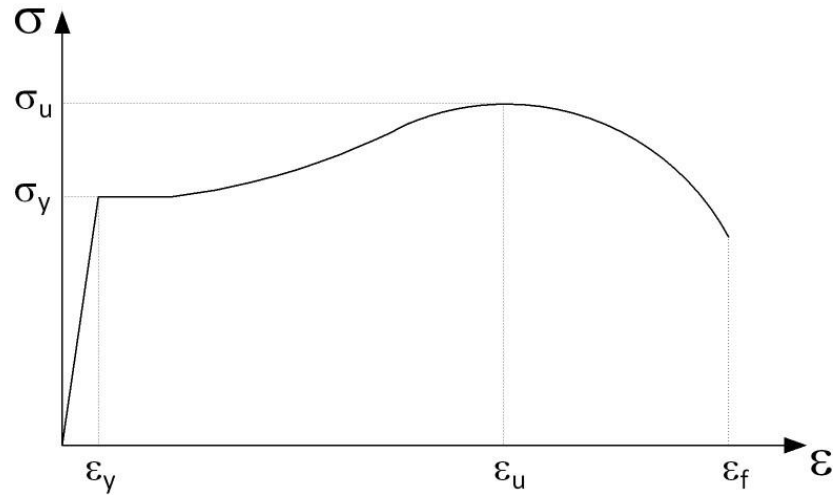
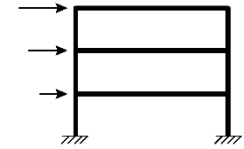

$$\mu_{\varepsilon} = \frac{\varepsilon_u}{\varepsilon_y}$$

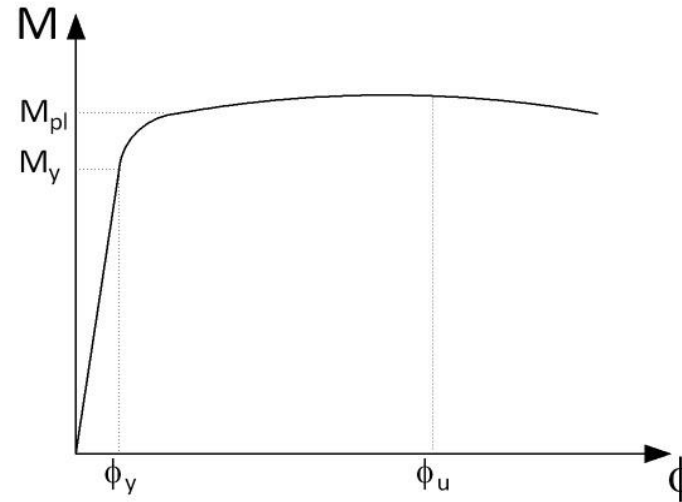

$$\mu_{\phi} = \frac{\phi_u}{\phi_y}$$

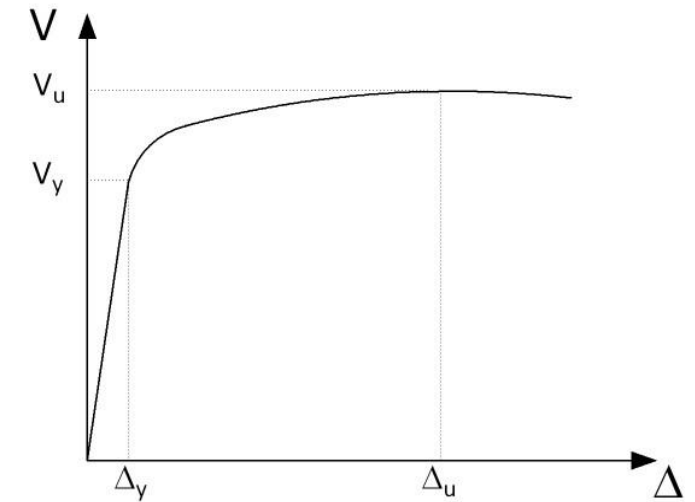

$$\mu_{\Delta} = \frac{\Delta_u}{\Delta_y}$$

Ductility

Material



Sectional

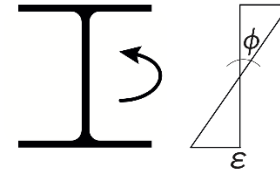

Global

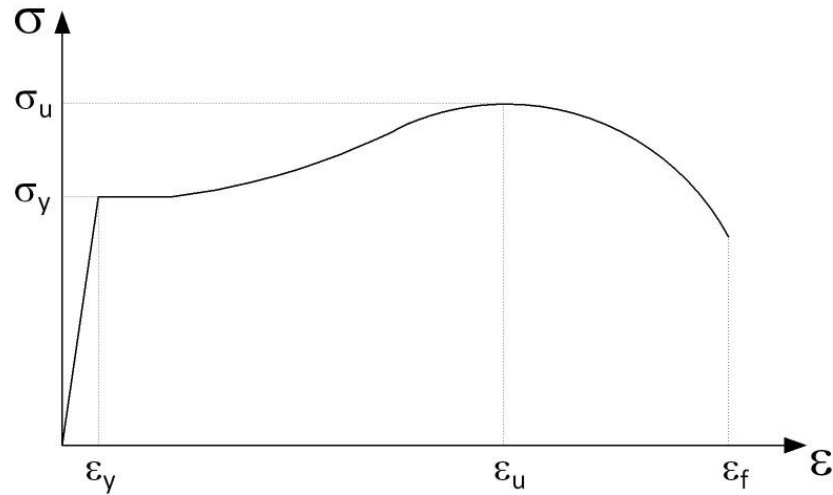
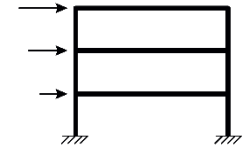

$$\mu_\epsilon = \frac{\epsilon_u}{\epsilon_y}$$

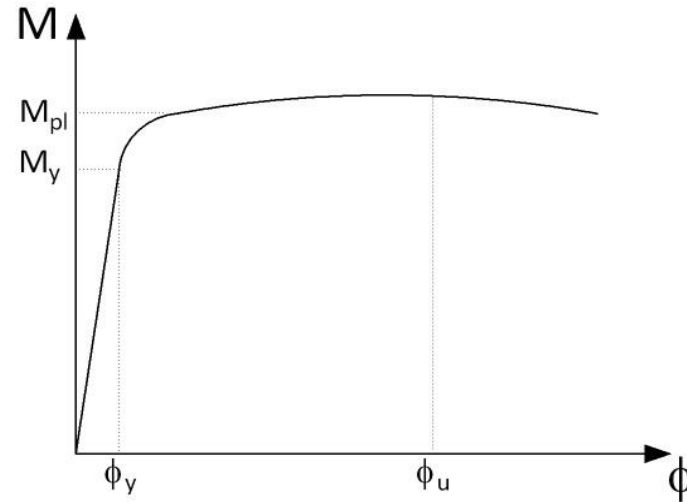

$$\mu_\phi = \frac{\phi_u}{\phi_y}$$

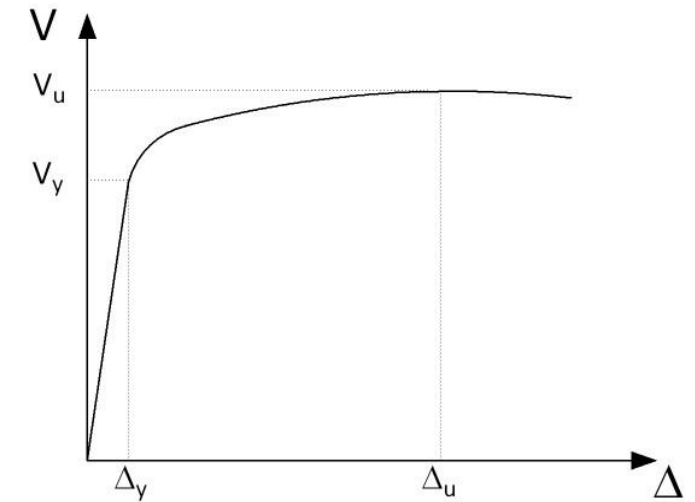

$$\mu_\Delta = \frac{\Delta_u}{\Delta_y}$$

Seismic design

Where is ductility explored in multi-storey steel buildings?

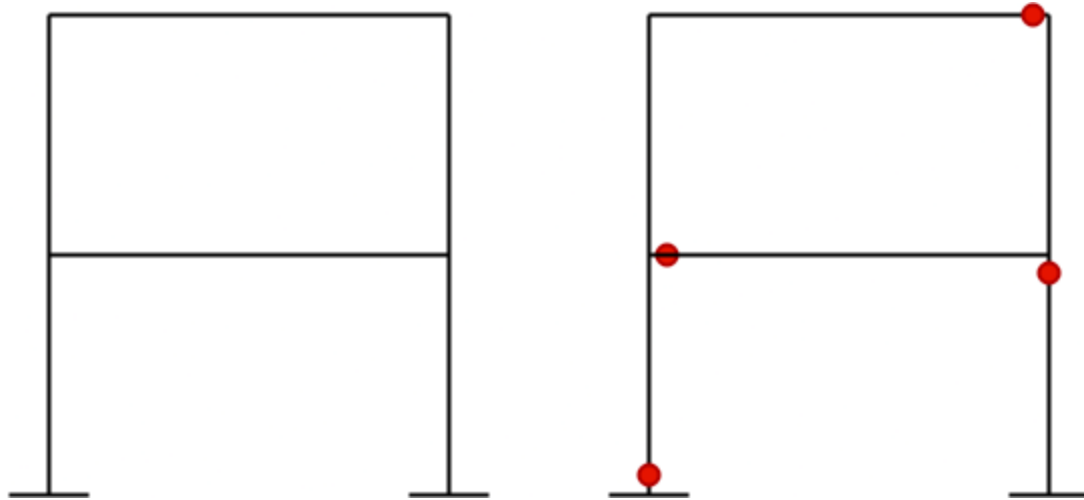

Moment-Resisting Frames

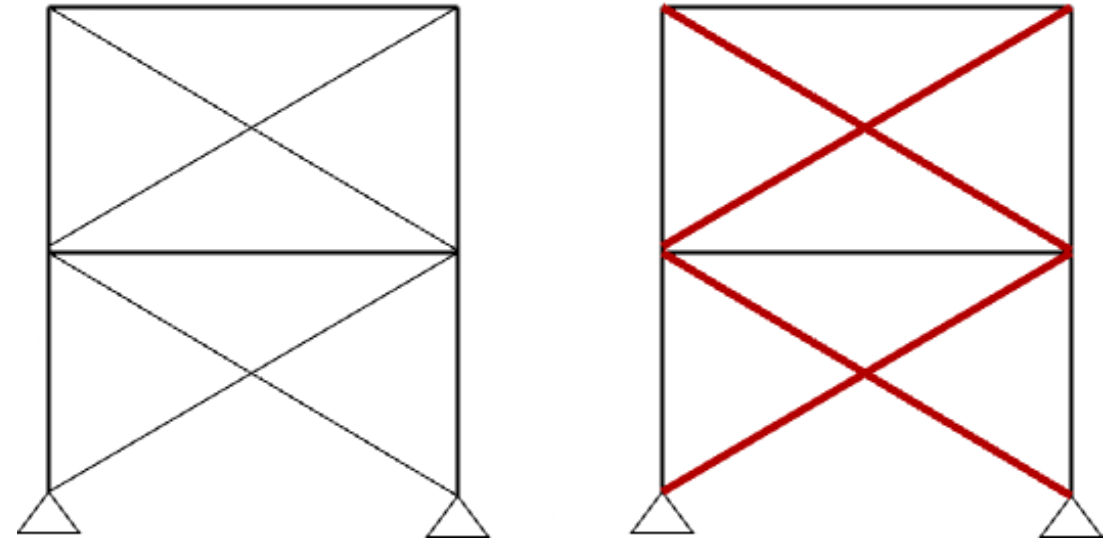

Concentrically-Braced Frames

Seismic design

Connections

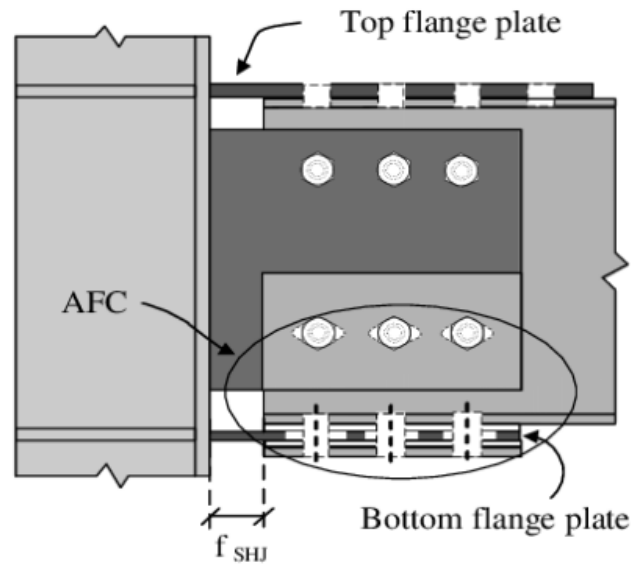

Dissipative connections

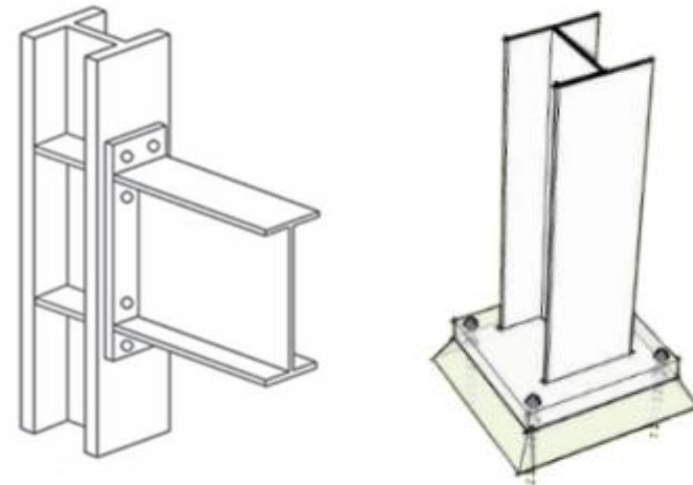

Non-dissipative connections

Ductility

The behaviour factor

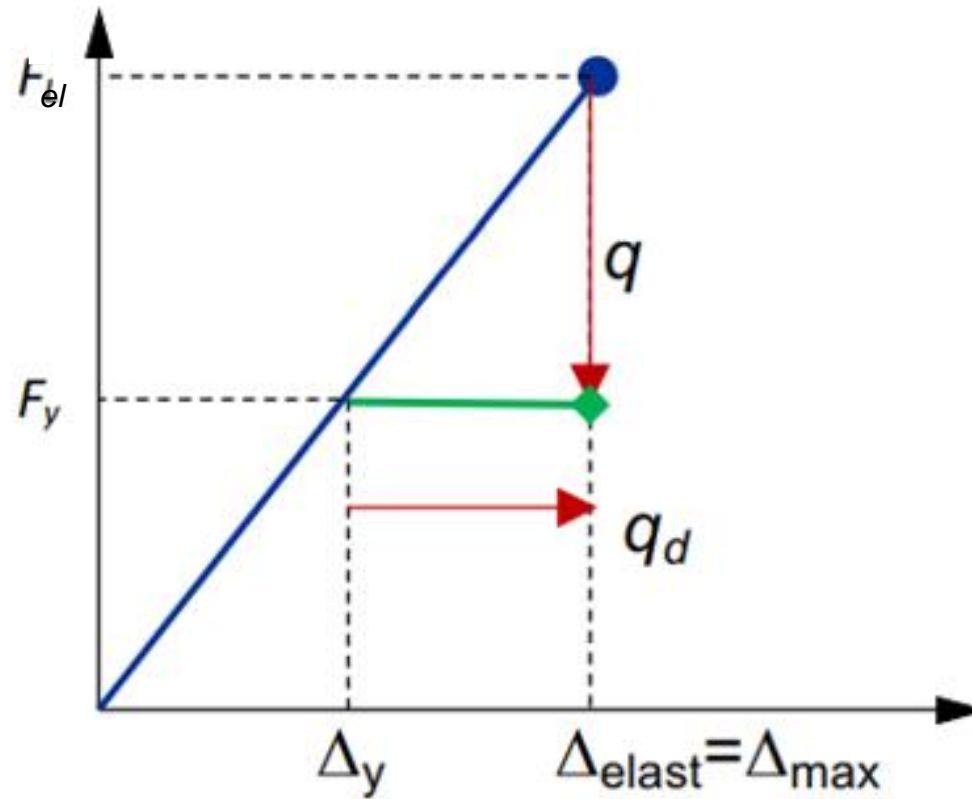

Ductility

Material 

Sectional 

Global 

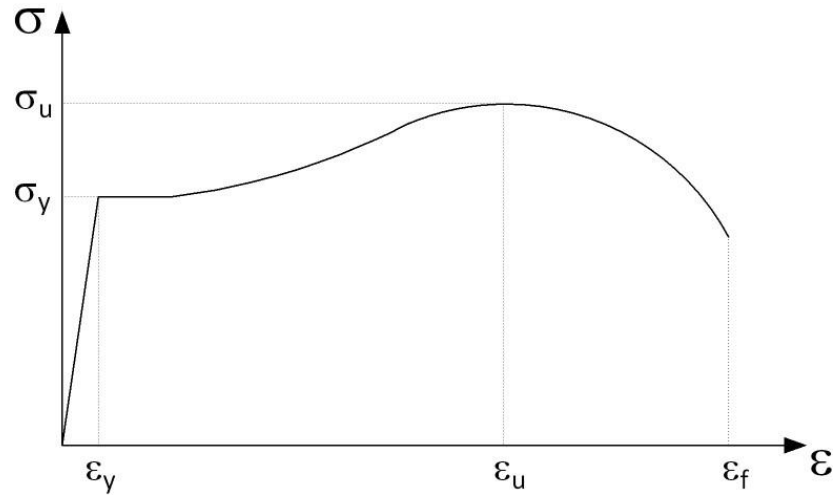

$$\mu_\epsilon = \frac{\epsilon_u}{\epsilon_y}$$

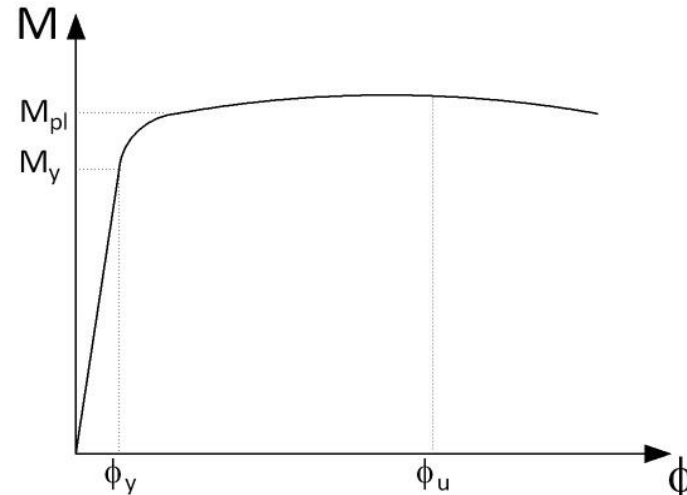

$$\mu_\phi = \frac{\phi_u}{\phi_y}$$

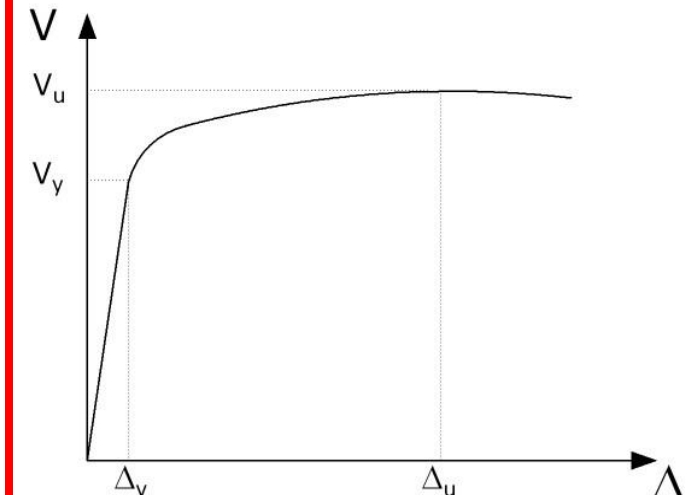

$$\mu_\Delta = \frac{\Delta_u}{\Delta_y}$$

Ductility

Problems due to lack of global ductility: soft-storey mechanisms



Kobe, 1995

Ductility

How to ensure global ductility?

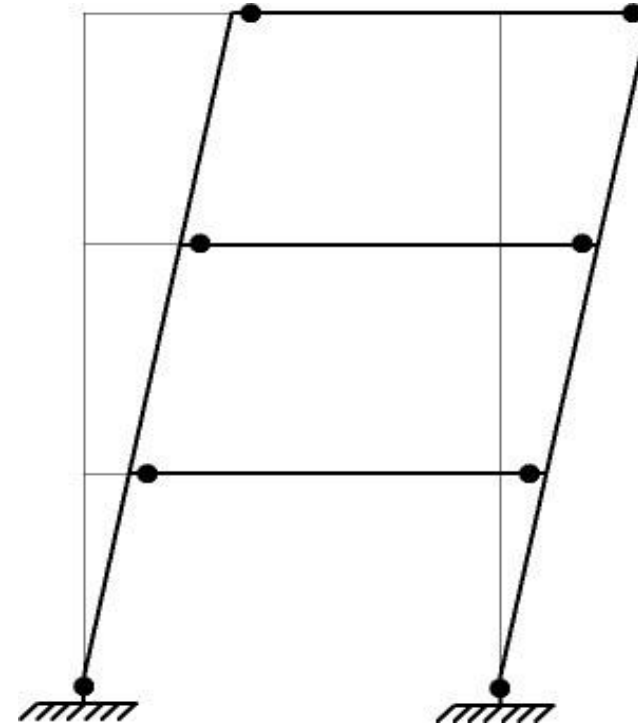
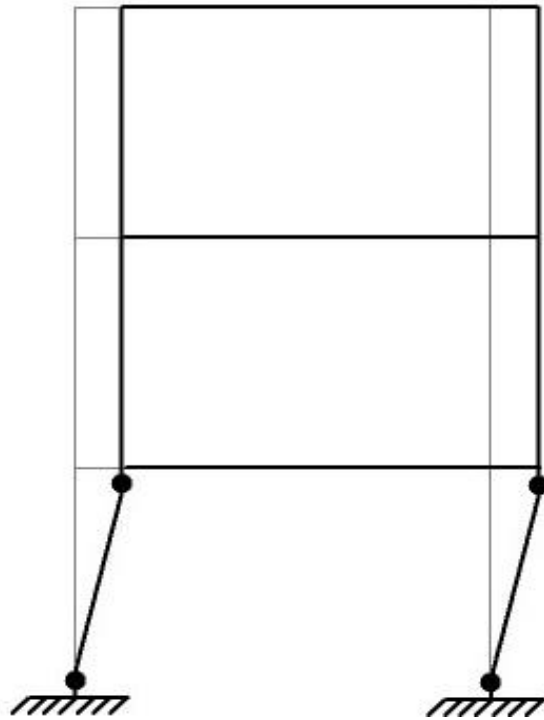

Ductility

Capacity design

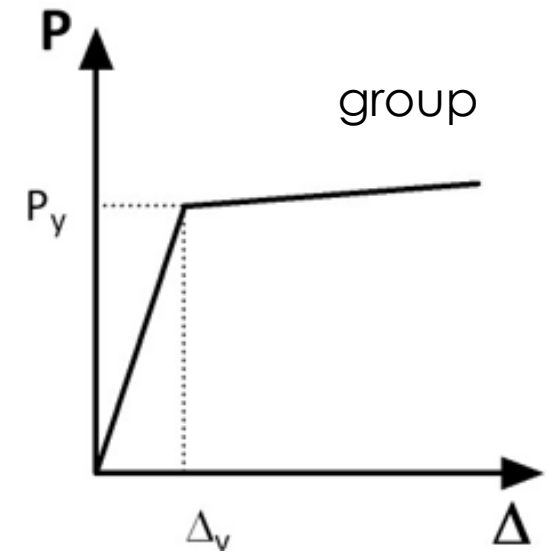
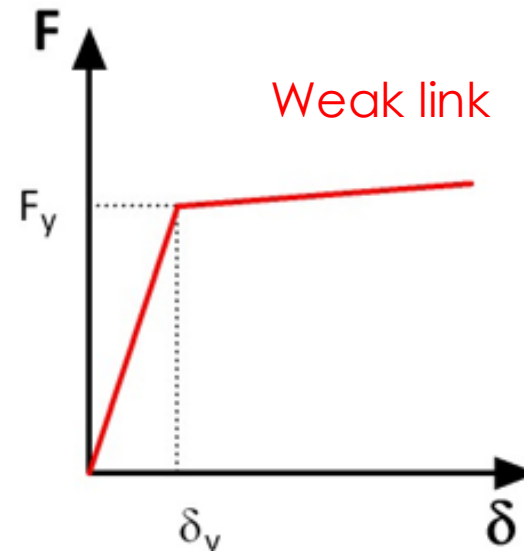
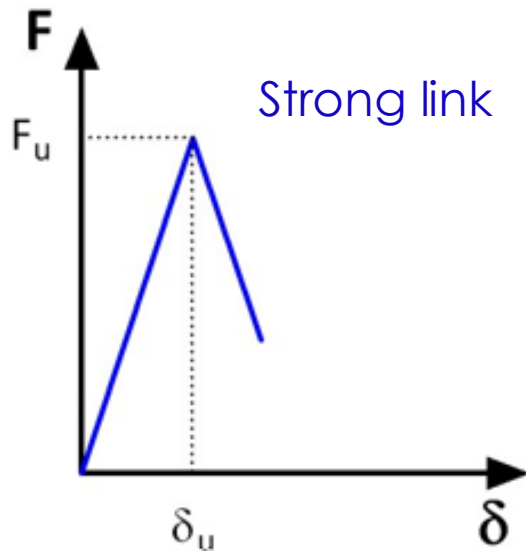
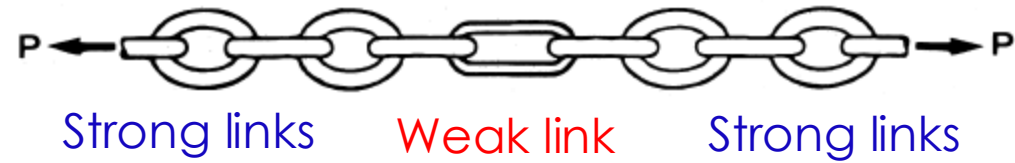

Ductility

In Moment-Resisting Frames

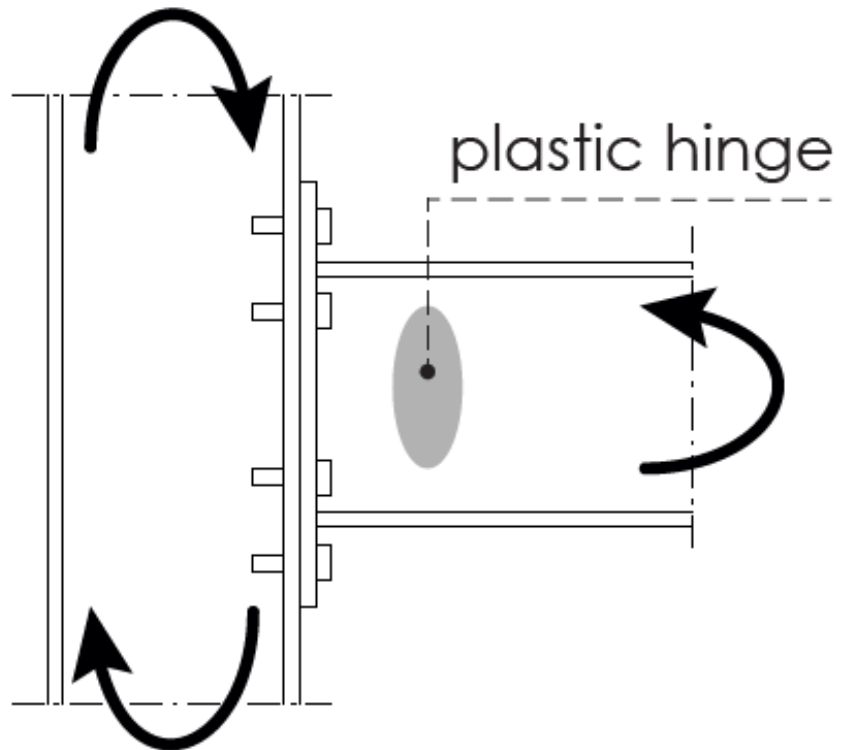

Columns:

$$\sum M_{RC} \geq 1.3 \sum M_{RB}$$

Seismic design of steel buildings

1. Identify/choose the lateral load resisting system

Source: AISC / Michael Engelhardt

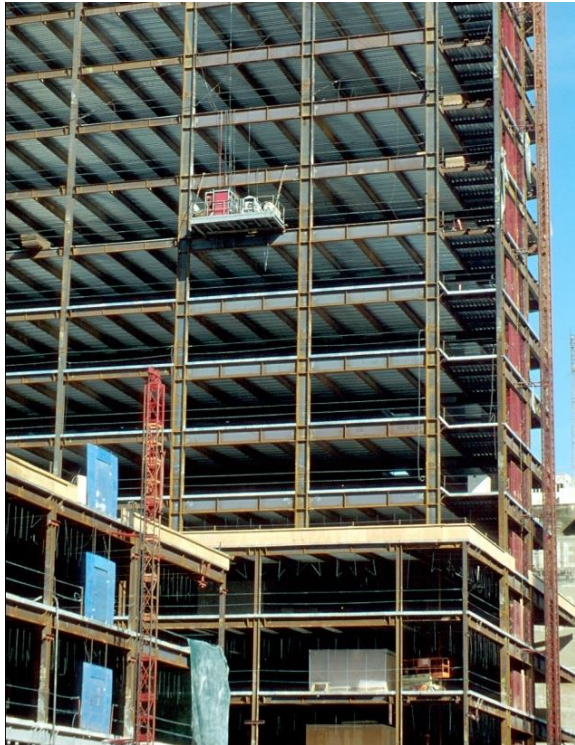

MRF



CBF



EBF

Seismic design of steel buildings

2. Pick a value for the behaviour factor: **system** and **ductility class**

STRUCTURAL TYPE	Ductility Class	
	DCM	DCH
a) Moment resisting frames	4	$5\alpha_w/\alpha_1$
b) Frame with concentric bracings		
Diagonal bracings	4	4
V-bracings	2	2,5
c) Frame with eccentric bracings	4	$5\alpha_w/\alpha_1$
d) Inverted pendulum	2	$2\alpha_w/\alpha_1$
e) Structures with concrete cores or concrete walls	See section 5	
f) Moment resisting frame with concentric bracing	4	$4\alpha_w/\alpha_1$
g) Moment resisting frames with infills		
Unconnected concrete or masonry infills, in contact with the frame	2	2
Connected reinforced concrete infills	See section 7	
Infills isolated from moment frame (see moment frames)	4	$5\alpha_w/\alpha_1$

Seismic design of steel buildings

3. Define the inelastic response spectrum and evaluate base shear

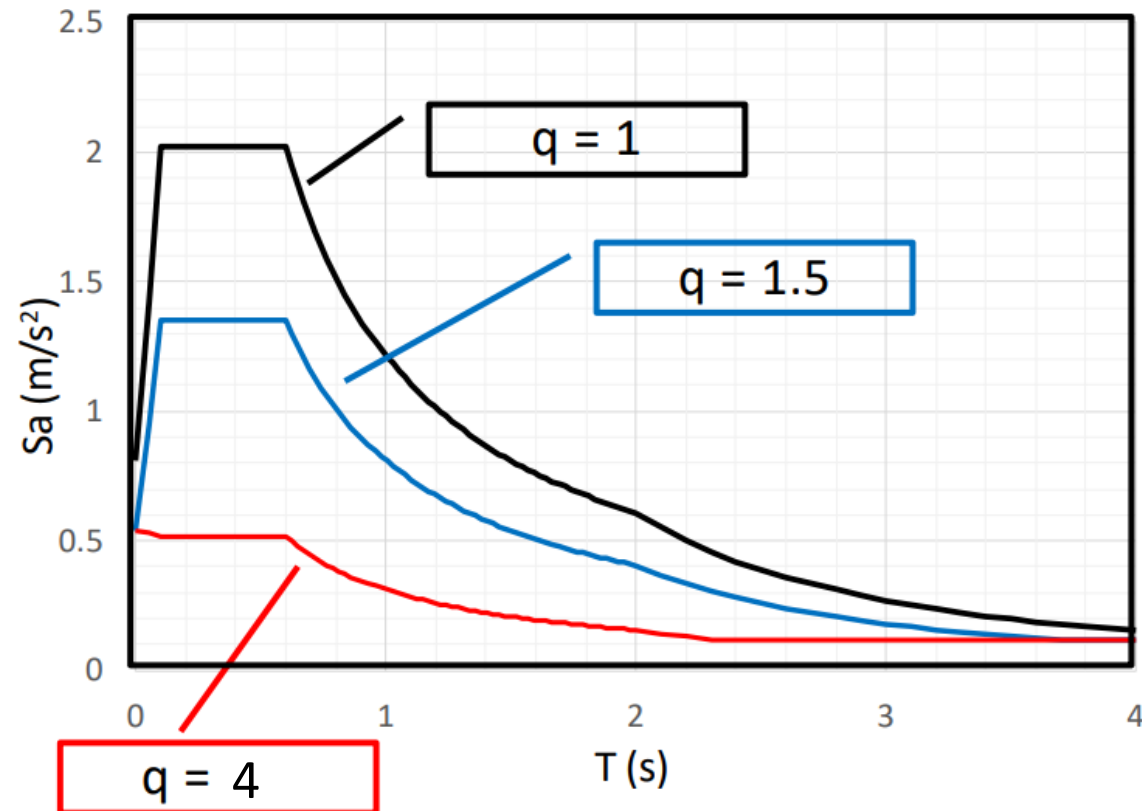

Seismic design of steel buildings

4. Perform design checks on the **dissipative** elements
- Cross-section classification
 - Limitation of axial force levels in flexural members
 - Control of brace slenderness in CBF
 - Other checks

Seismic design of steel buildings

5. Apply capacity design principles to design the **non-dissipative** elements and ensure global ductility
- Column design in MRF
 - Beam and column design in CBF
 - **Connection design (beam-to-column, column bases)**

Seismic design of steel buildings

Non-dissipative connections (beam-to-columns/walls)

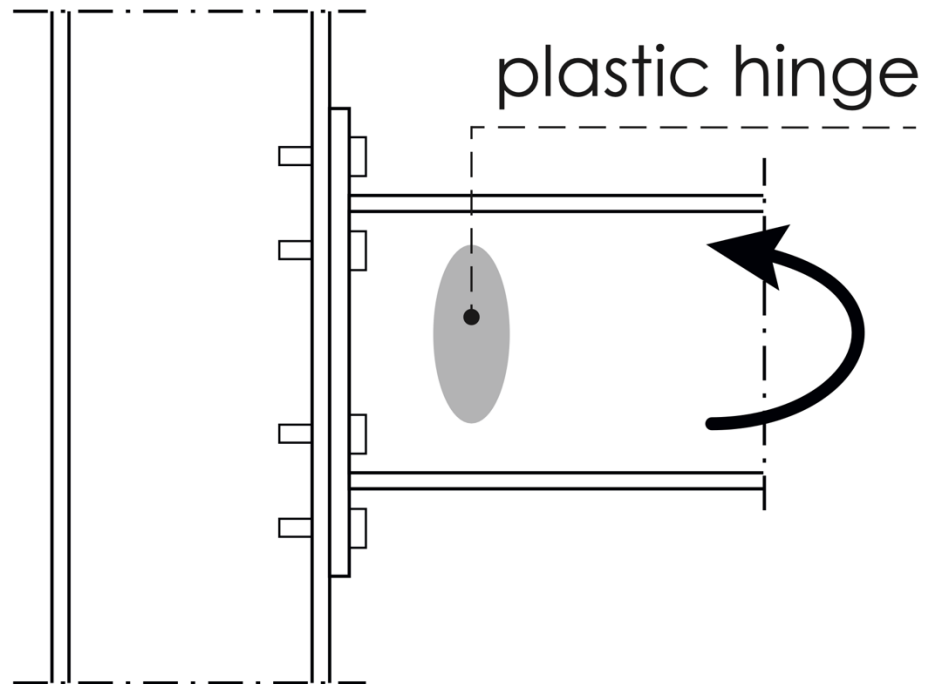

Connection design: $R_d \geq 1.1 * \gamma_{ov} * R_{fy}$

Where:

R_d is the resistance of the connection according to EC3

R_{fy} is the plastic resistance of the connected dissipative member based on the yield stress of the material

γ_{ov} is the overstrength factor (=1.25)

Seismic design of steel buildings

Non-dissipative connections (column bases)

- Action effects for foundation elements shall be based on capacity design, considering possible overstrength, but need **not exceed** those from an elastic **seismic response** ($q = 1.0$);
- For foundations of individual vertical elements (walls or columns)

$$E_{Fd} = E_{F,G} + \gamma_{Rd} \cdot \Omega \cdot E_{F,E}$$

where $\gamma_{Rd}=1.0$ for $q \leq 3.0$ or $\gamma_{Rd}=1.2$ for $q > 3.0$ and $\Omega = \min(M_{Rd}/M_{Ed})$;

- For foundations of **concentric braced frames** : $\Omega = \min(N_{Rd}/N_{Ed})$;
- For foundations of **eccentric braced frames** : $\Omega = \min(V_{Rd}/V_{Ed})$ among all short seismic links and $\Omega = \min(M_{Rd}/M_{Ed})$ among all intermediate and long links ;

Seismic design of steel buildings

Non dissipative connections (beam – to – RC column)

- Seismic design:
 - $g=2.5 \text{ kN/m}^2$; $q=1.5 \text{ kN/m}^2$
 - Influence width = 3 m
 - **IPE 200** ($M_{pl,Rd} = 52 \text{ kN.m}$)
 - $L = 6 \text{ m}$
 - $V_{G+0.3Q} = 27.5 \text{ kN}$

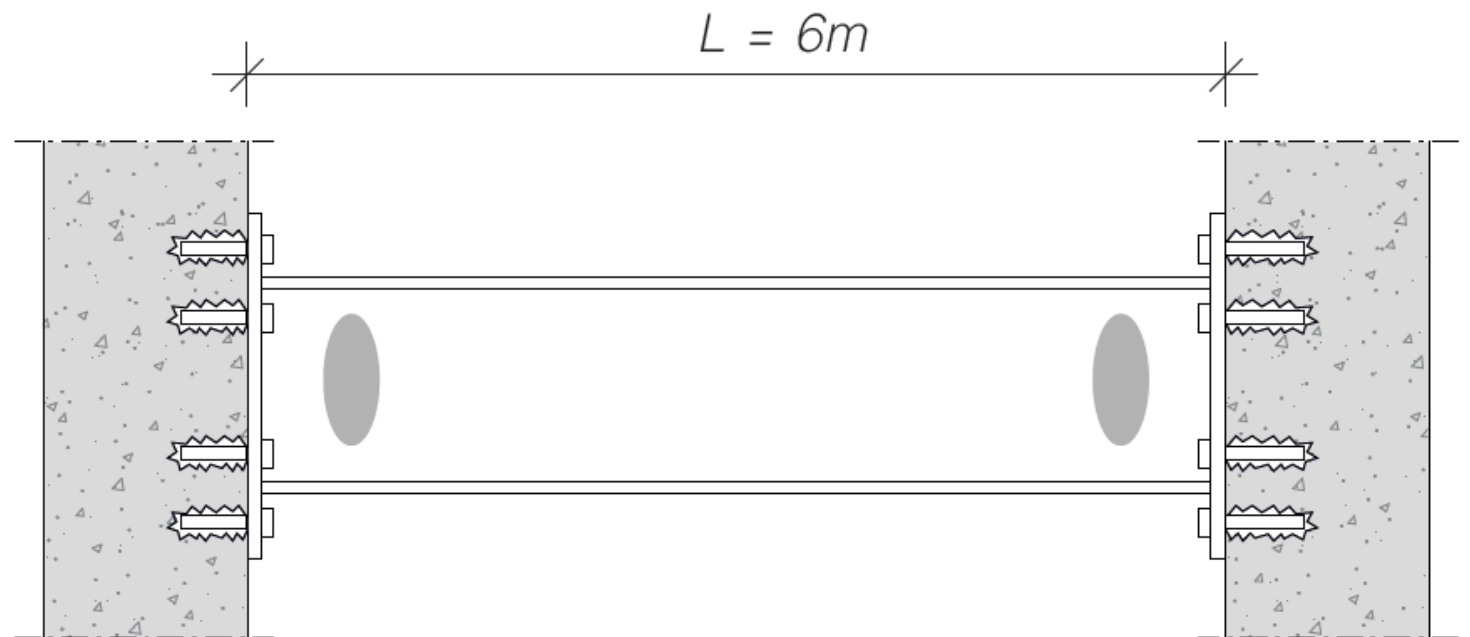

Seismic design of steel buildings

Non dissipative connections (beam-to-column)

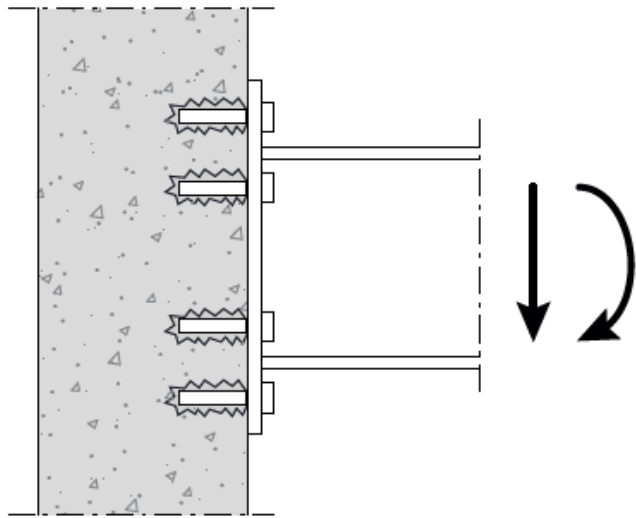

$$M_{Ed} = 1.1 \cdot \gamma_{ov} \cdot M_{pl} = 71.3 \text{ kNm}$$

$$V_{Ed} = V_{G+0.3Q} + 2 \cdot \left(1.1 \cdot \gamma_{ov} \cdot \frac{M_{pl}}{L} \right) = 51.3 \text{ kN}$$

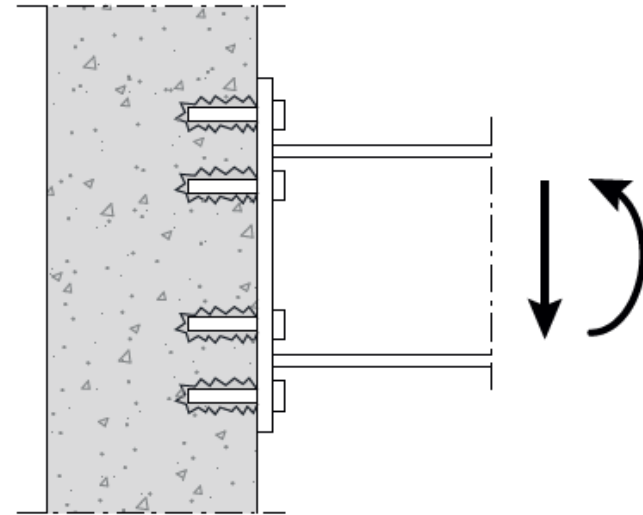

$$M_{Ed} = 1.1 \cdot \gamma_{ov} \cdot M_{pl} = 71.30 \text{ kNm}$$

$$V_{Ed} = V_{G+0.3Q} - 2 \cdot \left(1.1 \cdot \gamma_{ov} \cdot \frac{M_{pl}}{L} \right) = 3.8 \text{ kN}$$

Seismic design of steel buildings

Non dissipative connections (column - foundation)

- Seismic design:
 - $T_1 = 1.1s$
 - $q = 4$
 - $S_{d1}(T_1) = 0.13 \text{ (m/s}^2\text{)} - \text{Porto}$
 - $\lambda_1 = 1.0 \text{ (} T_1 > 2T_C \text{)}$
 - Design base shear (F_{b1}) = 22 kN
 - Sections: columns **HEB400**
beams **IPE270**
braces **CHS 76.1x3.2**

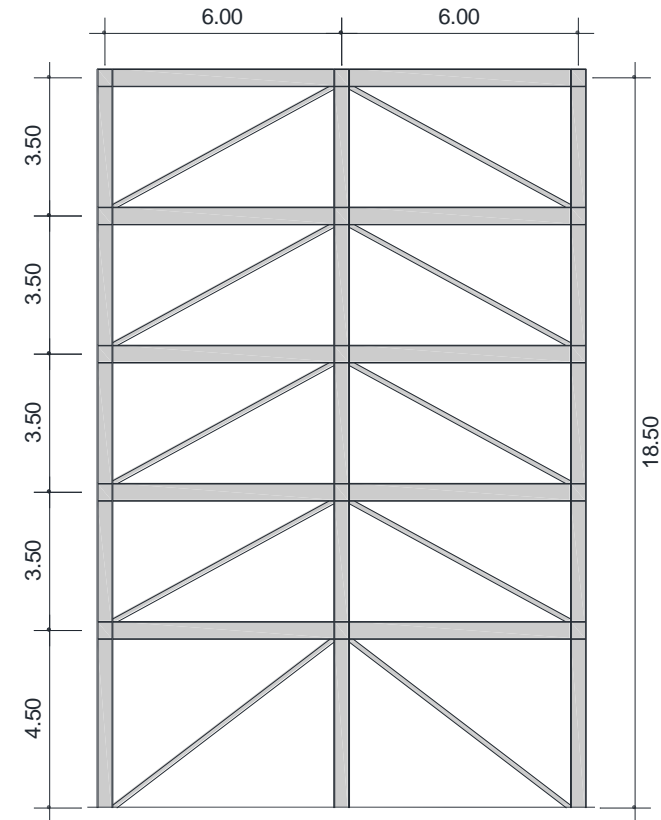

Seismic design of steel buildings

Non dissipative connections (column base)

- Input for the design of connection

$$E_d = E_{d,Gk+0.3Qk} + 1.1Y_{Rd} \Omega E_{d,E}$$

$$Y_{Rd} = 1.2 \text{ and } \Omega_{\min} = (N_{pl,Rd,i}/N_{Ed,i}) = 4.3$$

$$E_d = E_{d,Gk+0.3Qk} + 5.67E_{d,E}$$

	q=4.0			q=1.0
	$E_{d,Gk+0.3Qk}$	$E_{d,E}$	E_d	Gk+0.3Qk+E
M (KN.m)	0.0	0.0	0.0	0.0
V (kN)	0.0	0.1	0.4	0.2
N (kN)	191.9	77.0	628.6	471.8

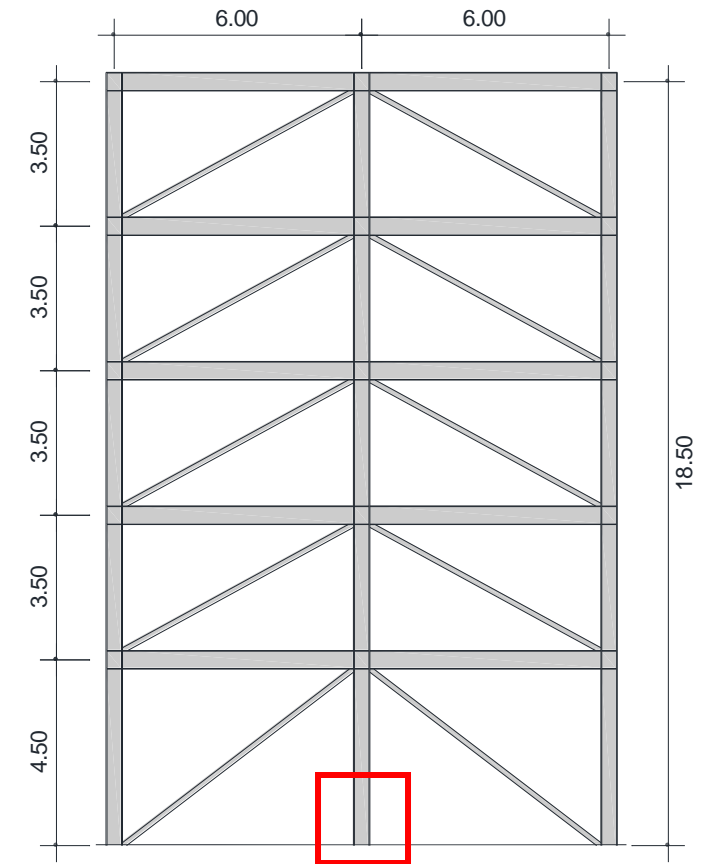



Thank you!

27 March 2025