

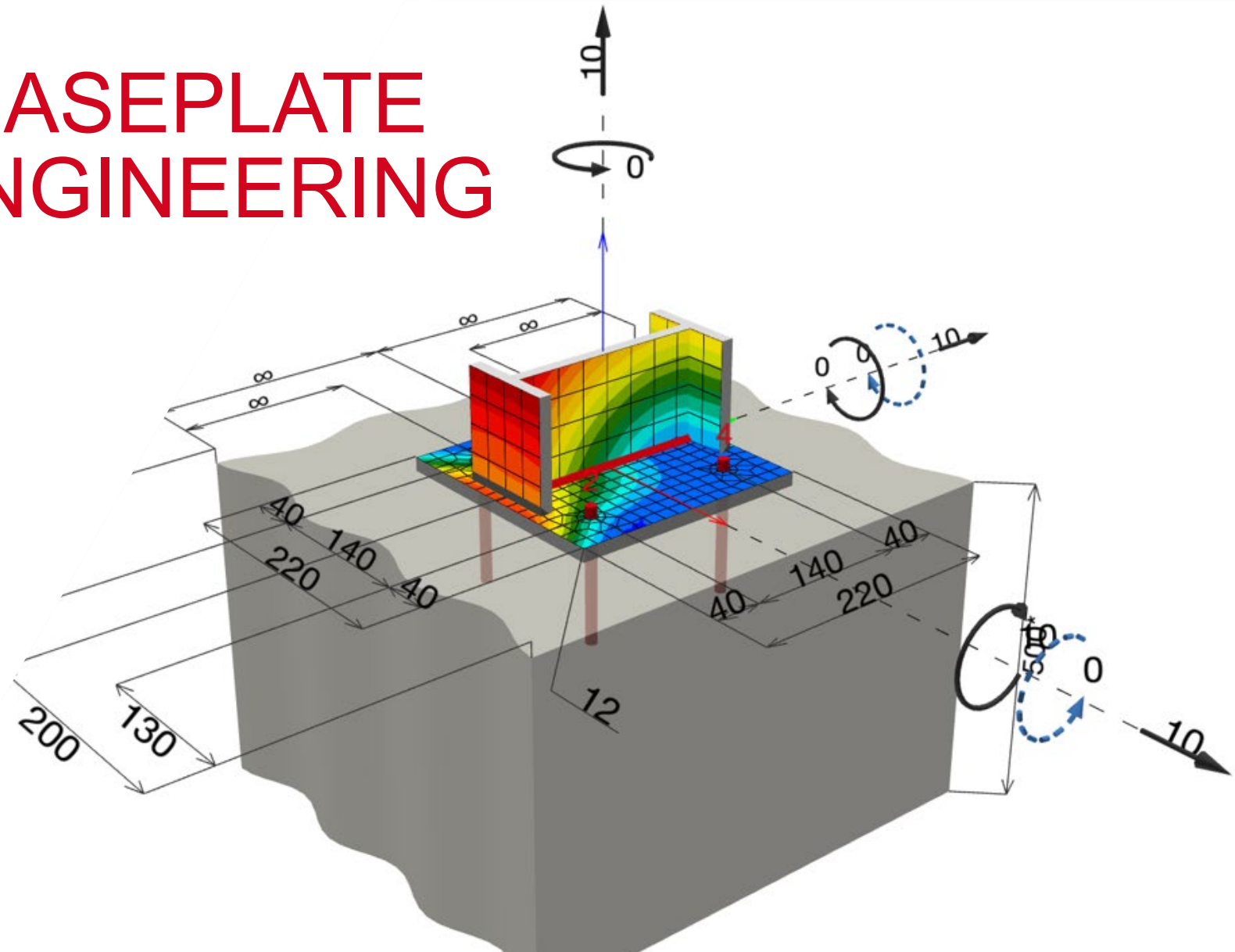

DESIGN YOUR BASEPLATE WITH PROFIS ENGINEERING & CBFEM

Rickard Bergeryd
Anchor Expert
Carlos Taborda
Technical Marketing Manager
May 25, 2021



AGENDA

- **Design of Fasteners For Use In Concrete According to EN 1992-4**
- Design Your Baseplate With PROFIS Engineering – Assuming a Rigid Baseplate
- Design Your Baseplate With PROFIS Engineering – Using CBFEM
- Questions & Answers

EN 1992-4 DESIGN OF FASTENINGS FOR USE IN CONCRETE

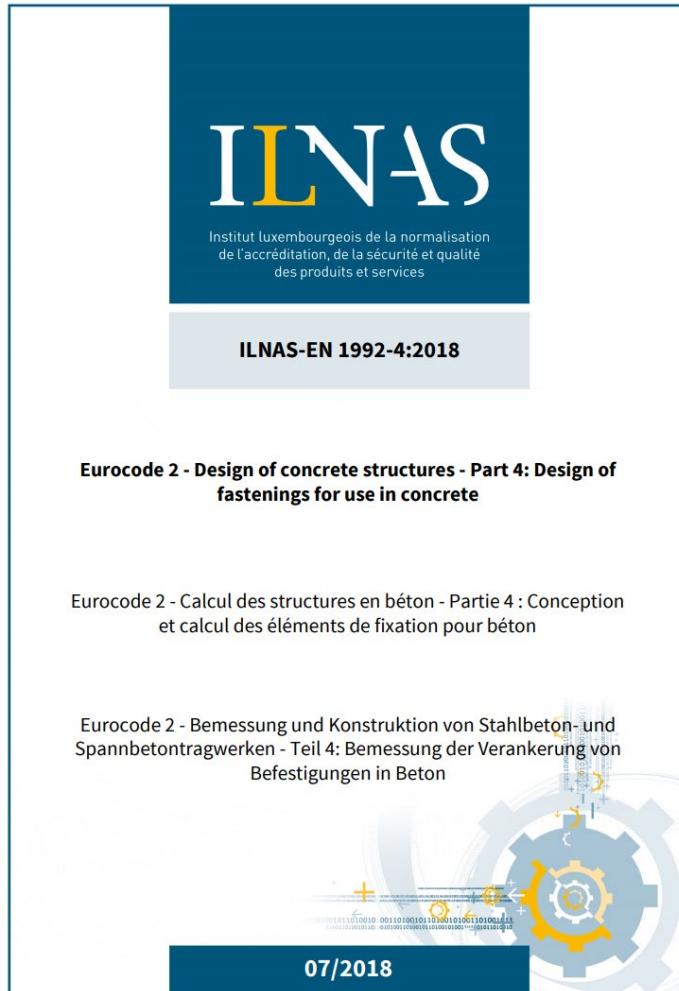

- A specification shall typically include manufacturer, type and geometry of the fasteners. **Fastenings shall no be changed unless verified and approved by the responsible designer.** (EN 1992-4:2018; 4.5)

- Always assume that the **concrete is cracked** over its service life unless you can prove the opposite. (EN 1992-4:2018; 4.7)

- The linear strain distribution is valid if the fixture is **sufficiently rigid**, the baseplate remains elastic under design actions and its deformation remains negligible. (EN 1992-4:2018; 6.2.1)

Key

$$N_{Ed, i} = \varepsilon_{s, i} \cdot E_s \cdot A_s$$

$$C_{Ed} = 0,5 \cdot b_{fix} \cdot x \cdot \varepsilon_c \cdot E_c$$

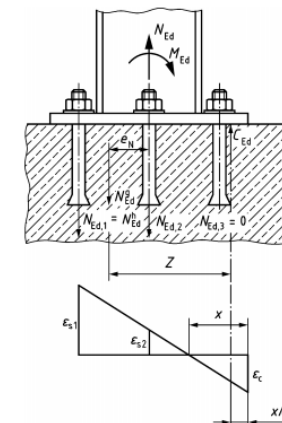

AGENDA

- Design of Fasteners For Use In Concrete According to EN 1992-4
- **Design Your Baseplate With PROFIS Engineering – Assuming a Rigid Baseplate**
- Design Your Baseplate With PROFIS Engineering – Using CBFEM
- Questions & Answers

STARTING POINT OF DESIGN

Given

- Concrete C20/25, cracked, thickness 500 mm
- I profile, I 200
- Centre of profile 200 mm from concrete edge
- V_x : 10 kN, V_y : 10 kN, N : 10 kN, M_x : -10 kNm

My choices

- Baseplate 12 mm, 220 x 220 mm
- 4 chemical anchors Hilti HIT-HY 200 + HAS-U 5.8 M10x170, embedment depth 100 mm

STARTING POINT OF DESIGN

BASE MATERIAL

- Cracked concrete
- C20/25
- Change to 2D

ANCHOR

Family: HIT-HY 200 + HAS-U

Type: HIT-HY 200 + HAS-U 5.8

Size: M10

View ETA approval

Insert item #: 2223709 HAS-U 5.8 M10x170

Mortar item #: 2022896 HIT-HY 200-A

Embedment depth h_{ef} : 100 mm

CONCRETE REINFORCEMENT

Concrete: Wide | Edge: None

Reinforcement to control cracking present

SUPPLEMENTARY REINFORCEMENT

Select reinforcement to prevent concrete breakout

No supplementary reinforcement

ANCHOR LIST

Anchor	N (kN)	Vx (kN)	Vy (kN)
1	32,109	2,5	2,5
2	32,109	2,5	2,5
3	1,849	2,5	2,5
4	1,849	2,5	2,5

ANCHOR DESIGN

Tension

- Steel: 167%
- Concrete breakout: 213%
- Bond: 274%
- Splitting: 0%

Shear

- Steel: 31%
- Concrete edge breakout: 63%
- Pryout: 21%

Combination

- Steel: 286%

NOTIFICATIONS







- Want to know how much anchor and mortar you need to order? Send the design to quantity calculator
- The anchor calculation is based on a rigid baseplate assumption.
- Smart Baseplate Selector: Your current design requirements do

Table: Design Results

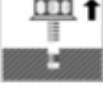
N°	Name	Type	Forces [kN]			Moments [kNm]			Utilisation			
			Vx	Vy	N	Mx	My	Mz	T	S	C	Total
1	Combination 1	Design	10	10	10	-10	0	0	274%	63%	286%	286%
		Sustained			0	0	0					

PARAMETERS AFFECTING THE DESIGN RESISTANCE

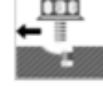
Resistance to possible failure modes

Resistance to parameter	Tension				Shear		
	Steel 	Concrete cone 	Pull-out 	Splitting 	Steel ^{b)} 	Concrete edge 	Pry-out 
h_{ef} : Effective anchorage depth	0	+	0/+ ^{a)}	+	0	+	+
s_1 : Spacing perpendicular to the edge	0	+	0 ^{a)}	+	0	0	+
s_2 : Spacing parallel to the edge	0	+	0 ^{a)}	+	0	+	+
n : Edge distance	0	+	0 ^{a)}	+	0	+	+
n : Number of anchors	+	+	+	+	+	+ ^{d)}	+
d : Element size/diameter	+	0	0/+ ^{a)}	0/+/-	+	+	0
Anchor material (strength class of steel)	+	0	0	0	+	0	0
(l , w) Length and width of the fixture	+ ^{c)}	+ ^{c)}	+ ^{c)}	+ ^{c)}	0	0	0
h : Thickness of base material	0	0	0	+	0	+	0
f_{cc} : Concrete compressive strength	0	+	0/+	+	0	+	+

- 0 changing the parameter has no effect on the resistance
- + by increasing the parameter the resistance also increases
- 0/+ depending on the anchor type
- +** Main parameter

- a) for bonded anchors: +
- b) with and without lever arm
- c) in case of tension forces due to bending, modifying the length and/or width of the fixture affects the lever arm and therefore the tension load acting on the anchors (the resistance is not affected)
- d) only anchors closest to the edge are considered according ETAG Annex C and EOTA Technical Report TR 029

OK, WHAT ABOUT STEEL FAILURE?

Eng. Aca. Optim. Start (Engineering Academy) - Sweden, European design (EN, ETAG), EN1992-4 Chemical, ETA 11,0493

BASE MATERIAL

- Cracked concrete
- C20/25
- $f_{c,cr}$: 20 N/mm²
- $f_{c,calc}$: 25 N/mm²

ANCHOR

- Family: HIT-HY 200 + HAS-U
- Type: HIT-HY 200 + HAS-U 5.8
- Size: M10
- View ETA approval
- Insert item #: 2223709 HAS-U 5.8 M10x170
- Mortar item #: 2022896 HIT-HY 200-A
- Embedment depth h_{ef} : 100 mm

CONCRETE REINFORCEMENT

- Concrete: Wide
- Edge: None
- Reinforcement to control cracking present:

SUPPLEMENTARY REINFORCEMENT

- Select reinforcement to prevent concrete breakout:
- No supplementary reinforcement

ANCHOR

- Calculate all
- HST3
- HST2
- HIT-HY 200 + HIT-Z 100 Years
- HIT-HY 200 + HAS-U
- HIT-HY 200 + AM
- HIT-HY 200 + HIS-N
- HIT-HY 200 + HAS-D
- HIT-HY 200 + HAS-U 100 Years
- HIT-HY 200 + AM 100 Years
- HIT-HY 200-R
- Type: HIT-HY 200 + HAS-U 5.8
- Size: M10
- View ETA approval
- Insert item #: 2223709 HAS-U 5.8 M10x170
- Mortar item #: 2022896 HIT-HY 200-A
- Embedment depth h_{ef} : 100 mm
- Design loads: Sustained loads

Generate report

ANCHOR LOADS

Anchor	N (kN)	Vx (kN)	Vy (kN)
1	32,109	2,5	2,5
2	32,109	2,5	2,5
3	1,849	2,5	2,5
4	1,849	2,5	2,5

ANCHOR DESIGN

Tension

- Steel: 167%
- Concrete breakout: 213%
- Bond: 274%
- Splitting: 0%

Shear

- Steel: 31%
- Concrete edge breakout: 63%
- Pryout: 21%

Combination

- Steel: 286%

NOTIFICATIONS

- Want to know how much anchor and mortar you need to order? Send the design to quantity calculator
- The anchor calculation is based on a rigid baseplate assumption.
- Smart Baseplate Selector: Your current design requirements do

N°	Name	Type	Loads			Forces [kN]			Moments [kNm]			Utilisation			
			Vx	Vy	N	Mx	My	Mz	T	S	C	Total			
1	Combination 1	Design	10	10	10	-10	0	0	274%	63%	286%	286%			
			Sustained			0	0	0							

LET US START BY TAKING CARE OF STEEL FAILURE BY

- Changing the steel grade to 8.8
- Changing the diameter to M12

OK, WHAT ABOUT BOND FAILURE?

PROFIS ENGINEERING Eng. Aca. Optim. Start (Engineering Academy) - Sweden, European design (EN, ETAG), EN1992-4 Chemical, ETA 11,0493

PROFILE

- Use profile:
- I profile:
- Height: 200 mm, Width: 90 mm
- Flange thickness: 11,3 mm, Thickness: 11,3 mm

ECCENTRICITY

- X-direction: 0 mm, Y-direction: 0 mm
- Angle: 270°, Rotation:

ANCHOR

- HST3
- HST2
- HIT-HY 200 + HIT-Z 100 Years
- HIT-HY 200 + HAS-U
- HIT-HY 200 + AM
- HIT-HY 200 + HIS-N
- HIT-HY 200 + HAS-D
- HIT-HY 200 + HAS-U 100 Years
- HIT-HY 200 + AM 100 Years
- HIT-HY 200-R
- HIT-HY 200 + HAS-U 8.8** (circled in red)

Size: M12

Embedment depth h_{ef} : 100 mm

ANCHOR LOADS

Anchor	N (kN)	Vx (kN)	Vy (kN)
1	32,583	2,5	2,5
2	32,583	2,5	2,5
3	0,774	2,5	2,5
4	0,774	2,5	2,5

ANCHOR DESIGN

Tension

- Steel: 73%
- Concrete breakout: 214%
- Bond: 222%**
- Splitting: 0%

Shear

- Steel: 14%
- Concrete edge breakout: 61%
- Pryout: 17%

Combination

- Concrete: 236%

UTILIZATION TABLE

N°	Name	Type	Forces [kN]			Moments [kNm]			Utilisation			
			Vx	Vy	N	Mx	My	Mz	T	S	C	Total
1	Combination 1	Design	10	10	10	-10	0	0	222%	61%	236%	236%
		Sustained			0	0	0					

LET US TAKE CARE OF BOND FAILURE BY

- Changing the embedment depth to 240 mm

OK, WHAT ABOUT CONCRETE BREAKOUT?

PROFIS ENGINEERING | Eng. Aca. Optim. Start (Engineering Academy) - Sweden, European design (EN, ETAG), EH1992-4 Chemical, ETA 11/0493

PROFILE

- Use profile:
- Profile: I profile
- Height: 200 mm, Width: 90 mm
- Flange thickness: 11,3 mm, Thickness: 11,3 mm
- Profile: I 200

ECCENTRICITY

- X-direction: 0 mm, Y-direction: 0 mm
- Angle: 270°, Rotation:

ANCHOR

- Calculate all
- HST3, HST2, HIT-HY 200 + HIT-Z 100 Years, HIT-HY 200 + HAS-U, HIT-HY 200 + AM, HIT-HY 200 + HIS-N, HIT-HY 200 + HAS-D (New), HIT-HY 200 + HAS-U 100 Years (New), HIT-HY 200 + AM 100 Years (New), HIT-HY 200-R
- Type: HIT-HY 200 + HAS-U 8.8
- Size: M12
- View ETA approval
- Insert item #: 2223883 HAS-U 8.8 M12x300
- Mortar item #: 2022696 HIT-HY 200-A
- Embedment depth h_{ef} : 240 mm
- Design load: Sustained loads

ANCHOR LOADS

Anchor	N (kN)	Vx (kN)	Vy (kN)
1	32,583	2,5	2,5
2	32,583	2,5	2,5
3	0,774	2,5	2,5
4	0,774	2,5	2,5

ANCHOR DESIGN

Tension

- Steel: 73%
- Concrete breakout: 110% ⊕
- Bond: 96%
- Splitting: 103% ⊕

Shear

- Steel: 14%
- Concrete edge breakout: 58%
- Pryout: 10%

Combination

- Concrete: 139% ⊕

NOTIFICATIONS

- Want to know how much anchor and mortar you need to order? [Send the design to quantity calculator](#)
- You can attempt to find a solution by adjusting the connection geometry. [Find solution](#)

N°	Name	Type	Loads	Forces [kN]			Moments [kNm]			Utilisation			
				Vx	Vy	N	Mx	My	Mz	T	S	C	Total
1	Combination 1	+	Design	10	10	10	-10	0	0	110%	58%	139%	139%
			Sustained			0	0	0					

LET US TAKE CARE OF CONCRETE BREAKOUT BY

- Enlarging the baseplate to 250 x 250 mm
- Putting the anchors to 200 x 200 mm

OK, WHAT ABOUT COMB. CONCRETE FAILURE?

HILTI PROFIS ENGINEERING Eng. Aca. Optim. Start (Engineering Academy) - Sweden, European design (EN, ETAG), EN1992-4 Chemical, ETA 11/0493

PROFILE

Use profile

I profile

Height: 200 mm, Width: 90 mm

Flange thickness: 11,3 mm, Thickness: 11,3 mm

I 200

ECCENTRICITY

X-direction: 0 mm, Y-direction: 0 mm

Angle: 270°, Rotation:

ANCHOR

Calculate all

- HST3
- HST2
- HIT-HY 200 + HIT-Z 100 Years
- HIT-HY 200 + HAS-U
- HIT-HY 200 + AM
- HIT-HY 200 + HIS-N
- HIT-HY 200 + HAS-D (New)
- HIT-HY 200 + HAS-U 100 Years (New)
- HIT-HY 200 + AM 100 Years (New)
- HIT-HY 200-R

Type: HIT-HY 200 + HAS-U 8.8

Size: M12

View ETA approval

Insert item #: 2223883 HAS-U 8.8 M12x300

Mortar item #: 2022696 HIT-HY 200-A

Embedment depth h_{ef}: 240 mm

Design loads / Sustained loads

Generate report

ANCHOR LOADS

Anchor	N (kN)	Vx (kN)	Vy (kN)
1	26,187	2,5	2,5
2	26,187	2,5	2,5
3	0	2,5	2,5
4	0	2,5	2,5

ANCHOR DESIGN

Tension

- Steel: 59%
- Concrete breakout: 86%
- Bond: 86%
- Splitting: 87%

Shear

- Steel: 14%
- Concrete edge breakout: 66%
- Pryout: 10%

Combination

- Concrete: 127%

NOTIFICATIONS

Want to know how much anchor and mortar you need to order? Send the design to quantity calculator

You can attempt to find a solution by adjusting the connection geometry. Find solution

N°	Name	Type	Loads	Forces [kN]			Moments [kNm]			Utilisation			
				Vx	Vy	N	Mx	My	Mz	T	S	C	Total
1	Combination 1		Design	10	10	10	-10	0	0	87%	66%	127%	127%
			Sustained			0	0	0					

LET US TAKE CARE OF COMB. CONCRETE FAILURE BY

- Enlarging the baseplate (in y direction) to 600 mm to get longer inner lever arm leading to smaller loads in anchors

OK, WHAT ABOUT CONCRETE BREAKOUT?

BASE MATERIAL

- Cracked concrete
- C20/25
- $f_{c,cr}$: 20 N/mm²
- $f_{c,cube}$: 25 N/mm²

ANCHOR

- Family: HIT-HY 200 + HAS-U
- Type: HIT-HY 200 + HAS-U 8.8
- Size: M12
- Embedment depth h_{ef} : 240 mm

CONCRETE REINFORCEMENT

- Concrete: Wide
- Edge: None
- Reinforcement to control cracking present:

SUPPLEMENTARY REINFORCEMENT

- Select reinforcement to prevent concrete breakout:
- No supplementary reinforcement

ANCHOR LOADS

Anchor	Nx (kN)	Ny (kN)	Vy (kN)
1	14,061	2,5	2,5
2	14,061	2,5	2,5
3	5,828	2,5	2,5
4	5,828	2,5	2,5

ANCHOR DESIGN

Tension

- Steel: 32%
- Concrete breakout: 57%
- Bond: 48%
- Splitting: 55%

Shear

- Concrete edge breakout: 66%

Combination

- Concrete: 96%

NOTIFICATIONS

- Want to know how much anchor and mortar you need to order? [Send the design to quantity calculator](#)
- You can improve your design by optimising the layout of your anchors. [Optimise](#)
- You can improve your design by optimising the baseplate geometry. [Optimise](#)

Table: Design and Sustained Loads

N°	Name	Type	Loads			Forces [kN]			Moments [kNm]			Utilisation			
			Vx	Vy	N	Mx	My	Mz	T	S	C	Total			
1	Combination 1	Design	10	10	10	-10	0	0	57%	66%	96%	96%			
		Sustained			0	0	0								

LET US BECAUSE OF LOW UTILIZATION IN STEEL FAILURE

- Changing to 2 anchors only
- Adjust baseplate to 400 x 120 mm
- Adjust anchors to 350 mm

WE HAVE A SOLUTION!

HILTI PROFIS ENGINEERING Eng. Aca. Optim. Start (Engineering Academy) - Sweden, European design (EN, ETAG), EN1992-4 Chemical, ETA 11/0493

ANCHOR

Family: HIT-HY 200 + HAS-U

Type: HIT-HY 200 + HAS-U 8.8

Size: M12

View ETA approval

Insert item #: 2223883 HAS-U 8.8 M12x300

Mortar item #: 2022696 HIT-HY 200-A

Embedment depth h_{ef}: 240 mm

LAYOUT

Rotation: 0°

INSTALLATION

Fill holes

ANCHOR

Anchor	N (kN)	Vx (kN)	Vy (kN)
1	32,967	5	5
2	0	5	5

ANCHOR DESIGN

Tension

- Steel: 74%
- Concrete breakout: 58%
- Bond: 65%
- Splitting: 49%

Shear

- Concrete edge breakout: 31%

Combination

- Concrete: 69%

NOTIFICATIONS

- Want to know how much anchor and mortar you need to order? Send the design to quantity calculator.
- You can improve your design by optimising the layout of your anchors. Optimise
- You can improve your design by optimising the baseplate geometry. Optimise

N°	Name	Type	Loads	Forces [kN]			Moments [kNm]			Utilisation			
				Vx	Vy	N	Mx	My	Mz	T	S	C	Total
1	Combination 1		Design	10	10	10	-10	0	0	74%	31%	69%	74%
			Sustained			0	0	0					

OK, BUT IS THE BASEPLATE SUFFICIENTLY RIGID?

The screenshot displays the HILTI PROFIS ENGINEERING software interface. The central 3D model shows a baseplate with dimensions: 200x200 mm footprint, 400 mm length, 500 mm width, and 120 mm height. Two anchors are positioned 60 mm from the left edge and 25 mm from the bottom edge. A table at the bottom summarizes the design data for 'Combination 1'.

N°	Name	Type	Loads	Forces [kN]			Moments [kNm]			Utilisation			
				Vx	Vy	N	Mx	My	Mz	T	S	C	Total
1	Combination 1		Design	10	10	10	-10	0	0	74%	31%	69%	74%
			Sustained			0	0	0					

OK, BUT IS THE BASEPLATE SUFFICIENTLY RIGID?

- The linear strain distribution is valid if the fixture is **sufficiently rigid**, the baseplate remains elastic under design actions and its deformation remains negligible.

Key

$$N_{Ed,i} = \varepsilon_{s,i} \cdot E_s \cdot A_s$$

$$C_{Ed} = 0,5 \cdot b_{fix} \cdot x \cdot \varepsilon_c \cdot E_c$$

**ACCORDING TO LINEAR LOAD DISTRIBUTION
THE TENSION LOAD IN ANCHOR 1 IS: 32,967 kN
=> 33,0 kN**

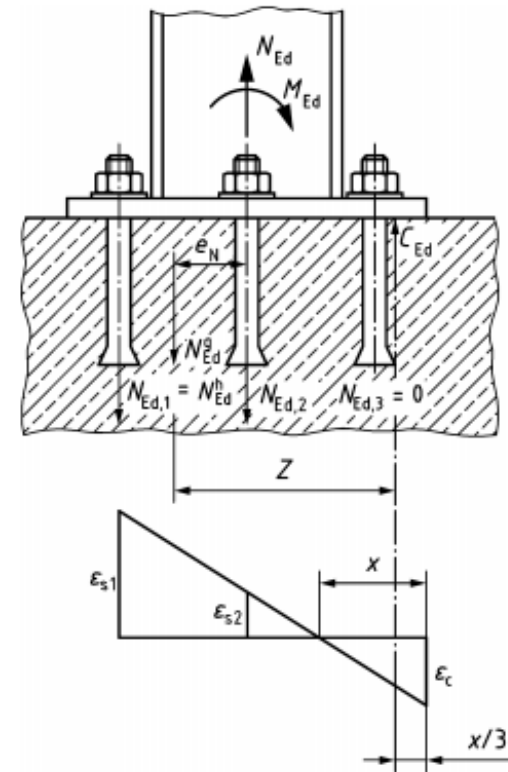

AGENDA

- Design of Fasteners For Use In Concrete According to EN 1992-4
- Design Your Baseplate With PROFIS Engineering – Assuming a Rigid Baseplate
- **Design Your Baseplate With PROFIS Engineering – Using CBFEM**
- Questions & Answers

EQUIVALENT RIGID BASEPLATE CALC. USE THE REAL STIFFNESS IN THE ANCHOR, HIT-HY 200 + HAS-U 8.8 M12 => 33,6 KN

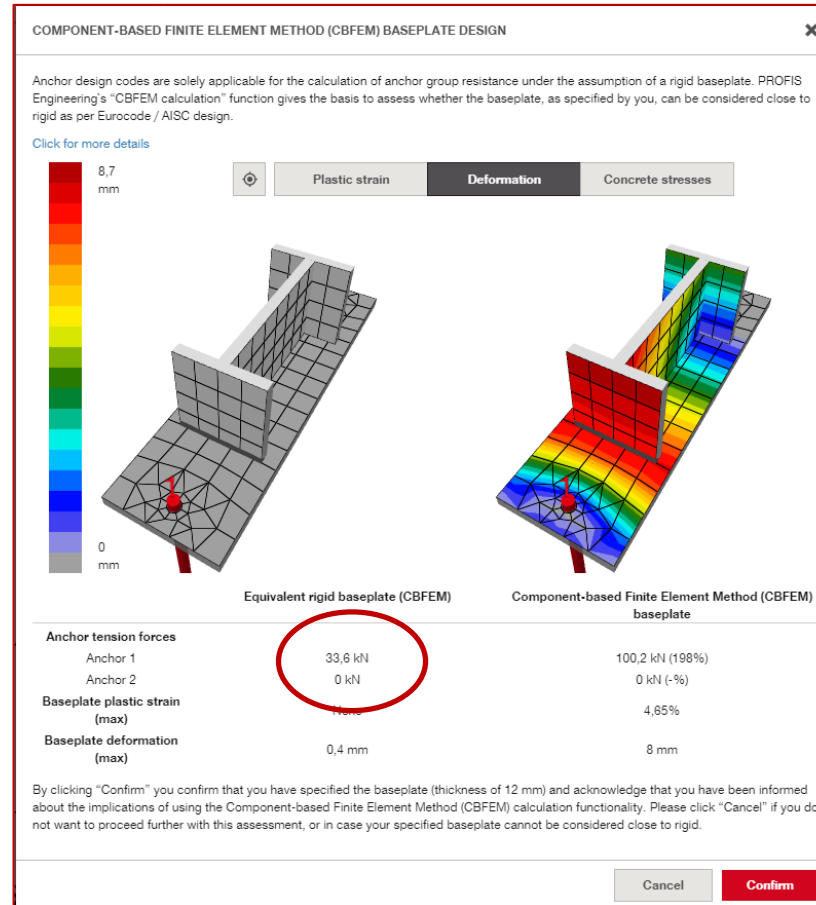

EQUIVALENT RIGID BASEPLATE CALC. USE THE REAL STIFFNESS IN THE ANCHOR, HVZ M12 X 95 => 33,8 KN

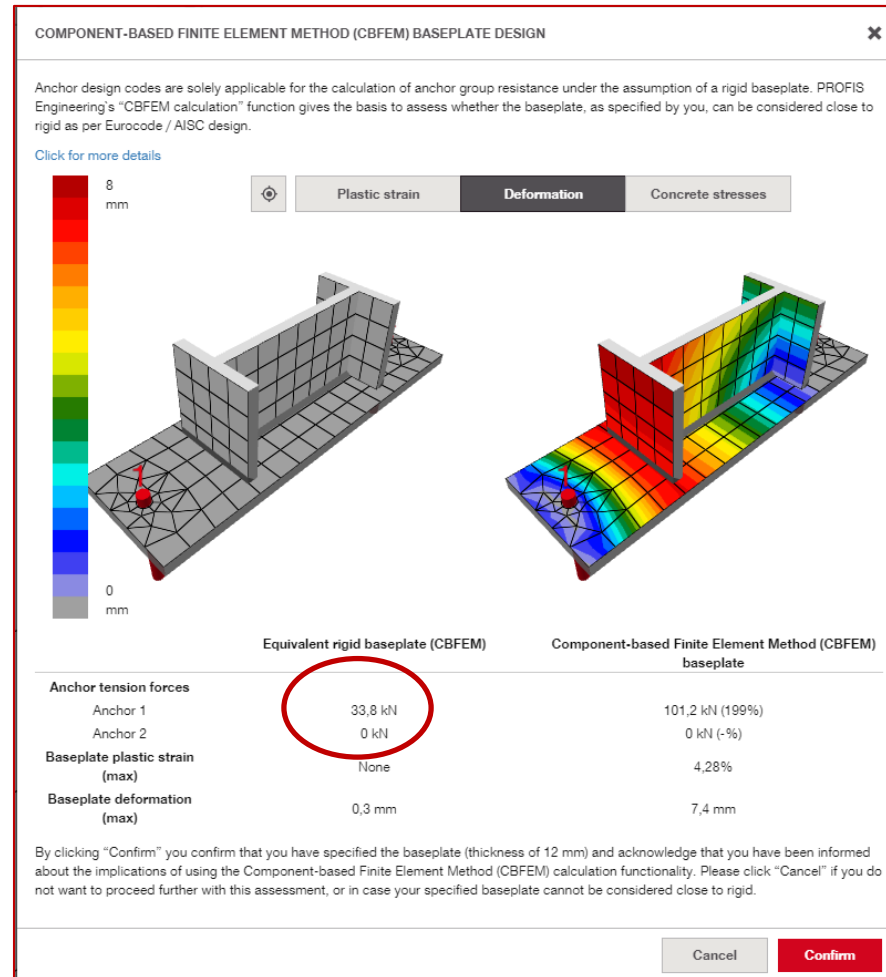

EQUIVALENT RIGID BASEPLATE CALC. USE THE REAL STIFFNESS IN THE ANCHOR, HST3 M12 X 115 => 33,1 KN

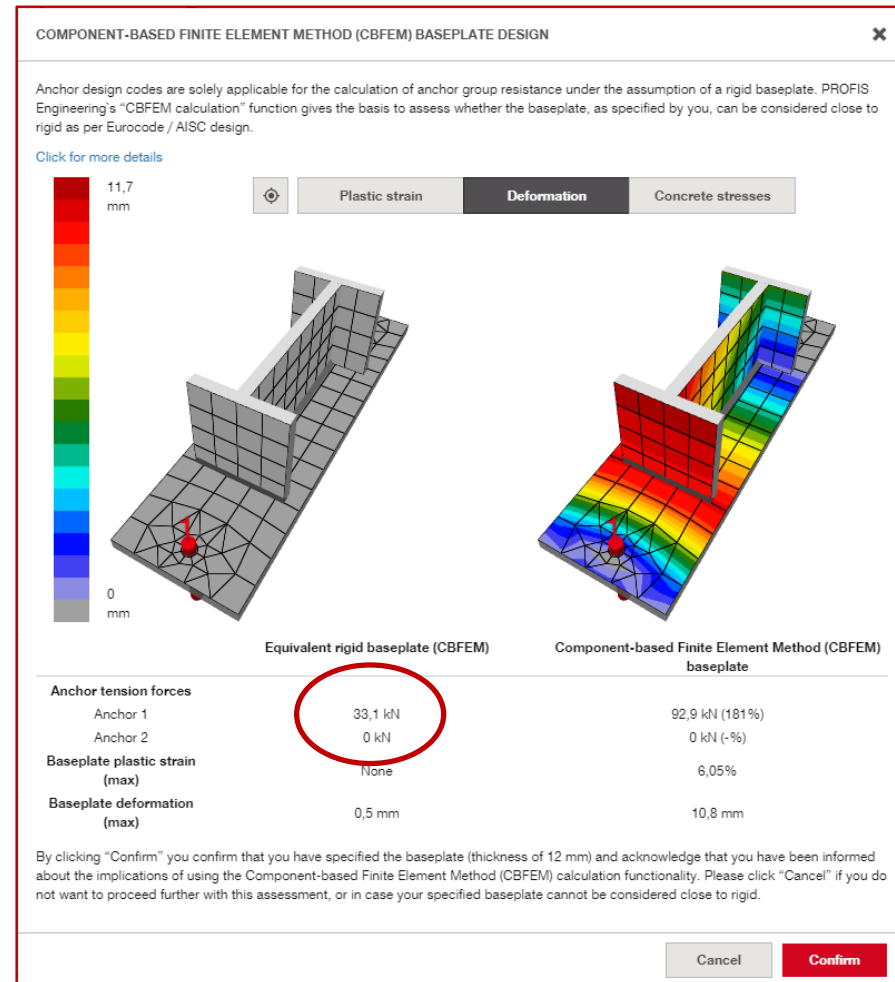

CBFEM – REAL LOAD AND DEFORMATIONS!

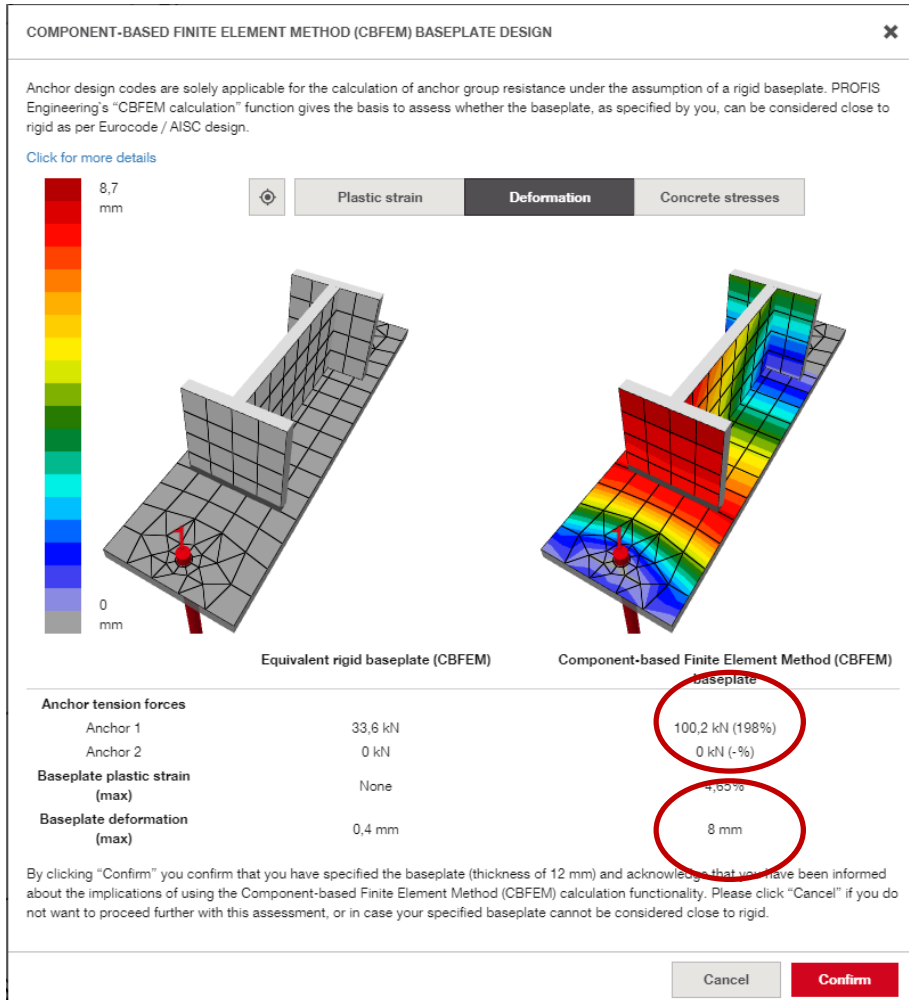

- Checking rigidity by comparing tension load in CBFEM to Equivalent rigid. < 10 % is the Hilti definition of close to rigid.
- Checking baseplate deformation. What is a negligible deformation?
- Checking stress and plastic strain in baseplate.
- Checking stress and plastic strain in profile.
- Checking stress in welds.
- Checking compression in concrete.
- Checking the anchors.

HOW TO MAKE THE FIXINGPOINT SUFFICIENTLY RIGID?

- Increase baseplate thickness
- Add stiffeners
- Relocate anchors closer to profile
- Reduce baseplate overhang size
- Change anchors
- Increase profile size

1. INCREASE BASEPLATE THICKNESS TO 20 MM

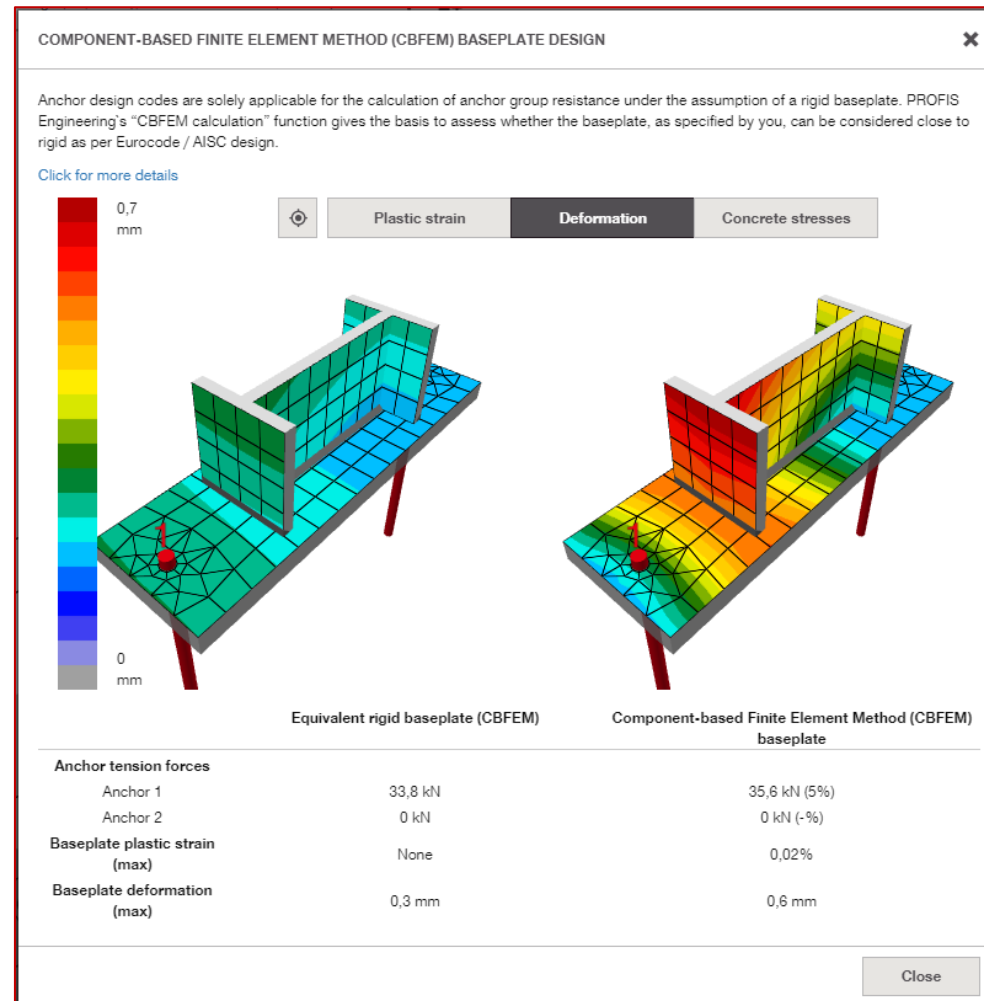

2. INCREASE BASEPLATE THICKNESS TO 15 MM AND ADD STIFFENERS

COMPONENT-BASED FINITE ELEMENT METHOD (CBFEM) BASEPLATE DESIGN

Anchor design codes are solely applicable for the calculation of anchor group resistance under the assumption of a rigid baseplate. PROFIS Engineering's "CBFEM calculation" function gives the basis to assess whether the baseplate, as specified by you, can be considered close to rigid as per Eurocode / AISC design.

[Click for more details](#)

0,7 mm

0 mm

Plastic strain Deformation Concrete stresses

	Equivalent rigid baseplate (CBFEM)	Component-based Finite Element Method (CBFEM) baseplate
Anchor tension forces		
Anchor 1	33,7 kN	35,1 kN (4%)
Anchor 2	0 kN	0 kN (-%)
Baseplate plastic strain (max)	None	0,02%
Baseplate deformation (max)	0,3 mm	0,5 mm

By clicking "Confirm" you confirm that you have specified the baseplate (thickness of 15 mm) and acknowledge that you have been informed about the implications of using the Component-based Finite Element Method (CBFEM) calculation functionality. Please click "Cancel" if you do not want to proceed further with this assessment, or in case your specified baseplate cannot be considered close to rigid.

Cancel Confirm

3. INCREASE BASEPLATE THICKNESS TO 15 MM, RELOCATE ANCHORS CLOSER TO PROFILE, REDUCE LENGTH OF BASEPLATE TO 330 MM & CHANGE ANCHOR SIZE TO M16

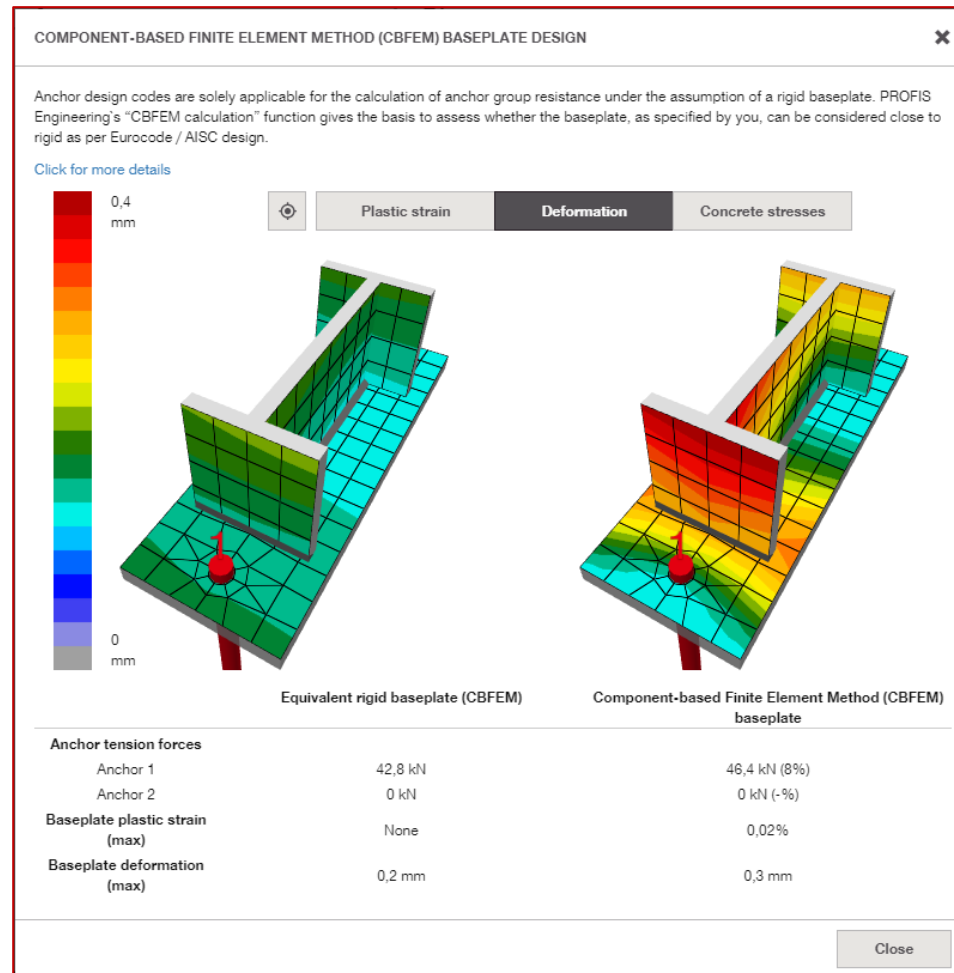

WE HAVE A FINAL SOLUTION!



Hilti PROFIS Engineering 3.0.69

www.hilti.se

Company: Hilti Svenska AB
Address: Testvägen 1, 232 22 Arlööv
Phone | Fax: +46702347553 |
Design: Eng. Aca. Optim. Start
Fastening Point:

Page: 1
Specifier: Rickard Bergeryd
E-Mail: rickard.bergeryd@hilti.com
Date: 5/24/2021

Specifier's comments:

1 Anchor Design

1.1 Input data

Anchor type and size:	HIT-HY 200 + HAS-U 8.8 M16	
Return period (service life in years):	50	
Item number:	2223884 HAS-U 8.8 M16x300 (insert) / 2022696 HIT-HY 200-A (mortar)	
Effective embedment depth:	$h_{ef,calc} = 240.0$ mm ($h_{ef,req} = -$ mm)	
Material:	8.8	
Approval No.:	ETA 11/0493	
Issued Valid:	12/14/2020 -	
Proof:	Design Method EN 1992-4, Chemical	
Stand-off installation:	$e_n = 0.0$ mm (no stand-off), $t = 15.0$ mm	
Baseplate ^{CBFEM} :	$l_y \times l_x = 120.0$ mm x 330.0 mm x 15.0 mm;	
Profile:	I profile, I 200; (L x W x T x FT) = 200.0 mm x 90.0 mm x 11.3 mm x 11.3 mm	
Base material:	cracked concrete, C20/25, $f_{ct,cr} = 20.00$ N/mm ² , $h = 500.0$ mm, Temp. short/long: 40/24 °C, User-defined partial material safety factor $\gamma_c = 1.500$	
Installation:	hammer drilled hole, Installation condition: Dry	
Reinforcement:	No reinforcement or Reinforcement spacing ≥ 150 mm (any \emptyset) or ≥ 100 mm ($\emptyset \leq 10$ mm) no longitudinal edge reinforcement	

^{CBFEM} - The anchor calculation is based on a component-based Finite Element Method (CBFEM)

Geometry [mm] & Loading [kN, kNm]

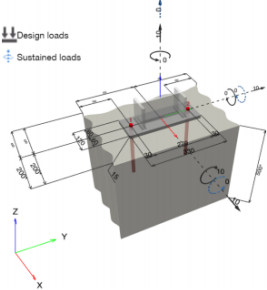

Input data and results must be checked for conformity with the existing conditions and for plausibility!
PROFIS Engineering (c) 2003-2021 Hilti AG, FL-9494 Schaan. Hilti is a registered Trademark of Hilti AG, Schaan

1

EN 1992-4 DESIGN OF FASTENINGS FOR USE IN CONCRETE

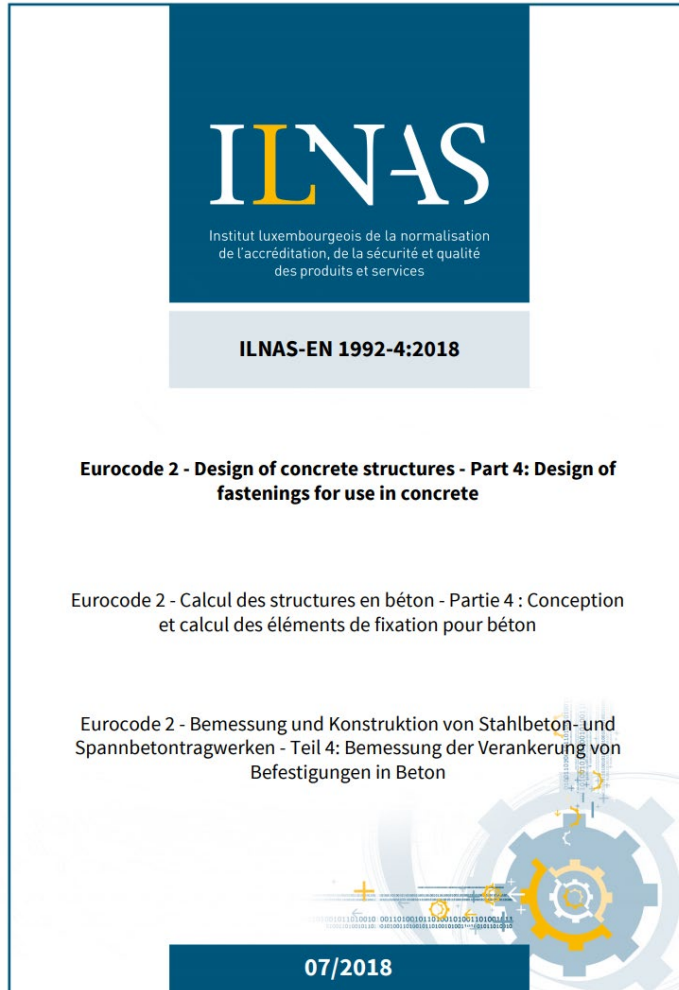

- A specification shall typically include manufacturer, type and geometry of the fasteners. **Fastenings shall no be changed unless verified and approved by the responsible designer.** (EN 1992-4:2018; 4.5)

- Always assume that the **concrete is cracked** over its service life unless you can prove the opposite. (EN 1992-4:2018; 4.7)

- The linear strain distribution is valid if the fixture is **sufficiently rigid**, the baseplate remains elastic under design actions and its deformation remains negligible. (EN 1992-4:2018; 6.2.1)

Key

$$N_{Ed, i} = \varepsilon_{s, i} \cdot E_s \cdot A_s$$

$$C_{Ed} = 0,5 \cdot b_{fix} \cdot x \cdot \varepsilon_c \cdot E_c$$

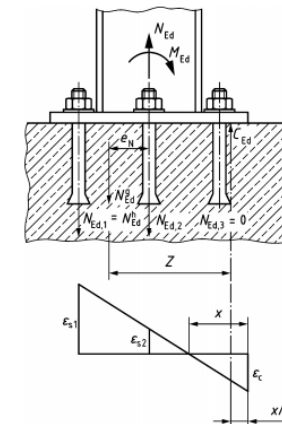

CBFEM – REAL LOAD AND DEFORMATIONS!

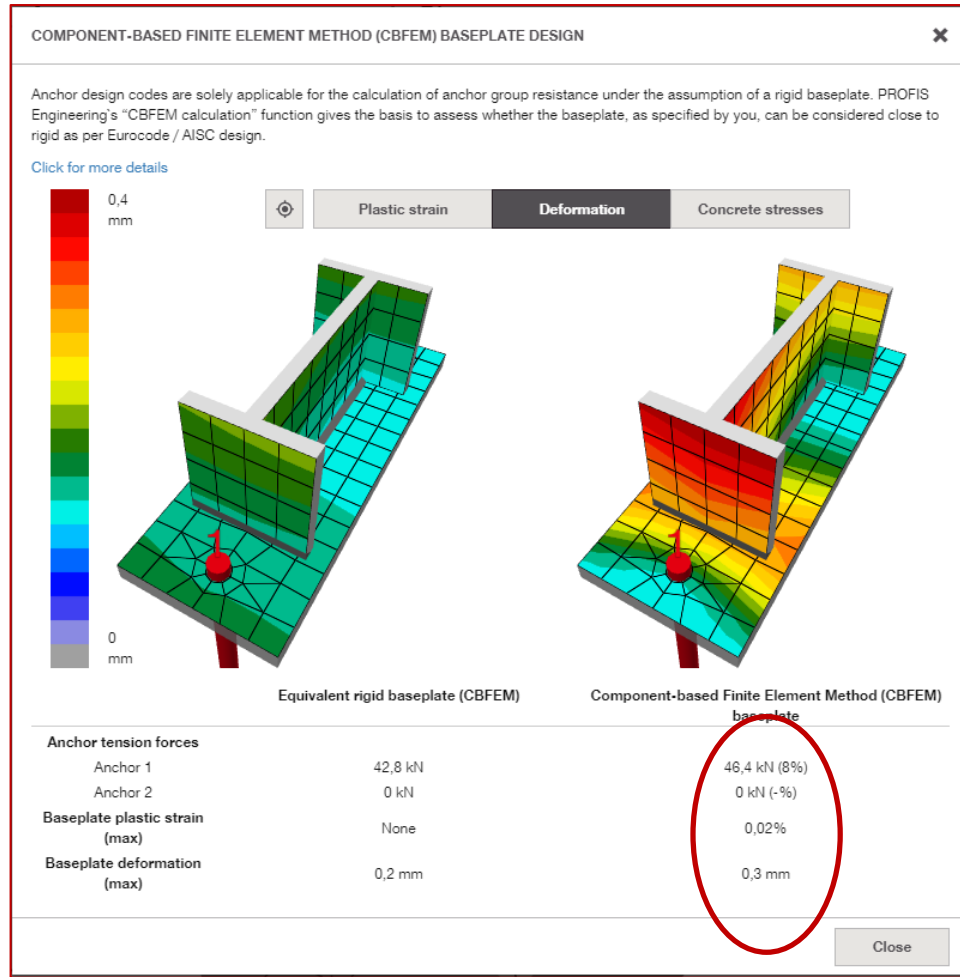

- Checking rigidity by comparing tension load in CBFEM to Equivalent rigid. $< 10\%$ is the Hilti definition of close to rigid. **It is your judgement as designer in the end!**
- Checking baseplate deformation. What is a negligible deformation? **It is your judgement as designer in the end!**
- Checking stress and plastic strain in baseplate.
- Checking stress and plastic strain in profile.
- Checking stress in welds.
- Checking compression in concrete.
- Checking the anchors.

AGENDA

- Design of Fasteners For Use In Concrete According to EN 1992-4
- Design Your Baseplate With PROFIS Engineering – Assuming a Rigid Baseplate
- Design Your Baseplate With PROFIS Engineering – Using CBFEM
- **Questions & Answers**

QUESTIONS AND ANSWERS





<https://ask.hilti.co.uk/series>

THANK YOU FOR
PARTICIPATING AT THE
WEBINAR!

Rickard Bergeryd
Anchor Expert
Carlos Taborda
Technical Marketing Manager
May 25, 2021

