



HIT-1 ADHESIVE ANCHORING SYSTEM

Technical Supplement

PRODUCT DESCRIPTION

Hilti HIT-1 is a hybrid adhesive mortar combining resin, hardener, cement, and water. It's formulated for fast curing and easy installation in a wide range of concrete and masonry base materials with temperatures ranging from 32°F (0°C) up to 95°F (35°C). HIT-1 is styrene-free and virtually odorless.

HIT-1 Adhesive anchor system is easy-to-use and has numerous applications. The system consists of a cartridge which fits any standard caulk gun, a mixing nozzle which comes with every cartridge, and a threaded rod. HIT-1 is designed for fastenings into solid base materials such as concrete and grout-filled block, and is suitable for fastenings into base materials containing voids and holes such as hollow concrete masonry units and brick with holes when used with a screen tube.

Features

- For use with standard caulk gun
- For many base materials
- Easy-to-use

Benefits

- No additional equipment needed — start working right away
- Good performance from one product for many applications
- Open cartridges may be stored for up to 4 weeks by leaving the mixer attached
- Low dispensing forces. Optional high quality Hilti MD 300 dispenser available.

Fastener Components

Solid Base Material — Concrete and Grout Filled Block



HAS or HIT-V threading rod

Hollow Base Material — Hollow Block and Brick



HAS or HIT-V threading rod

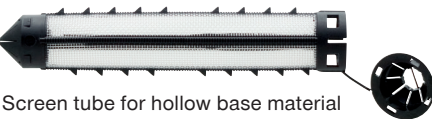

Screen tube for hollow base material



MD 300 dispenser



Standard caulk gun



HIT PM Mixer

HIT-1 Cartridge

TECHNICAL DATA

This document is a supplement to the Hilti North American Product Technical Guide, Volume 2: Anchor Fastening, Edition 17. For additional information including data development, general suitability, installation, corrosion, and spacing and edge distance guidelines, visit www.hilti.com or www.hilti.ca for the full document.

Figure 1 — HIT-1 in concrete and grout-filled concrete masonry (see Table 1)

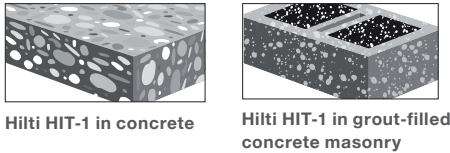

HAS / HIT-V

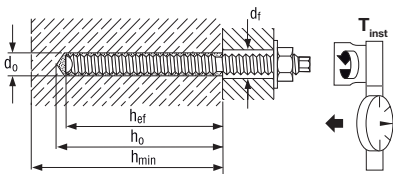
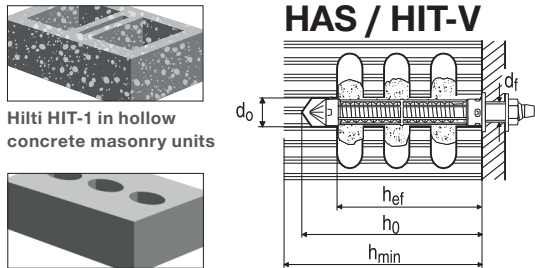

Figure 2 — HIT-1 in hollow concrete masonry and brick with holes (see Table 2)



Hilti HIT-1 in brick with holes

Table 1 — HIT-1 installation parameters in concrete and grout-filled concrete masonry units

Design parameter	Symbol	Units	Nominal rod diameter (in.)		
			3/8	1/2	5/8
Drill bit diameter	d_o	in	7/16	9/16	11/16
Minimum hole depth	h_o	in (mm)	3-5/8 (92)	4-3/4 (121)	6-1/8 (156)
Effective embedment depth	h_{ef}	in (mm)	3-3/8 (86)	4-1/2 (114)	5-5/8 (143)
Min. concrete thickness	h_{min}	in (mm)	4-5/8 (117)	5-3/4 (146)	7-3/4 (197)
Installation torque	T_{inst}	ft-lb (Nm)	15 (20)	30 (40)	45 (60)

Table 2 — HIT-1 installation parameters in hollow concrete masonry units and brick with holes

	Symbol	Units	Hollow Concrete Masonry Units				Brick with Holes			
			Nominal rod diameter (in.)				Nominal rod diameter (in.)			
			1/4	5/16	3/8	1/2	1/4	5/16	3/8	1/2
Drill bit diameter	d_o	in.	1/2	5/8	5/8	11/16	1/2	5/8	5/8	11/16
Minimum hole depth	h_o	in. (mm)	Drill through face shell				2-3/8 (60)	3-3/8 (86)		
Effective embedment depth	h_{ef}	in. (mm)	2 (50)				2 (50)	3-1/8 (80)		
Installation torque	T_{inst}	ft-lb (Nm)	Finger Tight	2.2 (3)	3 (4.5)	4-1/2 (6)	Finger Tight	2 (3)	3 (4)	5 (6)
Screen Tube Size	—	—	HIT-SC 12x50	HIT-SC 16x50	HIT-SC 16x50	HIT-SC 18x50	HIT-SC 12x85	HIT-SC 16x85	HIT-SC 16x85	HIT-SC 18x85

Table 3 — Allowable steel strength for Hilti HIT-V and HAS threaded rods^{1,2}

Nominal Anchor Diameter in.	HIT-V ASTM A307 Grade A ²		HAS-E ISO 898 Class 5.8 ²		HAS-E B7 ASTM A193 B7		HAS-R Stainless Steel ASTM F 593 — AISI 304/316 SS	
	Tensile lb (kN)	Shear lb (kN)	Tensile lb (kN)	Shear lb (kN)	Tensile lb (kN)	Shear lb (kN)	Tensile lb (kN)	Shear lb (kN)
3/8	2,185 (9.7)	1,125 (5.0)	2,640 (11.7)	1,360 (6.0)	4,555 (20.3)	2,345 (10.4)	3,645 (16.2)	1,875 (8.3)
1/2	3,885 (17.3)	2,000 (8.9)	4,700 (20.9)	2,420 (10.8)	8,100 (36.0)	4,170 (18.5)	6,480 (28.8)	3,335 (14.8)
5/8	6,075 (27.0)	3,130 (13.9)	7,340 (32.6)	3,780 (16.8)	12,655 (56.3)	6,520 (29.0)	10,125 (45.0)	5,215 (23.2)

- Steel strength as defined in AISC Manual of Steel Construction (ASD):
Tensile = 0.33 X F_u X Nominal Area
Shear = 0.17 X F_u X Nominal Area.
- HIT-V and HAS-E do not comply with % elongation requirements of ASTM A 307 Grade A and ISO 898-1 specifications and are considered a brittle element.

Table 4 — Hilti HIT-1 adhesive allowable loads for concrete/bond failure for fractional threaded rod in uncracked concrete^{1,2,3,4,5,6,7,8,9}

Nominal Anchor in.	Effective embedment in. (mm)	Allowable Tension Loads			Allowable Shear Loads		
		f' _c = 2500 psi (17.2 Mpa) lb (kN)	f' _c = 3000 psi (20.7 Mpa) lb (kN)	f' _c = 4000 psi (27.6 Mpa) lb (kN)	f' _c = 2500 psi (17.2 Mpa) lb (kN)	f' _c = 3000 psi (20.7 Mpa) lb (kN)	f' _c = 4000 psi (27.6 Mpa) lb (kN)
3/8	3–3/8 (86)	1,600 (7.1)	1,665 (7.4)	1,775 (7.9)	3,830 (17.0)	3,985 (17.7)	4,245 (18.9)
1/2	4–1/2 (114)	2,330 (10.4)	2,425 (10.8)	2,580 (11.5)	6,585 (29.3)	6,855 (30.5)	7,300 (32.5)
5/8	5–5/8 (143)	3,015 (13.4)	3,140 (14.0)	3,345 (14.9)	7,215 (32.1)	7,510 (33.4)	8,000 (35.6)

- Use lower value of either bond/concrete capacity or steel strength of bolt used.
- See Section 3.1.8 of the North American Volume 2: Anchor Product Technical Guide for explanation on development of load values.
- Linear interpolation between embedment depths and concrete compressive strengths is not permitted.
- Minimum anchor spacing, s_{min} = 3 X h_{ef}, h_{ef} is the anchor embedment depth.
- Values are for the following temperature range: maximum short term temperature = 120°F (50°C), maximum long term temperature = 120°F (50°C). Short term elevated concrete temperatures are those that occur over brief intervals, e.g., as a result of diurnal cycling. Long term concrete temperatures are over significant periods of time.
- Tabular values are for dry concrete conditions. Use in water saturated concrete is not permitted.
- Tabular values are for short term loads only. For sustained loads including overhead use, see Section 3.1.8.8 of the North American Volume 2: Anchor Fastening Technical Guide.
- Tabular values are for normal-weight concrete only. For lightweight concrete multiply allowable load by λ_a as follows:
For sand-lightweight, λ_a = 0.45.
- Tabular values are for holes drilled in concrete with carbide tipped hammer drill bit. Diamond core drilling is not permitted.

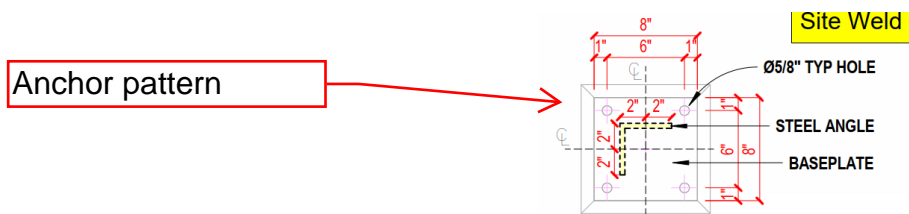
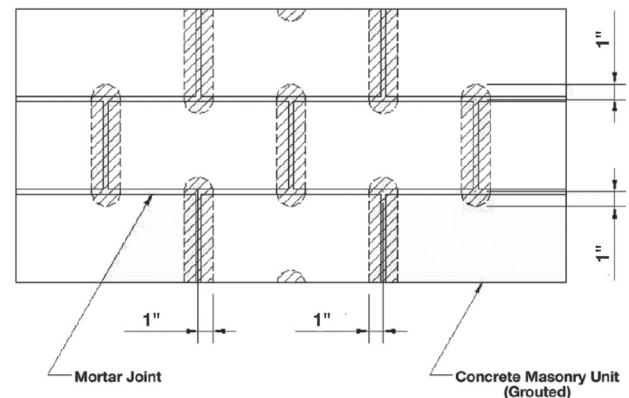

Table 5 — HIT-1 allowable bond/CMU block capacity for threading rods in grout-filled concrete masonry units^{1,2,3,4,5,6,7,8}

Nominal Anchor in.	Embedded Depth in. (mm)	Distance from Edge		Allowable Bond/CMU Block Capacity				Ultimate Bond/CMU Block Capacity			
				Tension		Shear		Tension		Shear	
		in.	(mm)	lb	(kN)	lb	(kN)	lb	(kN)	lb	(kN)
3/8	3-3/8 (86)	4	(102)	825	(3.7)	1,065	(4.7)	3,300	(14.7)	4,255	(18.9)
		≥20	(508)	990	(4.0)	1,065	(4.7)	3,960	(15.8)	4,255	(18.9)
1/2	4-1/2 (108)	4	(102)	990	(4.4)	1,635	(7.3)	3,955	(17.6)	6,545	(21.1)
		≥20	(508)	1,585	(5.3)	1,755	(7.8)	6,340	(21.1)	7,015	(31.2)
5/8	5-5/8 (143)	4	(102)	1,285	(5.7)	1,990	(8.8)	5,140	(22.9)	7,950	(35.4)
		≥20	(508)	1,940	(7.7)	2,430	(10.8)	7,760	(30.9)	9,915	(43.2)

- Values are for lightweight, medium weight or normal weight concrete masonry units conforming to ASTM C 90 with 2000 psi grout conforming to ASTM C 476.
- Embedment depth is measured from the outside face of the concrete masonry unit.
- See Figure 3 for permissible locations to install anchors in the face of grout-filled CMU blocks.
- Values for edge distance between 4 inches and 20 inches can be calculated by linear interpolation.
- Allowable loads are based on a safety factor of 4 applied to the average ultimate test loads.
- Use lower value of either bond/CMU block capacity or steel strength of bolt used.
- Minimum anchor spacing, s_{min} = One (1) anchor per block cell, 8 inches min.
- Minimum edge distance c_{min} = 12 inches (305 mm) from free edge.

Figure 3 — Locations for HIT-1 in grout-filled CMU (anchor installation is restricted to non-shaded area)

Table 6 — HIT-1 allowable bond/masonry capacity for HAS/HIT-V threaded rods in hollow concrete masonry units, brick with holes^{1,2,3,5}

Nominal Anchor in.	L/W or N/W Hollow Concrete Block ³ Short 2-in. (51 mm) Embedment		Brick with Holes ⁴ Standard 3-3/4-in. (86 mm) Embedment	
	Tension lb (kN)	Shear lb (kN)	Tension lb (kN)	Shear lb (kN)
1/4	130 (0.6)	235 (1.0)	410 (1.8)	305 (1.4)
5/16	130 (0.6)	235 (1.0)	445 (2.0)	530 (2.4)
3/8	180 (0.8)	500 (2.2)	575 (2.6)	930 (4.1)
1/2	205 (0.9)	560 (2.5)	620 (2.8)	1375 (6.1)

- Based on using a safety factor of 6 for tension and 4 for shear applied to the average ultimate test loads.
- Values are for lightweight, medium weight or normal weight concrete masonry units conforming to ASTM C 90. Due to wide strength variations encountered in brick with holes, these values should be considered as guide values.
- Minimum anchor spacing, s_{min} = One (1) anchor per block cell, 8 inches min.
- Minimum anchor spacing, s_{min} = 8 inches min.
- Minimum edge distance c_{min} = 12 inches (305 mm) from free edge.