



## European Technical Assessment

**ETA-20/0541**  
**du 21/11/2020**

*English translation prepared by CSTB - Original version in French language*

### General Part

Nom commercial:  
*Trade name:*

**Injection system Hilti HIT-RE 500 V4**

Famille de produit:  
*Product family:*

Cheville à scellement avec tige filetée, fers à béton, douille taraudée HIS-(R)N et cheville de traction Hilti HZA(-R) pour usage dans le béton.

**Bonded fastener with threaded rods, rebar, internally threaded sleeve HIS-(R)N and Hilti tension anchor HZA(-R) for use in concrete.**

Titulaire:  
*Manufacturer:*

Hilti Corporation  
Feldkircherstrasse 100  
FL-9494 Schaan  
Principality of Liechtenstein

Usine de fabrication:  
*Manufacturing plants:*

Hilti Plant

Cette évaluation contient:  
*This Assessment contains:*

52 pages incluant 49 pages d'annexes qui font partie intégrante de cette évaluation  
*52 pages including 49 pages of annexes which form an integral part of this assessment*

Base de l'ETE:  
*Basis of ETA:*

EAD 330499-01-0601

Cette évaluation remplace:  
*This Assessment replaces:*

*Translations of this European Technical Assessment in other languages shall fully correspond to the original issued document and should be identified as such. Communication of this European Technical Assessment, including transmission by electronic means, shall be in full. However, partial reproduction may be made, with the written consent of the issuing Technical Assessment Body. Any partial reproduction has to be identified as such.*

## Specific Part

### 1 Technical description of the product

The Injection system Hilti HIT-RE 500 V4 is a bonded fastener consisting of a foil pack with injection mortar Hilti HIT-RE 500 V4 and a steel element.

These steel elements are:

- a threaded rod Hilti HAS-U, Hilti HIT-V, Hilti meter rod AM 8.8 or a commercial threaded rod with washer and hexagon nut in the range of M8 to M30
- a rebar in the range of  $\phi 8$  to  $\phi 32$
- a Hilti Tension Anchor HZA in the range of M12 to M27 or HZA-R in the range of M12 to M24.
- an internal threaded sleeve HIS-(R)N in the range M8 to M20

The steel element is placed into a drilled hole filled with injection mortar and is anchored via the bond between metal part, injection mortar and concrete.

The illustration and the description of the product are given in Annexes A.

### 2 Specification of the intended use

The performances given in Section 3 are only valid if the fastener is used in compliance with the specifications and conditions given in Annexes B.

The provisions made in this European technical assessment are based on an assumed working life of the fastener of 50 years. The indications given on the working life cannot be interpreted as a guarantee given by the producer, but are to be regarded only as a means for choosing the right products in relation to the expected economically reasonable working life of the works.

### 3 Performance of the product

#### 3.1 Mechanical resistance and stability (BWR 1)

Essential characteristic	Performance
Characteristic resistance for static and quasi static loads, Displacements	See Annex C1 to C21
Characteristic resistance for seismic performance category C1	See Annex C22 to C27
Characteristic resistance for seismic performance category C2, Displacements	See Annex C28 to C30

#### 3.2 Safety in case of fire (BWR 2)

Essential characteristic	Performance
Reaction to fire	Anchorage satisfy requirements for Class A1
Resistance to fire	No performance assessed

#### 3.3 Hygiene, health and the environment (BWR 3)

Regarding dangerous substances contained in this European technical approval, there may be requirements applicable to the products falling within its scope (e.g. transposed European legislation and national laws, regulations and administrative provisions). In order to meet the provisions of the Construction Products Directive, these requirements need also to be complied with, when and where they apply.

### 3.4 Safety in use (BWR 4)

For Basic requirement Safety in use the same criteria are valid as for Basic Requirement Mechanical resistance and stability.

### 3.5 Protection against noise (BWR 5)

Not relevant.

### 3.6 Energy economy and heat retention (BWR 6)

Not relevant.

### 3.7 Sustainable use of natural resources (BWR 7)

For the sustainable use of natural resources no performance was determined for this product.

### 3.8 General aspects relating to fitness for use

Durability and Serviceability are only ensured if the specifications of intended use according to Annex B1 are kept.

## 4 Assessment and verification of constancy of performance (AVCP)

According to the Decision 96/582/EC of the European Commission<sup>1</sup>, as amended, the system of assessment and verification of constancy of performance (see Annex V to Regulation (EU) No 305/2011) given in the following table apply.

Product	Intended use	Level or class	System
Metal fasteners for use in concrete	For fixing and/or supporting to concrete, structural elements (which contributes to the stability of the works) or heavy units	—	1

## 5 Technical details necessary for the implementation of the AVCP system

Technical details necessary for the implementation of the Assessment and verification of constancy of performance (AVCP) system are laid down in the control plan deposited at Centre Scientifique et Technique du Bâtiment.

The manufacturer shall, on the basis of a contract, involve a notified body approved in the field of fasteners for issuing the certificate of conformity CE based on the control plan.

### The original French version is signed by

Anca CRONOPOL  
La cheffe de division

---

<sup>1</sup> Official Journal of the European Communities L 254 of 08.10.1996

**Installed condition**

**Figure A1:** Threaded rod, HAS-U-..., HIT-V-..., AM...8.8

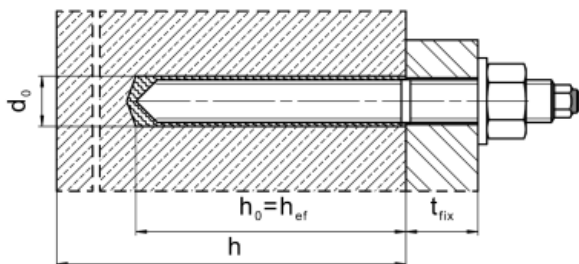

**Figure A2:** Threaded rod, HAS-U-..., HIT-V-..., AM...8.8, with Hilti Filling Set...

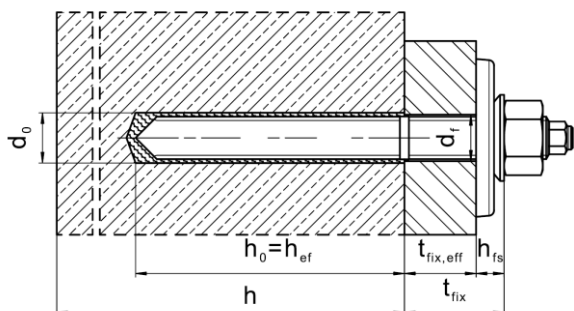

**Figure A3:** Internally threaded sleeve HIS-(R)N

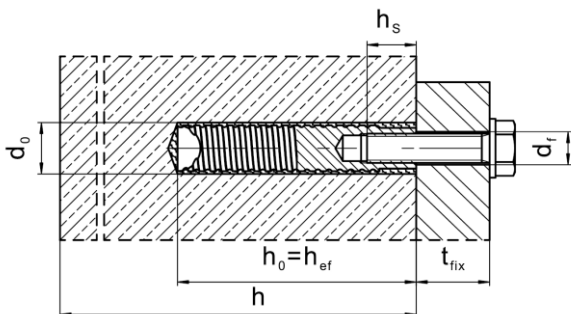

**Figure A4:** Reinforcing bar (rebar)

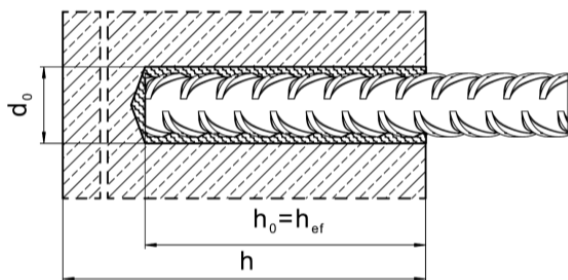

Injection system Hilti HIT-RE 500 V4

Product description  
 Installed condition

Annex A1

**Product description: Injection mortar and steel elements**

**Injection mortar Hilti HIT-RE 500 V4:** epoxy resin system with aggregate

330 ml, 500 ml and 1400 ml

Marking:  
 HILTI HIT  
 Product name  
 Production time and line  
 Expiry date mm/yyyy



Product name: "Hilti HIT-RE 500 V4"

**Static mixer Hilti HIT-RE-M**



**Steel elements**

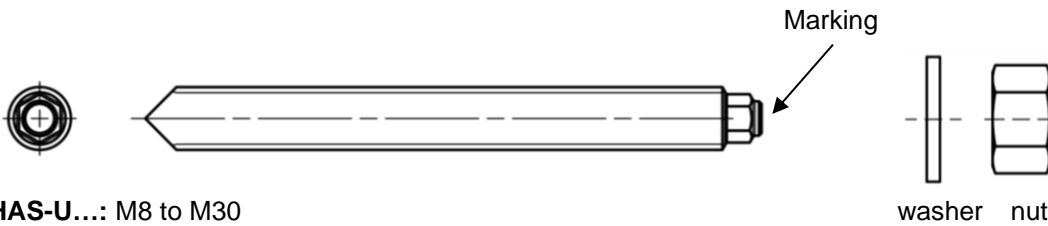

**HAS-U...:** M8 to M30

Marking: Steel grade number and length identification number

- 5 = HAS-U 5.8, 5.8 HDG
- 8 = HAS-U 8.8, 8.8. HDG
- 1 = HAS-U A4
- 2 = HAS-U HCR

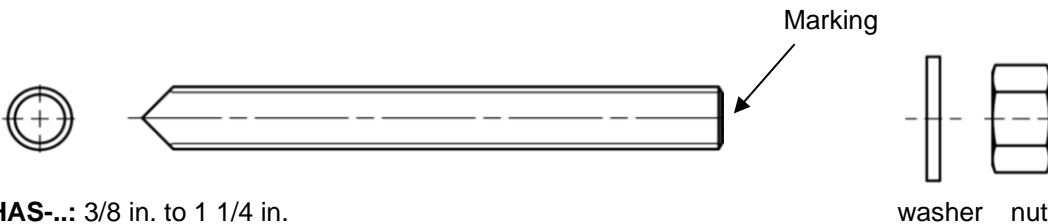

**HAS-...:** 3/8 in. to 1 1/4 in.

Marking: Steel grade and element length [in]

- V = HAS-V-36 (HDG)
- E = HAS-E-55
- B = HAS-B-105 (HDG)
- R1 = HAS-R 304
- R2 = HAS-R 316

**Injection system Hilti HIT-RE 500 V4**

**Product description**  
 Steel elements

**Annex A2**

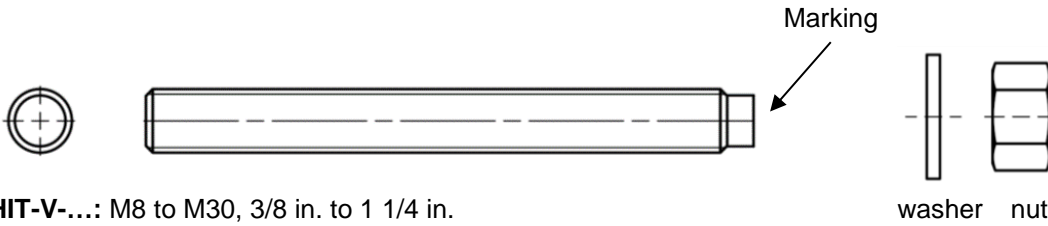

**HIT-V-...:** M8 to M30, 3/8 in. to 1 1/4 in.

Marking: e.g.

- 5.8 - l = HIT-V-5.8 M...x l
- 5.8F - l = HIT-V-5.8F M...x l
- 8.8 - l = HIT-V-8.8 M...x l
- 8.8F - l = HIT-V-8.8F M...x l
- R - l = HIT-V-R M ...x l
- HCR - l = HIT-V-HCR M ...x l

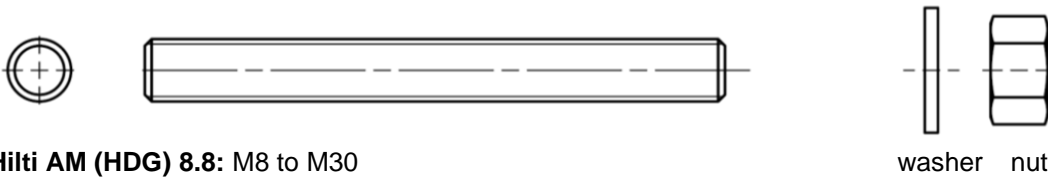

**Hilti AM (HDG) 8.8:** M8 to M30

**Commercial standard threaded rod:** M8 to M30, 3/8 in. to 1 1/4 in.

- Materials and mechanical properties according to Table A1.
- Inspection certificate 3.1 according to EN 10204:2004. The document shall be stored.
- Marking of embedment depth

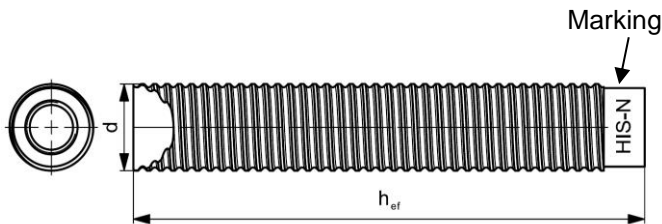

**Internally threaded sleeve HIS-(R)N:** M8 to M20, 3/8 in. to 3/4 in.

Marking:

Identifying mark - HILTI and embossing "HIS-N" (for zinc coated steel) or embossing "HIS-RN" (for stainless steel)

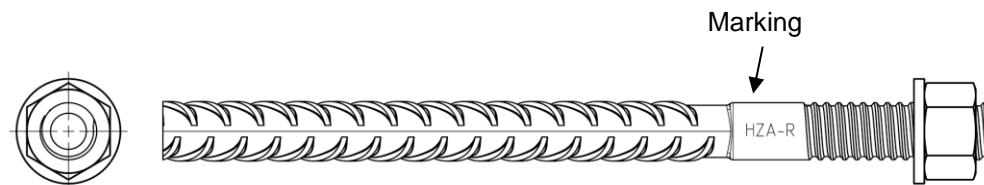

**Hilti Tension Anchor HZA:** M12 to M27

**Hilti Tension Anchor HZA-R:** M12 to M24

Marking:

embossing "HZA-R" M .. / tfix

**Injection system Hilti HIT-RE 500 V4**

**Product description**  
 Steel elements

**Annex A3**



**Reinforcing bar (rebar):**  $\phi$  8 to  $\phi$  32

- Materials and mechanical properties according to Table A2.
- Dimensions according to Annex B

**Hilti Filling Set to fill the annular gap between anchor and fixture**

Sealing washer

Spherical washer

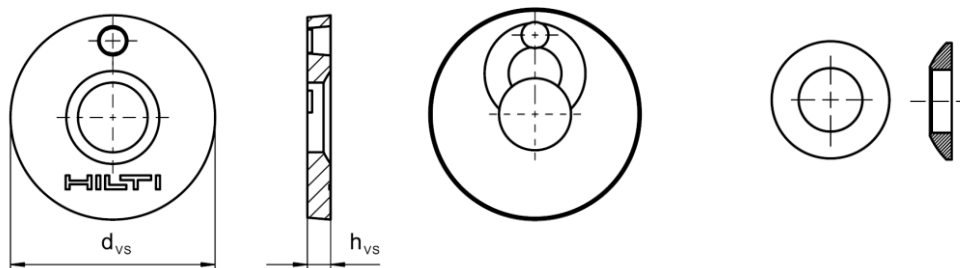

**Table A1: Geometry of Hilti Filling Set**

Hilti Filling Set		M16	M20	M24
Diameter of sealing washer	d <sub>vs</sub> [mm]	52	60	70
Thickness of sealing washer	h <sub>vs</sub> [mm]	6		
Thickness of Hilti Filling Set	h <sub>is</sub> [mm]	11	13	15

Injection system Hilti HIT-RE 500 V4

**Product description**  
 Steel elements

**Annex A4**

**Table A2: Materials**

Designation	Material
<b>Reinforcing bars (rebars)</b>	
Rebar EN 1992-1-1:2004 and AC:2010, Annex C	Bars and de-coiled rods class B or C with $f_{yk}$ and $k$ according to NDP or NCL of EN 1992-1-1/NA:2013 $f_{uk} = f_{tk} = k \cdot f_{yk}$
<b>Metal parts made of zinc coated steel</b>	
HAS-U-5.8 (HDG), HIT-V-5.8 (F), Threaded rod 5.8 (HDG)	Strength class 5.8, $f_{uk} = 500 \text{ N/mm}^2$ , $f_{yk} = 400 \text{ N/mm}^2$ Rupture elongation ( $l_0 = 5d$ ) > 8% ductile Electroplated zinc coated $\geq 5 \mu\text{m}$ , (F) or (HDG) hot dip galvanized $\geq 50 \mu\text{m}$
HAS-U-8.8 (HDG), HIT-V-8.8 (F), Threaded rod 8.8 (HDG)	Strength class 8.8, $f_{uk} = 800 \text{ N/mm}^2$ , $f_{yk} = 640 \text{ N/mm}^2$ Rupture elongation ( $l_0 = 5d$ ) > 12% ductile Electroplated zinc coated $\geq 5 \mu\text{m}$ , (F) or (HDG) hot dip galvanized $\geq 50 \mu\text{m}$
Hilti AM 8.8 (HDG)	Strength class 8.8, $f_{uk} = 800 \text{ N/mm}^2$ , $f_{yk} = 640 \text{ N/mm}^2$ Rupture elongation ( $l_0 = 5d$ ) > 12% ductile Electroplated zinc coated $\geq 5 \mu\text{m}$ , (HDG) hot dip galvanized $\geq 50 \mu\text{m}$
Hilti tension anchor HZA	Round steel with threaded part: electroplated zinc coated $\geq 5 \mu\text{m}$ Rebar: Bars class B according to NDP or NCL of EN 1992-1-1/NA
Internally threaded sleeve HIS-N	Electroplated zinc coated $\geq 5 \mu\text{m}$
HAS-V-36 (HDG)	ASTM F1554, Grade 36, $f_{uk} = 400 \text{ N/mm}^2$ , $f_{yk} = 248 \text{ N/mm}^2$ Rupture elongation ( $l_0 = 5d$ ) > 8% ductile Electroplated zinc coated $\geq 5 \mu\text{m}$ , (HDG) hot dip galvanized $\geq 53 \mu\text{m}$
HAS-E-55	ASTM F1554, Grade 55, $f_{uk} = 517 \text{ N/mm}^2$ , $f_{yk} = 379 \text{ N/mm}^2$ Rupture elongation ( $l_0 = 5d$ ) > 8% ductile Electroplated zinc coated $\geq 5 \mu\text{m}$
HAS-B-105 (HDG)	ASTM F1554, Grade 105, $f_{uk} = 862 \text{ N/mm}^2$ , $f_{yk} = 724 \text{ N/mm}^2$ Rupture elongation ( $l_0 = 5d$ ) > 8% ductile Electroplated zinc coated $\geq 5 \mu\text{m}$ , (HDG) hot dip galvanized $\geq 53 \mu\text{m}$
Washer	Electroplated zinc coated $\geq 5 \mu\text{m}$ , hot dip galvanized $\geq 50 \mu\text{m}$
Nut	Nominal strength class equal or higher to nominal strength class of rod. Electroplated zinc coated $\geq 5 \mu\text{m}$ , hot dip galvanized $\geq 50 \mu\text{m}$
Hilti Filling Set (F)	Filling washer: Electroplated zinc coated $\geq 5 \mu\text{m}$ , (F) hot dip galvanized $\geq 50 \mu\text{m}$ Spherical washer: Electroplated zinc coated $\geq 5 \mu\text{m}$ , (F) hot dip galvanized $\geq 50 \mu\text{m}$ Lock nut: Electroplated zinc coated $\geq 5 \mu\text{m}$ , (F) hot dip galvanized $\geq 6 \mu\text{m}$

**Injection system Hilti HIT-RE 500 V4**

**Product description**  
Materials

**Annex A5**

Table A2: continued

<b>Metal parts made of stainless steel</b>	
Corrosion class III acc. to EN 1993-1-4:2006+A1:2015	
HAS-U A4, HIT-V-R, Threaded rod A4	For $\leq$ M24: strength class 70, $f_{uk} = 700$ N/mm <sup>2</sup> , $f_{yk} = 450$ N/mm <sup>2</sup> For $>$ M24: strength class 50, $f_{uk} = 500$ N/mm <sup>2</sup> , $f_{yk} = 210$ N/mm <sup>2</sup> Rupture elongation ( $l_0 = 5d$ ) $>$ 8% ductile Stainless steel according to EN 10088-1: 2014
Hilti tension anchor HZA-R	Round steel with threaded part: Stainless steel according to EN 10088-1:2014 Rebar: Bars class B according to NDP or NCL of EN 1992-1-1/NA:2013
Internally threaded sleeve HIS-RN	Stainless steel according to EN 10088-1:2014
HAS-R 304	Size 3/8 in. to 5/8 in.: ASTM F593 CW1, $f_{uk} = 689$ N/mm <sup>2</sup> , $f_{yk} = 448$ N/mm <sup>2</sup> Rupture elongation ( $l_0 = 5d$ ) $>$ 8% ductile Size 3/4 in. to 1 in.: ASTM F593 CW2, $f_{uk} = 586$ N/mm <sup>2</sup> , $f_{yk} = 310$ N/mm <sup>2</sup> Rupture elongation ( $l_0 = 5d$ ) $>$ 8% ductile Size $>$ 1 in.: ASTM A193 Grade 8 M, class 1, $f_{uk} = 515$ N/mm <sup>2</sup> , $f_{yk} = 205$ N/mm <sup>2</sup> Rupture elongation ( $l_0 = 5d$ ) $>$ 8% ductile
HAS-R 316	Size 3/8 in. to 5/8 in.: ASTM F593 CW1, $f_{uk} = 689$ N/mm <sup>2</sup> , $f_{yk} = 448$ N/mm <sup>2</sup> Rupture elongation ( $l_0 = 5d$ ) $>$ 8% ductile Size 3/4 in. to 1 1/4 in.: ASTM F 593 CW2, $f_{uk} = 586$ N/mm <sup>2</sup> , $f_{yk} = 310$ N/mm <sup>2</sup> Rupture elongation ( $l_0 = 5d$ ) $>$ 8% ductile
Washer	Stainless steel according to EN 10088-1: 2014 ASTM A240 (type 304) and ASTM A480 (type 316)
Nut	Nominal strength class equal or higher to nominal strength class of rod. Stainless steel according to EN 10088-1: 2014 ASTM F594, type 304 CW and type 316 CW
<b>Metal parts made of high corrosion resistant steel</b>	
Corrosion class V acc. to EN 1993-1-4:2006+A1:2015	
HAS-U HCR, HIT-V-HCR, Threaded rod HCR	For $\leq$ M20: $f_{uk} = 800$ N/mm <sup>2</sup> , $f_{yk} = 640$ N/mm <sup>2</sup> For $>$ M20: $f_{uk} = 700$ N/mm <sup>2</sup> , $f_{yk} = 400$ N/mm <sup>2</sup> Rupture elongation ( $l_0 = 5d$ ) $>$ 8% ductile High corrosion resistant steel according to EN 10088-1:2014
Washer	High corrosion resistant steel according to EN 10088-1:2014
Nut	Nominal strength class equal or higher to nominal strength class of rod. High corrosion resistant steel according to EN 10088-1:2014

Injection system Hilti HIT-RE 500 V4

Product description  
Materials

Annex A6

## Specifications of intended use

### Anchorage subject to:

- Static and quasi static loading.
- Seismic performance category C1.
- Seismic performance category C2 (HAS-U (8.8, 8.8 HDG, HCR), HIT-V (-8.8, 8.8F, -HCR), AM (8.8, 8.8 HDG) and standard threaded rod (grade 8.8, HCR)), with hammer drilling and hammer drilling with Hilti hollow drill bit TE-CD, TE-YD.

### Base material:

- Compacted reinforced or unreinforced normal weight concrete without fibres according to EN 206:2013+A1:2016.
- Strength classes C20/25 to C50/60 according to EN 206:2013+A1:2016.
- Cracked and uncracked concrete.

### Temperature in the base material:

- **at installation**  
-5 °C to +40 °C for the standard variation of temperature after installation
- **in-service**  
Temperature range I: -40 °C to +40 °C  
(max. long term temperature +24 °C and max. short term temperature +40 °C)  
Temperature range II: -40 °C to +55 °C  
(max. long term temperature +43 °C and max. short term temperature +55 °C)  
Temperature range III: -40 °C to +75 °C  
(max. long term temperature +55 °C and max. short term temperature +75 °C)

### Use conditions (Environmental conditions):

- Structures subject to dry internal conditions (all materials)  
(zinc coated steel, stainless steel or high corrosion resistant steel).
- For all other conditions according EN 1993-1-4:2006+A1:2015-06 corresponding to corrosion resistance classes Annex A (stainless steel and high corrosion resistant steel).

### Design:

- Anchorages are designed under the responsibility of an engineer experienced in anchorages and concrete work.
- Verifiable calculation notes and drawings are prepared taking account of the loads to be anchored. The position of the anchor is indicated on the design drawings (e. g. position of the anchor relative to reinforcement or to supports, etc.).
- The anchorages are designed in accordance with EN 1992-4:2018 and EOTA Technical Report TR 055. Anchorages under seismic actions shall be positioned outside of critical regions (e.g. plastic hinges) of the concrete structure. Fastening in stand-off installation or with a grout layer under seismic action are not covered in this European technical assessment (ETA).

### Installation:

- Use category:
  - dry or wet concrete (not in water-filled drill holes): for all drilling techniques.
  - water-filled drill holes: for hammer drilling only, for uncracked concrete only
- Drilling technique:
  - hammer drilling,
  - hammer drilling with Hilti hollow drill bit TE-CD, TE-YD,
  - diamond coring, for uncracked concrete only,
  - diamond coring with roughening with Hilti Roughening tool TE-YRT.
- Installation direction D3: downward, horizontal and upward (e.g. overhead) installation admissible for all elements.
- Anchor

Injection system Hilti HIT-RE 500 V4

Intended use  
Specifications

Annex B1

**Table B1: Installation parameters of threaded rod, HAS-U-..., HIT-V-... and AM...8.8**

Threaded rod, HAS-U-..., HIT-V-..., AM...8.8			M8	M10	M12	M16	M20	M24	M27	M30
Diameter of element	d	[mm]	8	10	12	16	20	24	27	30
Nominal diameter of drill bit	d <sub>0</sub>	[mm]	10	12	14	18	22	28	30	35
Effective embedment depth and drill hole depth	h <sub>ef</sub>	[mm]	60 to 160	60 to 200	70 to 240	80 to 320	90 to 400	96 to 480	108 to 540	120 to 600
Maximum diameter of clearance hole in the fixture	d <sub>f</sub>	[mm]	9	12	14	18	22	26	30	33
Thickness of Hilti filling set	h <sub>fs</sub>	[mm]	-	-	-	11	13	15	-	-
Effective fixture thickness with Hilti filling set	t <sub>fix,eff</sub>	[mm]	$t_{fix,eff} = t_{fix} - h_{fs}$							
Minimum thickness of concrete member	h <sub>min</sub>	[mm]	$h_{ef} + 30 \geq 100 \text{ mm}$			$h_{ef} + 2 \cdot d_0$				
Maximum installation torque	max. T <sub>inst</sub>	[Nm]	10	20	40	80	150	200	270	300
Minimum spacing	s <sub>min</sub>	[mm]	40	50	60	75	90	115	120	140
Minimum edge distance	c <sub>min</sub>	[mm]	40	45	45	50	55	60	75	80

**Table B2: Installation parameters of threaded rod, HAS-... and HIT-V-...**

Threaded rod, HAS-..., HIT-V-..., size			3/8	1/2	5/8	3/4	7/8	1	1 1/4
Diameter of element	d	[mm]	9,5	12,7	15,9	19,1	22,2	25,4	31,8
Nominal diameter of drill bit	d <sub>0</sub>	[in.]	7/16	9/16	3/4	7/8	1	1 1/8	1 3/8
Effective cross sectional area	A <sub>s</sub> <sup>1)</sup>	[mm <sup>2</sup> ]	50	92	146	216	298	391	625
Effective embedment depth and drill hole depth	h <sub>ef</sub>	[mm]	60 to 191	70 to 254	79 to 318	89 to 381	89 to 445	102 to 508	127 to 635
Maximum diameter of clearance hole in the fixture	d <sub>f</sub>	[mm]	11,1	14,3	17,5	20,6	23,8	28,6	34,9
Minimum thickness of concrete member	h <sub>min</sub>	[mm]	$h_{ef} + 30 \geq 100 \text{ mm}$			$h_{ef} + 2 \cdot d_0$			
Maximum installation torque	max. T <sub>inst</sub>	[Nm]	20	41	81	136	169	203	271
Minimum spacing	s <sub>min</sub>	[mm]	45	60	80	90	105	115	140
Minimum edge distance	c <sub>min</sub>	[mm]	45	45	50	55	60	70	80

1) Effectice cross sectional area for calculation of characteristic steel resistance.

**Injection system Hilti HIT-RE 500 V4**

**Intended use**  
Installation parameters

**Annex B2**

**Table B3: Installation parameters of internally threaded sleeve HIS-(R)N**

Internally threaded sleeve HIS-(R)N			M8	M10	M12	M16	M20
Outer diameter of sleeve	d	[mm]	12,5	16,5	20,5	25,4	27,6
Nominal diameter of drill bit	d <sub>0</sub>	[mm]	14	18	22	28	32
Effective embedment depth and drill hole depth	h <sub>ef</sub>	[mm]	90	110	125	170	205
Maximum diameter of clearance hole in the fixture <sup>3)</sup>	d <sub>f</sub>	[mm]	9	12	14	18	22
Minimum thickness of concrete member	h <sub>min</sub>	[mm]	120	150	170	230	270
Maximum installation torque	max. T <sub>inst</sub>	[Nm]	10	20	40	80	150
Thread engagement length min-max	h <sub>s</sub>	[mm]	8 to 20	10 to 25	12 to 30	16 to 40	20 to 50
Minimum spacing	s <sub>min</sub>	[mm]	60	75	90	115	130
Minimum edge distance	c <sub>min</sub>	[mm]	40	45	55	65	90

**Table B4: Installation parameters of internally threaded sleeve HIS-(R)N**

Internally threaded sleeve HIS-(R)N, size		[in.]	3/8	1/2	5/8	3/4
Outer diameter of sleeve	d	[mm]	16,5	20,5	25,4	27,6
Nominal diameter of drill bit	d <sub>0</sub>	[in.]	11/16	7/8	1 1/8	1
Effective embedment depth and drill hole depth	h <sub>ef</sub>	[mm]	110	125	170	205
Maximum diameter of clearance hole in the fixture	d <sub>f</sub>	[mm]	11,1	14,3	17,5	20,6
Minimum thickness of concrete member	h <sub>min</sub>	[mm]	150	170	230	270
Maximum installation torque	max. T <sub>inst</sub>	[Nm]	20	41	81	136
Thread engagement length min to max	h <sub>s</sub>	[mm]	10 to 25	12 to 30	16 to 40	20 to 50
Minimum spacing	s <sub>min</sub>	[mm]	70	90	115	130
Minimum edge distance	c <sub>min</sub>	[mm]	45	55	65	90

**Injection system Hilti HIT-RE 500 V4**

**Intended use**  
 Installation parameters

**Annex B3**

**Table B5: Installation parameters of Hilti tension anchor HZA / HZA-R**

Hilti tension anchor HZA		M12	M16	M20	M24	M27
Hilti tension anchor HZA-R		M12	M16	M20	M24	-
Rebar diameter	$\phi$ [mm]	12	16	20	25	28
Nominal embedment depth and drill hole depth HZA	$h_0$ [mm]	90 to 240	100 to 320	110 to 400	120 to 500	140 to 560
Nominal embedment depth and drill hole depth HZA-R	$h_0$ [mm]	170 to 240	180 to 320	190 to 400	200 to 500	-
Effective embedment depth HZA ( $h_{ef} = h_{nom} - l_e$ )	$h_{ef}$ [mm]	$h_{nom} - 20$				
Effective embedment depth HZA-R ( $h_{ef} = h_{nom} - l_e$ )	$h_{ef}$ [mm]	$h_{nom} - 100$				
Length of smooth shaft HZA	$l_e$ [mm]	20				
Length of smooth shaft HZA-R		100				
Nominal diameter of drill bit	$d_0$ [mm]	16	20	25	32	35
Maximum diameter of clearance hole in the fixture	$d_f$ [mm]	14	18	22	26	30
Maximum installation torque	max. $T_{inst}$ [Nm]	40	80	150	200	270
Minimum thickness of concrete member	$h_{min}$ [mm]	$h_{nom} + 2 \cdot d_0$				
Minimum spacing	$s_{min}$ [mm]	65	80	100	130	140
Minimum edge distance	$c_{min}$ [mm]	45	50	55	60	75

**Table B6: Installation parameters of reinforcing bar (rebar)**

Reinforcing bar (rebar)		$\phi 8$	$\phi 10$	$\phi 12$	$\phi 14$	$\phi 16$	$\phi 20$	$\phi 25$	$\phi 28$	$\phi 30$	$\phi 32$
Diameter	$\phi$ [mm]	8	10	12	14	16	20	25	28	30	32
Effective embedment depth and drill hole depth	$h_{ef}$ [mm]	60 to 160	60 to 200	70 to 240	75 to 280	80 to 320	90 to 400	100 to 500	112 to 560	120 to 600	128 to 640
Nominal diameter of drill bit	$d_0$ [mm]	10 <sup>1)</sup> 12 <sup>1)</sup>	12 <sup>1)</sup> 14 <sup>1)</sup>	14 <sup>1)</sup> 16 <sup>1)</sup>	18	20	25	30 <sup>1)</sup> 32 <sup>1)</sup>	35	37	40
Minimum thickness of concrete member	$h_{min}$ [mm]	$h_{ef} + 30$ $\geq 100$ mm			$h_{ef} + 2 \cdot d_0$						
Minimum spacing	$s_{min}$ [mm]	40	50	60	70	80	100	125	140	150	160
Minimum edge distance	$c_{min}$ [mm]	40	45	45	50	50	65	70	75	80	80

1) Each of the two given values can be used.

Injection system Hilti HIT-RE 500 V4

Intended use  
Installation parameters

Annex B4

**Table B7: Working and curing time<sup>1) 2)</sup>**

Temperature in the base material T	Maximum working time t <sub>work</sub>	Minimum curing time t <sub>cure</sub> <sup>1)</sup>
-5 °C to -1 °C	2 hours	168 hours
0 °C to 4 °C	2 hours	48 hours
5 °C to 9 °C	2 hours	24 hours
10 °C to 14 °C	1,5 hours	16 hours
15 °C to 19 °C	1 hour	12 hours
20 °C to 24 °C	30 min	7 hours
25 °C to 29 °C	20 min	6 hours
30 °C to 34 °C	15 min	5 hours
35 °C to 39 °C	12 min	4,5 hours
40 °C	10 min	4 hours











- 1) The curing time data are valid for dry base material only. In wet base material the curing times must be doubled.  
 2) The minimum temperature of the foil pack is +5° C.

**Injection system Hilti HIT-RE 500 V4**

**Intended use**  
 Working and curing time







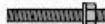

**Annex B5**

**Table B8: Parameters of cleaning and setting tools**

Elements				Drill and clean				Installation	
Threaded rod, HAS-U-... HIT-V-... AM...8.8	HIS-(R)N	Rebar	HZA(-R)	Hammer drilling		Diamond coring		Brush	Piston plug
				Hollow drill bit TE-CD, TE-YD		Roughening tool TE-YRT			
									
Size	Size	Size	Size	d <sub>0</sub> [mm]	d <sub>0</sub> [mm]	d <sub>0</sub> [mm]	d <sub>0</sub> [mm]	HIT-RB	HIT-SZ
M8	-	φ 8	-	10	-	10	-	10	-
M10	-	φ 8, φ 10	-	12	-	12	-	12	12
M12	M8	φ 10, φ 12	-	14	14 <sup>1)</sup>	14	-	14	14
-	-	φ 12	M12	16	16	16	-	16	16
M16	M10	φ 14	-	18	18	18	18	18	18
-	-	φ 16	M16	20	20	20	20	20	20
M20	M12	-	-	22	22	22	22	22	22
-	-	φ 20	M20	25	25	25	25	25	25
M24	M16	-	-	28	28	28	28	28	28
M27	-	φ 25	-	30	-	30	30	30	30
-	M20	φ 25	M24	32	32	32	32	32	32
M30	-	φ 28	M27	35	35	35	35	35	35
-	-	φ 30	-	37	-	37	-	37	37
-	-	φ 32	-	40	-	-	-	40	40
-	-	φ 32	-	-	-	42	-	42	42

<sup>1)</sup> To be used in combination with Hilti vacuum cleaner with suction volume ≥ 61 l/s (VC 20/40 –Y in corded mode only).

**Table B9: Parameters of cleaning and setting tools**

Elements		Drill and clean				Installation	
Threaded rod, HAS-... HIT-V-...	HIS-(R)N	Hammer drilling		Diamond coring		Brush	Piston plug
		Hollow drill bit TE-CD, TE-YD		Roughening tool TE-YRT			
							
Size [in]	Size [in]	d <sub>0</sub> [in.]	d <sub>0</sub> [in.]	d <sub>0</sub> [in.]	d <sub>0</sub> [in.]	HIT-RB	HIT-SZ
3/8	-	7/16	-	7/16	-	7/16	7/16
1/2	-	9/16	9/16	9/16	-	9/16	9/16
-	3/8	11/16	-	11/16	-	11/16	11/16
5/8	-	3/4	3/4	3/4	3/4	3/4	3/4
3/4	1/2	7/8	7/8	7/8	7/8	7/8	7/8
7/8	-	1	1	1	1	1	1
1	5/8	1 1/8	1 1/8	1 1/8	1 1/8	1 1/8	1 1/8
-	3/4	1 1/4	-	1 1/4	-	1 1/4	1 1/4
1 1/4	-	1 3/8	-	1 3/8	1 3/8	1 3/8	1 3/8



Injection system Hilti HIT-RE 500 V4

**Intended use**



Overview of installation options / Parameters of cleaning and setting tools

**Annex B6**

**Table B10: Cleaning alternatives**

<p><b>Compressed Air Cleaning (CAC):</b> air nozzle with an orifice opening of minimum 3,5 mm (1/7 in.) in diameter.</p>	
<p><b>Automatic Cleaning (AC):</b> Cleaning is performed during drilling with Hilti TE-CD and TE-YD drilling system including vacuum cleaner.</p>	

**Table B11: Parameters for use of the Hilti Raoughening tool TE-YRT**

Diamond coring			Roughening tool TE-YRT		Wear gauge RTG...	
						
$d_0$					size	
nominal [mm]	nominal [in.]	measured [mm]	$d_0$ [mm]	$d_0$ [in.]		
18	3/4	17,9 to 18,2	18	3/4	18	3/4
20	7/8	19,9 to 20,2	20	7/8	20	7/8
22	1	21,9 to 22,2	22	1	22	1
25	1 1/8	24,9 to 25,2	25	1 1/8	25	1 1/8
28	1 3/8	27,9 to 28,2	28	1 3/8	28	1 3/8
30	-	29,9 to 30,2	30	-	30	-
32	-	31,9 to 32,2	32	-	32	-
35	-	34,9 to 35,2	35	-	35	-

**Table B12: Installation parameters for use of the Hilti Roughening tool TE-YRT**

$h_{ef}$ [mm]	Roughening time $t_{roughen}$ ( $t_{roughen}$ [sec] = $h_{ef}$ [mm] / 10)
0 to 100	10
101 to 200	20
201 to 300	30
301 to 400	40
401 to 500	50
501 to 600	60

**Table B13: Hilti Roughening tool TE-YRT and wear gauge RTG**

TE-YRT	
RTG	

<b>Injection system Hilti HIT-RE 500 V4</b>	<b>Annex B7</b>
<b>Intended use</b> Cleaning alternatives / Parameters for use of roughening tool	

## Installation instruction

### Hole drilling

**a) Hammer drilling:** For dry or wet concrete and installation in water-filled drill holes (no sea water).

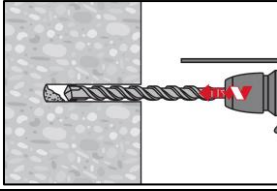

Drill hole to the required embedment depth with a hammer drill set in rotation-hammer mode using an appropriately sized carbide drill bit.

**b) Hammer drilling with Hilti hollow drill bit TE-CD, TE-YD:** For dry and wet concrete only.

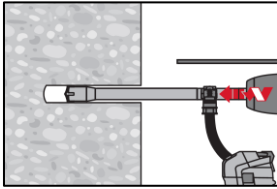

Drill hole to the required embedment depth with an appropriately sized Hilti TE-CD or TE-YD hollow drill bit attached to Hilti vacuum cleaner VC 20/40 (-Y) (suction volume  $\geq 57$  l/s) with automatic cleaning of the filter activated. This drilling system removes the dust and cleans the bore hole during drilling when used in accordance with the user's manual. When using TE-CD 14 refer to Table B8 and Table B9. After drilling is completed, proceed to the "injection preparation" step in the installation instruction.

**c) Diamond coring:** For dry and wet concrete only.

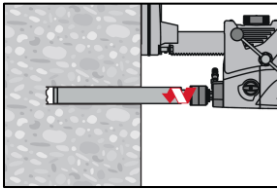

Diamond coring is permissible when suitable diamond core drilling machines and the corresponding core bits are used.

**d) Diamond coring with roughening with Hilti Roughening tool TE-YRT:** For dry and wet concrete only.

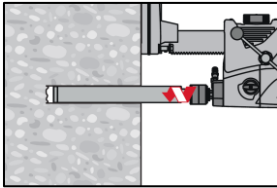

Diamond coring is permissible when suitable diamond core drilling machines and the corresponding core bits are used.

For the use in combination with Hilti Roughening tool TE-YRT see parameters in Table B8 and Table B9.

Before roughening free water needs to be removed from the borehole. Check usability of the roughening tool with the wear gauge RTG.

Roughen the borehole over the whole length to the required  $h_{ef}$ .

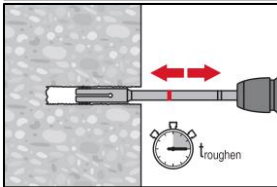

Injection system Hilti HIT-RE 500 V4

Intended use  
Installation instructions

Annex B8

**Drill hole cleaning:** Just before setting an anchor, the drill hole must be free of dust and debris.  
Inadequate hole cleaning = poor load values.

**Compressed Air Cleaning (CAC):** For all drill hole diameters  $d_0$  and all drill hole depths  $h_0$ .

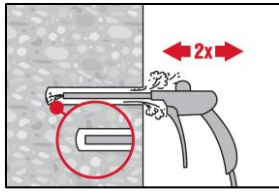

Blow 2 times from the back of the hole (if needed with nozzle extension) over the whole length with oil-free compressed air (min. 6 bar at 6 m<sup>3</sup>/h) until return air stream is free of noticeable dust.

For drill hole diameters  $\geq 32$  mm the compressor has to supply a minimum air flow of 140 m<sup>3</sup>/h.

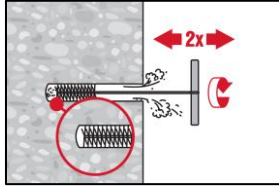

Brush 2 times with the specified brush (see Table B8 and Table B9) by inserting the steel brush Hilti HIT-RB to the back of the hole (if needed with extension) in a twisting motion and removing it.

The brush must produce natural resistance as it enters the drill hole (brush  $\varnothing \geq$  drill hole  $\varnothing$ ) - if not the brush is too small and must be replaced with the proper brush diameter.

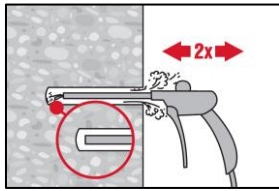

Blow again with compressed air 2 times until return air stream is free of noticeable dust.

Injection system Hilti HIT-RE 500 V4

Intended use  
Installation instructions

Annex B9

### Cleaning of hammer drilled water-filled drill holes and diamond cored holes:

For all drill hole diameters  $d_0$  and all drill hole depths  $h_0$ .

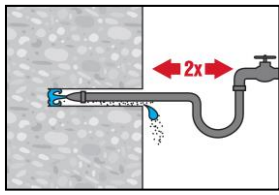

Flush 2 times by inserting a water hose (water-line pressure) to the back of the hole until water runs clear.

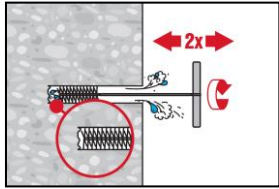

Brush 2 times with the specified brush (see Table B8 and Table B9) by inserting the steel brush Hilti HIT-RB to the back of the hole (if needed with extension) in a twisting motion and removing it.  
The brush must produce natural resistance as it enters the drill hole (brush  $\varnothing \geq$  drill hole  $\varnothing$ ) - if not the brush is too small and must be replaced with the proper brush diameter.

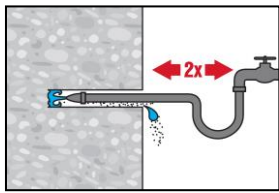

Flush 2 times by inserting a water hose (water-line pressure) to the back of the hole until water runs clear.

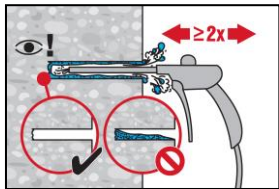

Blow 2 times from the back of the hole (if needed with nozzle extension) over the whole length with oil-free compressed air (min. 6 bar at 6 m<sup>3</sup>/h) until return air stream is free of noticeable dust and water.  
For drill hole diameters  $\geq 32$  mm the compressor has to supply a minimum air flow of 140 m<sup>3</sup>/h.

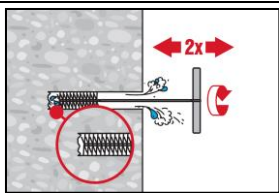

Brush 2 times with the specified brush size (see Table B8 and Table B9) by inserting the steel brush Hilti HIT-RB to the back of the hole (if needed with extension) in a twisting motion and removing it.  
The brush must produce natural resistance as it enters the drill hole – if not the brush is too small and must be replaced with the proper brush diameter.

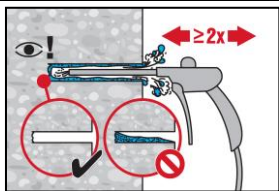

Blow again with compressed air 2 times until return air stream is free of noticeable dust and water.

Injection system Hilti HIT-RE 500 V4

Intended use  
Installation instructions

Annex B10

**Cleaning of diamond cored holes with roughening with Hilti Roughening tool TE-YRT:**

For all drill hole diameters  $d_0$  and all drill hole depths  $h_0$ .

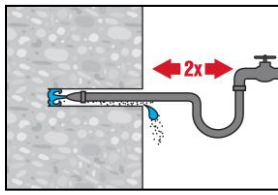

Flush 2 times by inserting a water hose (water-line pressure) to the back of the hole until water runs clear.

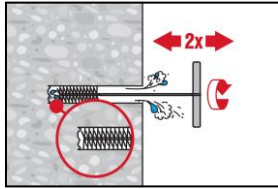

Brush 2 times with the specified brush (see Table B8 and Table B9) by inserting the steel brush Hilti HIT-RB to the back of the hole (if needed with extension) in a twisting motion and removing it. The brush must produce natural resistance as it enters the drill hole (brush  $\varnothing \geq$  drill hole  $\varnothing$ ) - if not the brush is too small and must be replaced with the proper brush diameter.

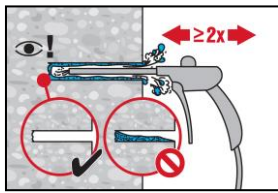

Blow 2 times from the back of the hole (if needed with nozzle extension) over the whole length with oil-free compressed air (min. 6 bar at 6 m<sup>3</sup>/h) until return air stream is free of noticeable dust and water. For drill hole diameters  $\geq 32$  mm the compressor has to supply a minimum air flow of 140 m<sup>3</sup>/h.

**Injection preparation**

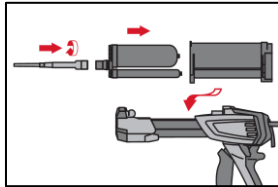

Tightly attach Hilti mixing nozzle HIT-RE-M to foil pack manifold. Do not modify the mixing nozzle. Observe the instruction for use of the dispenser. Check foil pack holder for proper function. Insert foil pack into foil pack holder and put holder into dispenser.

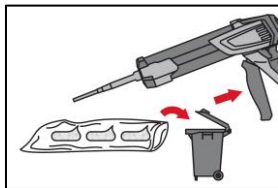

The foil pack opens automatically as dispensing is initiated. Depending on the size of the foil pack an initial amount of adhesive has to be discarded. Discarded quantities are:

3 strokes	for 330 ml foil pack,
4 strokes	for 500 ml foil pack,
65 ml	for 1400 ml foil pack.

**Injection system Hilti HIT-RE 500 V4**

**Intended use**  
 Installation instructions

**Annex B11**

### Inject adhesive from the back of the drill hole without forming air voids.

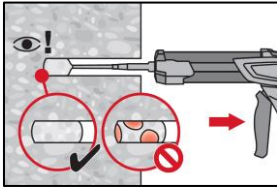

Inject the adhesive starting at the back of the hole, slowly withdrawing the mixer with each trigger pull.  
Fill approximately 2/3 of the drill hole to ensure that the annular gap between the anchor and the concrete is completely filled with adhesive along the embedment length.

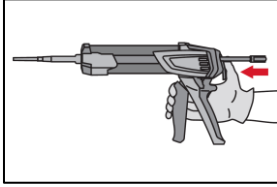

After injection is completed, depressurize the dispenser by pressing the release trigger. This will prevent further adhesive discharge from the mixer.

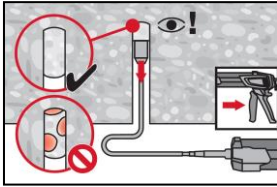

Overhead installation and/or installation with embedment depth  $h_{ef} > 250$  mm.  
For overhead installation the injection is only possible with the aid of extensions and piston plugs. Assemble HIT-RE-M mixer, extension(s) and appropriately sized piston plug (see Table B8 and Table B9). Insert piston plug to back of the hole and inject adhesive. During injection the piston plug will be naturally extruded out of the drill hole by the adhesive pressure.

### Setting the element

Just before setting an anchor, the drill hole must be free of dust and debris.

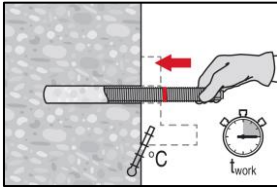

Before use, verify that the element is dry and free of oil and other contaminants.  
Mark and set element to the required embedment depth before working time  $t_{work}$  has elapsed. The working time  $t_{work}$  is given in Table B6.

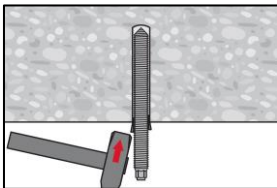

For overhead installation use piston plugs and fix embedded parts with e.g. wedges.

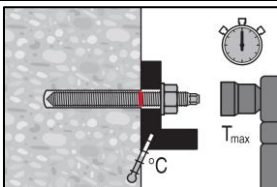

Loading the anchor: After required curing time  $t_{cure}$  (see Table B7) the anchor can be loaded.  
The applied installation torque shall not exceed the values  $max. T_{inst}$  given in Table B1 to Table B5.

Injection system Hilti HIT-RE 500 V4

Intended use  
Installation instructions

Annex B12

### Installation of Filling Set

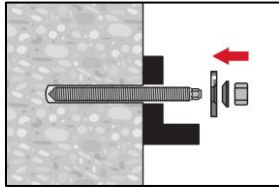

Use Hilti filling set with standard nut. Observe the correct orientation of filling washer and spherical washer.

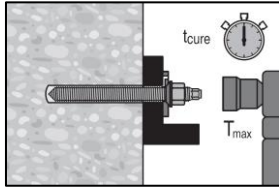

The applied installation torque shall not exceed the values max.  $T_{inst}$  given in in Table B1 to Table B5.

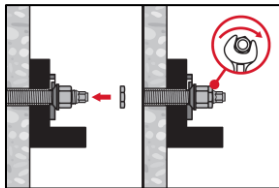

Optional:  
Installation of lock nut. Tighten with a  $\frac{1}{4}$  to  $\frac{1}{2}$  turn. (Not for size M24.)

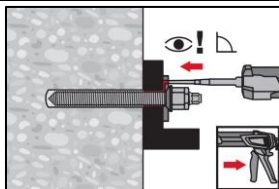

Fill the annular gap between the anchor rod and fixture with 1-3 strokes of a Hilti injection mortar HIT-HY ... or HIT-RE ... .  
Follow the installation instructions supplied with the Hilti injection mortar.  
After required curing time  $t_{cure}$  (see Table B7) the anchor can be loaded.

Injection system Hilti HIT-RE 500 V4

Intended use  
Installation instructions

Annex B13

**Table C1: Essential characteristics for threaded rods under tension load in concrete**

Threaded rod, HAS-U-..., HIT-V-..., AM...8.8			M8	M10	M12	M16	M20	M24	M27	M30	
<b>Steel failure</b>											
Characteristic resistance	$N_{Rk,s}$	[kN]	$A_s \cdot f_{uk}$								
Partial factor grade 5.8, 8.8	$\gamma_{Ms,N}^{1)}$	[-]	1,5								
Partial factor HAS-U A4, HIT-V-R	$\gamma_{Ms,N}^{1)}$	[-]	1,87						2,86		
Partial factor HAS-U HCR, HIT-V-HCR	$\gamma_{Ms,N}^{1)}$	[-]	1,5						2,1		
<b>Installation factor</b>											
Hammer drilling	$\gamma_{inst}$	[-]	1,0								
Hammer drilling with Hilti hollow drill bit TE-CD or TE-YD	$\gamma_{inst}$	[-]	2)		1,0						
Diamond coring	$\gamma_{inst}$	[-]	1,2			1,4					
Diamond coring with roughening with Hilti Roughening tool TE-YRT	$\gamma_{inst}$	[-]	2)		1,0						
Hammer drilling in water-filled drill holes	$\gamma_{inst}$	[-]	1,4								
<b>Concrete cone failure</b>											
Factor for cracked concrete	$k_{Cr,N}$	[-]	7,7								
Factor for uncracked concrete	$k_{ucr,N}$	[-]	11,0								
Edge distance	$c_{Cr,N}$	[mm]	$1,5 \cdot h_{ef}$								
Spacing	$s_{Cr,N}$	[mm]	$3,0 \cdot h_{ef}$								
<b>Splitting failure</b>											
Edge distance $c_{Cr,sp}$ [mm] for	$h / h_{ef} \geq 2,0$		$1,0 \cdot h_{ef}$								
	$2,0 > h / h_{ef} > 1,3$		$4,6 \cdot h_{ef} - 1,8 \cdot h$								
	$h / h_{ef} \leq 1,3$		$2,26 \cdot h_{ef}$								
Spacing	$s_{Cr,sp}$	[mm]	$2 \cdot c_{Cr,sp}$								
<b>Combined pullout and concrete cone failure</b>											
Characteristic resistance in uncracked concrete C20/25 in hammer drilled holes and hammer drilled holes with Hilti hollow drill bit TE-CD or TE-YD and diamond cored holes with roughening with Hilti Roughening tool TE-YRT											
Temperature range I:	40°C / 24°C	$\tau_{Rk,ucr}$	[N/mm <sup>2</sup> ]	19	18	18	17	16	15	15	14
Temperature range II:	55°C / 43°C	$\tau_{Rk,ucr}$	[N/mm <sup>2</sup> ]	16	15	15	14	13	13	12	12
Temperature range III:	75°C / 55°C	$\tau_{Rk,ucr}$	[N/mm <sup>2</sup> ]	6,0	6,0	6,0	5,5	5,0	5,0	4,5	4,5

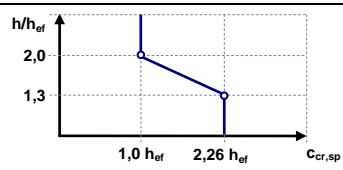

<b>Injection system Hilti HIT-RE 500 V4</b>	<b>Annex C1</b>
<b>Performances</b> Essential characteristics under tension load in concrete	

**Table C1: continued**

Threaded rod, HAS-U-..., HIT-V-..., AM...8.8				M8	M10	M12	M16	M20	M24	M27	M30	
Characteristic resistance in uncracked concrete C20/25 in <b>diamond cored holes</b>												
Temperature range I:	40°C / 24°C	$\tau_{Rk,ucr}$	[N/mm <sup>2</sup> ]	13	13	13	13	12	12	12	12	
Temperature range II:	55°C / 43°C	$\tau_{Rk,ucr}$	[N/mm <sup>2</sup> ]	12	12	11	11	11	11	11	10	
Temperature range III:	75°C / 55°C	$\tau_{Rk,ucr}$	[N/mm <sup>2</sup> ]	6,0	5,5	5,5	5,5	5,5	5,5	5,5	5,0	
Characteristic resistance in uncracked concrete C20/25 in <b>hammer drilled holes and installation in water-filled drill holes</b>												
Temperature range I:	40°C / 24°C	$\tau_{Rk,ucr}$	[N/mm <sup>2</sup> ]	16	16	15	15	14	13	12	12	
Temperature range II:	55°C / 43°C	$\tau_{Rk,ucr}$	[N/mm <sup>2</sup> ]	13	13	13	12	11	11	10	10	
Temperature range III:	75°C / 55°C	$\tau_{Rk,ucr}$	[N/mm <sup>2</sup> ]	5,0	5,0	5,0	4,5	4,5	4,0	4,0	4,0	
Characteristic resistance in cracked concrete C20/25 in <b>hammer drilled holes and hammer drilled holes with Hilti hollow drill bit TE-CD or TE-YD and diamond cored holes with roughening with Hilti Roughening tool TE-YRT</b>												
Temperature range I:	40°C / 24°C	$\tau_{Rk,cr}$	[N/mm <sup>2</sup> ]	7,5	9,0	11	11	10	9,5	9,0	8,5	
Temperature range II:	55°C / 43°C	$\tau_{Rk,cr}$	[N/mm <sup>2</sup> ]	7,0	8,0	9,0	8,5	8,0	8,0	7,5	7,0	
Temperature range III:	75°C / 55°C	$\tau_{Rk,cr}$	[N/mm <sup>2</sup> ]	4,0	3,5	3,5	3,5	3,0	3,0	3,0	3,0	
<b>Influence factors <math>\psi</math> on bond resistance <math>\tau_{Rk}</math></b>												
Influence of concrete strength												
Cracked and uncracked concrete	in hammer drilled holes and hammer drilled holes with Hilti hollow drill bit TE-CD or TE-YD and diamond cored holes	$\psi_c$	C30/37	1,04								
			C40/50	1,07								
			C50/60	1,09								
	in diamond cored holes with roughening with Hilti Roughening tool TE-YRT	$\psi_c$	C30/37	2)	1,0							
			C40/50									
			C50/60									
Influence of sustained load												
Cracked and uncracked concrete	in hammer drilled holes and hammer drilled holes with hollow drill bit TE-CD or TE-YD and diamond cored holes with Hilti Roughening tool TE-YRT	$\psi_{sus}^0$	40°C / 24°C	0,88								
			55°C / 43°C	0,72								
			75°C / 55°C	0,69								
	diamond cored holes	$\psi_{sus}^0$	40°C / 24°C	0,89								
			55°C / 43°C	0,70								
			75°C / 55°C	0,62								

1) In absence of national regulations.

2) No performance assessed.

**Injection system Hilti HIT-RE 500 V4**

**Performances**

Essential characteristics under tension load in concrete

**Annex C2**

**Table C2: Characteristic resistance for threaded rods under tension load in concrete**

Threaded rod, HAS-..., HIT-V-..., size	[in.]	3/8	1/2	5/8	3/4	7/8	1	1 1/4	
<b>Steel failure</b>									
Characteristic resistance	$N_{Rk,s}$	[kN]	$A_s \cdot f_{uk}$						
Partial factor HIT-V	$\gamma_{Ms,N}^{1)}$	[-]	1,92						
Partial factor HAS-E-55	$\gamma_{Ms,N}^{1)}$	[-]	1,50						
Partial factor HAS-B-105	$\gamma_{Ms,N}^{1)}$	[-]	1,40						
Partial factor HAS-R 304	$\gamma_{Ms,N}^{1)}$	[-]	1,85		2,27				
Partial factor HAS-R 316	$\gamma_{Ms,N}^{1)}$	[-]	1,85		2,27				
<b>Installation factor</b>									
Hammer drilling	$\gamma_{inst}$	[-]	1,0						
Hammer drilling with Hilti hollow drill bit TE-CD or TE-YD	$\gamma_{inst}$	[-]	2)	1,0					
Diamond coring	$\gamma_{inst}$	[-]	1,2		1,4				
Diamond coring with roughening with Hilti Roughening tool TE-YRT	$\gamma_{inst}$	[-]	2)		1,0				
Hammer drilling in water-filled drill holes	$\gamma_{inst}$	[-]	1,4						
<b>Concrete cone failure</b>									
Factor for cracked concrete	$k_{Cr,N}$	[-]	7,7						
Factor for uncracked concrete	$k_{Ucr,N}$	[-]	11,0						
Edge distance	$c_{Cr,N}$	[mm]	$1,5 \cdot h_{ef}$						
Spacing	$s_{Cr,N}$	[mm]	$3,0 \cdot h_{ef}$						
<b>Splitting failure</b>									
Edge distance $c_{Cr,sp}$ [mm] for	$h / h_{ef} \geq 2,0$		$1,0 \cdot h_{ef}$						
	$2,0 > h / h_{ef} > 1,3$		$4,6 \cdot h_{ef} - 1,8 \cdot h$						
	$h / h_{ef} \leq 1,3$		$2,26 \cdot h_{ef}$						
Spacing	$s_{Cr,sp}$	[mm]	$2 \cdot c_{Cr,sp}$						
<b>Combined pullout and concrete cone failure</b>									
Characteristic resistance in uncracked concrete C20/25 in <b>hammer drilled holes</b> and <b>hammer drilled holes with Hilti hollow drill bit TE-CD or TE-YD</b> and <b>diamond cored holes with roughening with Hilti Roughening tool TE-YRT</b>									
Temperature range I: 40°C / 24°C	$\tau_{Rk,ucr}$	[N/mm <sup>2</sup> ]	19	18	17	16	16	15	14
Temperature range II: 55°C / 43°C	$\tau_{Rk,ucr}$	[N/mm <sup>2</sup> ]	15	15	14	14	13	12	11
Temperature range III: 75°C / 55°C	$\tau_{Rk,ucr}$	[N/mm <sup>2</sup> ]	6,0	6,0	5,5	5,5	5,0	5,0	4,5

**Injection system Hilti HIT-RE 500 V4**

**Performances**  
Essential characteristics under tension load in concrete

**Annex C3**

**Table C2: continued**

Threaded rod, HAS-U-..., HIT-V-..., AM...8.8, size [in.]				3/8	1/2	5/8	3/4	7/8	1	1 1/4	
Characteristic resistance in uncracked concrete C20/25 in <b>diamond cored holes</b>											
Temperature range I:	40°C / 24°C	$\tau_{RK,ucr}$	[N/mm <sup>2</sup> ]	13	13	13	12	12	12	12	
Temperature range II:	55°C / 43°C	$\tau_{RK,ucr}$	[N/mm <sup>2</sup> ]	12	11	11	11	11	11	10	
Temperature range III:	75°C / 55°C	$\tau_{RK,ucr}$	[N/mm <sup>2</sup> ]	5,5	5,5	5,5	5,5	5,5	5,5	5,0	
Characteristic resistance in uncracked concrete C20/25 in <b>hammer drilled holes and installation in water-filled drill holes</b>											
Temperature range I:	40°C / 24°C	$\tau_{RK,ucr}$	[N/mm <sup>2</sup> ]	16	15	15	14	13	13	12	
Temperature range II:	55°C / 43°C	$\tau_{RK,ucr}$	[N/mm <sup>2</sup> ]	13	13	12	12	11	11	9,5	
Temperature range III:	75°C / 55°C	$\tau_{RK,ucr}$	[N/mm <sup>2</sup> ]	5,0	5,0	4,5	4,5	4,5	4,0	3,5	
Characteristic resistance in cracked concrete C20/25 in <b>hammer drilled holes and hammer drilled holes with Hilti hollow drill bit TE-CD or TE-YD and diamond cored holes with roughening with Hilti Roughening tool TE-YRT</b>											
Temperature range I:	40°C / 24°C	$\tau_{RK,cr}$	[N/mm <sup>2</sup> ]	9,0	11	11	10	9,0	9,0	8,5	
Temperature range II:	55°C / 43°C	$\tau_{RK,cr}$	[N/mm <sup>2</sup> ]	8,0	9,0	8,5	8,5	8,0	7,5	7,0	
Temperature range III:	75°C / 55°C	$\tau_{RK,cr}$	[N/mm <sup>2</sup> ]	3,5	3,5	3,5	3,0	3,0	3,0	2,5	
<b>Influence factors <math>\psi</math> on bond resistance <math>\tau_{RK}</math></b>											
Influence of concrete strength											
Cracked and uncracked concrete	in hammer drilled holes and hammer drilled holes with Hilti hollow drill bit TE-CD or TE-YD and diamond cored holes	$\psi_c$	C30/37	1,04							
			C40/50	1,07							
			C50/60	1,09							
	in diamond cored holes with roughening with Hilti Roughening tool TE-YRT	$\psi_c$	C30/37	2)	1,0						
			C40/50								
			C50/60								
Influence of sustained load											
Cracked and uncracked concrete	in hammer drilled holes and hammer drilled holes with hollow drill bit TE-CD or TE-YD and diamond cored holes with Hilti Roughening tool TE-YRT	$\psi_{sus}^0$	40°C / 24°C	0,88							
			55°C / 43°C	0,72							
			75°C / 55°C	0,69							
	diamond cored holes	$\psi_{sus}^0$	40°C / 24°C	0,89							
			55°C / 43°C	0,70							
			75°C / 55°C	0,62							

1) In absence of national regulations.

2) No performance assessed.

**Injection system Hilti HIT-RE 500 V4**

**Performances**

Essential characteristics under tension load in concrete

**Annex C4**

**Table C3: Essential characteristics for internally threaded sleeve HIS-(R)N under tension load in concrete**

HIS-(R)N			M8	M10	M12	M16	M20
Outer diameter of sleeve	$d_{nom}$	[mm]	12,5	16,5	20,5	25,4	27,6
<b>Steel failure</b>							
Characteristic resistance HIS-N with screw grade 8.8	$N_{Rk,s}$	[kN]	25	46	67	125	116
Partial factor	$\gamma_{Ms,N}^{1)}$	[-]	1,5				
Characteristic resistance HIS-RN with screw grade 70	$N_{Rk,s}$	[kN]	26	41	59	110	166
Partial factor	$\gamma_{Ms,N}^{1)}$	[-]	1,87				2,4
<b>Installation factor</b>							
Hammer drilling	$\gamma_{inst}$	[-]	1,0				
Hammer drilling with Hilti hollow drill bit TE-CD or TE-YD	$\gamma_{inst}$	[-]	1,0				
Diamond coring	$\gamma_{inst}$	[-]	1,2	1,4			
Diamond coring with roughening with Hilti Roughening tool TE-YRT	$\gamma_{inst}$	[-]	2)	1,0			
Hammer drilling in water-filled drill holes	$\gamma_{inst}$	[-]	1,4				
<b>Concrete cone failure</b>							
Factor for cracked concrete	$k_{cr,N}$	[-]	7,7				
Factor for uncracked concrete	$k_{ucr,N}$	[-]	11,0				
Edge distance	$c_{cr,N}$	[mm]	$1,5 \cdot h_{ef}$				
Spacing	$s_{cr,N}$	[mm]	$3,0 \cdot h_{ef}$				
<b>Splitting failure</b>							
Edge distance $c_{cr,sp}$ [mm] for	$h / h_{ef} \geq 2,0$		$1,0 \cdot h_{ef}$				
	$2,0 > h / h_{ef} > 1,3$		$4,6 \cdot h_{ef} - 1,8 \cdot h$				
	$h / h_{ef} \leq 1,3$		$2,26 \cdot h_{ef}$				
Spacing	$s_{cr,sp}$	[mm]	$2 \cdot c_{cr,sp}$				
<b>Combined pullout and concrete cone failure <sup>3)</sup></b>							
Characteristic resistance in uncracked concrete C20/25 in hammer drilled holes and hammer drilled holes with Hilti hollow drill bit TE-CD or TE-YD and diamond cored holes with roughening with Hilti Roughening tool TE-YRT							
Temperature range I: 40°C / 24°C	$\tau_{Rk,ucr}$	[N/mm <sup>2</sup> ]	14	14	14	14	14
Temperature range II: 55°C / 43°C	$\tau_{Rk,ucr}$	[N/mm <sup>2</sup> ]	12	12	12	12	12
Temperature range III: 75°C / 55°C	$\tau_{Rk,ucr}$	[N/mm <sup>2</sup> ]	4,5	4,5	4,5	4,5	4,5

Injection system Hilti HIT-RE 500 V4

**Performances**  
Essential characteristics under tension load in concrete

Annex C5

**Table C3: continued**

HIS-(R)N				M8	M10	M12	M16	M20	
Characteristic resistance in uncracked concrete C20/25 in <b>diamond cored holes</b>									
Temperature range I:	40°C / 24°C	$\tau_{Rk,ucr}$	[N/mm <sup>2</sup> ]	8,5	9,0	9,5	10	10	
Temperature range II:	55°C / 43°C	$\tau_{Rk,ucr}$	[N/mm <sup>2</sup> ]	7,0	7,5	8,0	8,5	8,5	
Temperature range III:	75°C / 55°C	$\tau_{Rk,ucr}$	[N/mm <sup>2</sup> ]	4,0	4,5	4,5	4,5	4,5	
Characteristic resistance in uncracked concrete C20/25 in <b>hammer drilled holes and installation in water-filled drill holes</b>									
Temperature range I:	40°C / 24°C	$\tau_{Rk,ucr}$	[N/mm <sup>2</sup> ]	12	12	12	12	12	
Temperature range II:	55°C / 43°C	$\tau_{Rk,ucr}$	[N/mm <sup>2</sup> ]	10	10	10	10	10	
Temperature range III:	75°C / 55°C	$\tau_{Rk,ucr}$	[N/mm <sup>2</sup> ]	4,0	4,0	4,0	4,0	4,0	
Characteristic resistance in cracked concrete C20/25 in <b>hammer drilled holes and hammer drilled holes with Hilti hollow drill bit TE-CD or TE-YD</b> and <b>diamond cored holes with roughening with Hilti Roughening tool TE-YRT</b>									
Temperature range I:	40°C / 24°C	$\tau_{Rk,cr}$	[N/mm <sup>2</sup> ]	9,0	9,0	9,0	9,0	9,0	
Temperature range II:	55°C / 43°C	$\tau_{Rk,cr}$	[N/mm <sup>2</sup> ]	8,0	8,0	8,0	8,0	8,0	
Temperature range III:	75°C / 55°C	$\tau_{Rk,cr}$	[N/mm <sup>2</sup> ]	3,0	3,0	3,0	3,0	3,0	
<b>Influence factors <math>\psi</math> on bond resistance <math>\tau_{Rk}</math></b>									
Influence of concrete strength									
Cracked and uncracked concrete	in hammer drilled holes and hammer drilled holes with Hilti hollow drill bit TE-CD or TE-YD and diamond cored holes	$\psi_c$	C30/37	1,04					
			C40/50	1,07					
			C50/60	1,09					
	in diamond cored holes with roughening with Hilti Roughening tool TE-YRT	$\psi_c$	C30/37	2)	1,0				
			C40/50						
			C50/60						
Influence of sustained load									
Cracked and uncracked concrete	in hammer drilled holes and hammer drilled holes with hollow drill bit TE-CD or TE-YD and diamond cored holes with Hilti Roughening tool TE-YRT	$\psi_{sus}^0$	40°C / 24°C	0,88					
			55°C / 43°C	0,72					
			75°C / 55°C	0,69					
	diamond cored holes	$\psi_{sus}^0$	40°C / 24°C	0,89					
			55°C / 43°C	0,70					
			75°C / 55°C	0,62					

1) In absence of national regulations.

2) No performance assessed.

3) For design according to EN 1992-4:2018, the characteristic tension load values bond resistance may be calculated from the characteristic bond resistance for combined pull-out and concrete cone failure according to:  
 $N_{Rk} = \tau_{Rk} \cdot (h_{ef} \cdot d_{nom} \cdot \pi)$ .

**Injection system Hilti HIT-RE 500 V4**

**Performances**

Essential characteristics under tension load in concrete

**Annex C6**

**Table C4: Essential characteristics for internally threaded sleeve HIS-(R)N under tension load in concrete**

HIS-(R)N, size		[in.]	3/8	1/2	5/8	3/4
Outer diameter of sleeve	$d_{nom}$	[mm]	16,5	20,5	25,4	27,6
<b>Steel failure</b>						
Characteristic resistance HIS-N Screw acc. to SAE J429 Grade 5 or ASTM A325 (1/2 in. to 3/4 in.)	$N_{Rk,s}$	[kN]	41	76	121	130
Partial safety factor	$\gamma_{Ms,N}^{1)}$	[-]	1,57			1,50
Characteristic resistance HIS-N Screw acc. to ASTM A193 Grade B7	$N_{Rk,s}$	[kN]	43	77	128	130
Partial safety factor	$\gamma_{Ms,N}^{1)}$	[-]	1,43	1,50		
Characteristic resistance HIS-RN Screw acc. to ASTM A193 Grade B8M	$N_{Rk,s}$	[kN]	38	110	182	185
Partial safety factor	$\gamma_{Ms,N}^{1)}$	[-]	1,40	2,40		
Characteristic resistance HIS-RN Screw acc. to ASTM A193 Grade B8T	$N_{Rk,s}$	[kN]	43	110	182	185
Partial safety factor	$\gamma_{Ms,N}^{1)}$	[-]	1,50	2,40		
<b>Installation factor</b>						
Hammer drilling	$\gamma_{inst}$	[-]	1,0			
Hammer drilling with Hilti hollow drill bit TE-CD or TE-YD	$\gamma_{inst}$	[-]	3)	1,0		3)
Diamond coring	$\gamma_{inst}$	[-]	1,4			
Diamond coring with roughening with Hilti Roughening tool TE-YRT	$\gamma_{inst}$	[-]	3)	1,0		3)
Hammer drilling in water-filled drill holes	$\gamma_{inst}$	[-]	1,4			
<b>Concrete cone failure</b>						
Factor for cracked concrete	$k_{cr,N}$	[-]	7,7			
Factor for uncracked concrete	$k_{ucr,N}$	[-]	11,0			
Edge distance	$c_{cr,N}$	[mm]	$1,5 \cdot h_{ef}$			
Spacing	$s_{cr,N}$	[mm]	$3,0 \cdot h_{ef}$			
<b>Splitting failure</b>						
Edge distance $c_{cr,sp}$ [mm] for	$h / h_{ef} \geq 2,0$		$1,0 \cdot h_{ef}$			
	$2,0 > h / h_{ef} > 1,3$		$4,6 \cdot h_{ef} - 1,8 \cdot h$			
	$h / h_{ef} \leq 1,3$		$2,26 \cdot h_{ef}$			
Spacing	$s_{cr,sp}$	[mm]	$2 \cdot c_{cr,sp}$			

Injection system Hilti HIT-RE 500 V4

**Performances**  
Essential characteristics under tension load in concrete

Annex C7

**Table C4: continued (1)**

HIS-(R)N, size	[in.]	3/8	1/2	5/8	3/4
<b>Combined pullout and concrete cone failure <sup>2)</sup></b>					
Characteristic resistance in uncracked concrete C20/25 in <b>hammer drilled holes</b> and <b>hammer drilled holes with Hilti hollow drill bit TE-CD or TE-YD</b> and <b>diamond cored holes with roughening with Hilti Roughening tool TE-YRT</b>					
Temperature range I: 40°C / 24°C	$\tau_{Rk,ucr}$ [N/mm <sup>2</sup> ]	14	14	14	14
Temperature range II: 55°C / 43°C	$\tau_{Rk,ucr}$ [N/mm <sup>2</sup> ]	12	12	12	12
Temperature range III: 75°C / 55°C	$\tau_{Rk,ucr}$ [N/mm <sup>2</sup> ]	4,5	4,5	4,5	4,5
Characteristic resistance in uncracked concrete C20/25 in <b>diamond cored holes</b>					
Temperature range I: 40°C / 24°C	$\tau_{Rk,ucr}$ [N/mm <sup>2</sup> ]	9,0	9,5	10	10
Temperature range II: 55°C / 43°C	$\tau_{Rk,ucr}$ [N/mm <sup>2</sup> ]	7,5	8,0	8,5	8,5
Temperature range III: 75°C / 55°C	$\tau_{Rk,ucr}$ [N/mm <sup>2</sup> ]	4,5	4,5	4,5	4,5
Characteristic resistance in uncracked concrete C20/25 in <b>hammer drilled holes and installation in water-filled drill holes</b>					
Temperature range I: 40°C / 24°C	$\tau_{Rk,ucr}$ [N/mm <sup>2</sup> ]	12	12	12	12
Temperature range II: 55°C / 43°C	$\tau_{Rk,ucr}$ [N/mm <sup>2</sup> ]	10	10	10	10
Temperature range III: 75°C / 55°C	$\tau_{Rk,ucr}$ [N/mm <sup>2</sup> ]	4,0	4,0	4,0	4,0
Characteristic resistance in cracked concrete C20/25 in <b>hammer drilled holes</b> and <b>hammer drilled holes with Hilti hollow drill bit TE-CD or TE-YD</b> and <b>diamond cored holes with roughening with Hilti Roughening tool TE-YRT</b>					
Temperature range I: 40°C / 24°C	$\tau_{Rk,cr}$ [N/mm <sup>2</sup> ]	9,0	9,0	9,0	9,0
Temperature range II: 55°C / 43°C	$\tau_{Rk,cr}$ [N/mm <sup>2</sup> ]	8,0	8,0	8,0	8,0
Temperature range III: 75°C / 55°C	$\tau_{Rk,cr}$ [N/mm <sup>2</sup> ]	3,0	3,0	3,0	3,0

**Injection system Hilti HIT-RE 500 V4**

**Performances**

Essential characteristics under tension load in concrete

**Annex C8**

**Table C4: continued (2)**

HIS-(R)N, size		[in.]	3/8	1/2	5/8	3/4
<b>Influence factors <math>\psi</math> on bond resistance <math>\tau_{Rk}</math></b>						
Influence of concrete strength						
Cracked and uncracked concrete	in hammer drilled holes and hammer drilled holes with Hilti hollow drill bit TE-CD or TE-YD and diamond cored holes	$\psi_c$	C30/37	1,04		
			C40/50	1,07		
			C50/60	1,09		
	in diamond cored holes with roughening with Hilti Roughening tool TE-YRT	$\psi_c$	C30/37	3)	1,0	3)
			C40/50			
			C50/60			
Influence of sustained load						
Cracked and uncracked concrete	in hammer drilled holes and hammer drilled holes with hollow drill bit TE-CD or TE-YD and diamond cored holes with Hilti Roughening tool TE-YRT	$\psi_{sus}^0$	40°C / 24°C	0,88		
			55°C / 43°C	0,72		
			75°C / 55°C	0,69		
	diamond cored holes	$\psi_{sus}^0$	40°C / 24°C	0,89		
			55°C / 43°C	0,70		
			75°C / 55°C	0,62		

1) In absence of national regulations.

2) For design according to EN 1992-4:2018, the characteristic tension load values bond resistance may be calculated from the characteristic bond resistance for combined pull-out and concrete cone failure according to:

$$N_{Rk} = \tau_{Rk} \cdot (h_{ef} \cdot d_{nom} \cdot \pi).$$

3) No performance assessed.

**Injection system Hilti HIT-RE 500 V4**

**Performances**

Essential characteristics under tension load in concrete

**Annex C9**

**Table C5: Essential characteristics for Hilti tension anchor HZA / HZA-R under tension load in concrete**

HZA / HZA-R			M12	M16	M20	M24	M27	
Rebar diameter	$\phi$	[mm]	12	16	20	25	28	
<b>Steel failure</b>								
Characteristic resistance HZA	$N_{Rk,s}$	[kN]	46	86	135	194	252	
Characteristic resistance HZA-R	$N_{Rk,s}$	[kN]	62	111	173	249	1)	
Partial factor	$\gamma_{Ms,N}^{2)}$	[-]	1,4					
<b>Installation factor</b>								
Hammer drilling	$\gamma_{inst}$	[-]	1,0					
Hammer drilling with Hilti hollow drill bit TE-CD or TE-YD	$\gamma_{inst}$	[-]	1,0					
Diamond coring	$\gamma_{inst}$	[-]	1,2	1,4				
Diamond coring with roughening with Hilti Roughening tool TE-YRT	$\gamma_{inst}$	[-]	1)	1,0				
Hammer drilling in water-filled drill holes	$\gamma_{inst}$	[-]	1,4					
<b>Concrete cone failure</b>								
Effective embedment depth	$h_{ef}$	[mm]	$h_{nom}$					
Factor for cracked concrete	$k_{cr,N}$	[-]	7,7					
Factor for uncracked concrete	$k_{ucr,N}$	[-]	11,0					
Edge distance	$c_{cr,N}$	[mm]	$1,5 \cdot h_{ef}$					
Spacing	$s_{cr,N}$	[mm]	$3,0 \cdot h_{ef}$					
<b>Splitting failure</b>								
Edge distance $c_{cr,sp}$ [mm] for	$h / h_{ef} \geq 2,0$		$1,0 \cdot h_{ef}$					
	$2,0 > h / h_{ef} > 1,3$		$4,6 \cdot h_{ef} - 1,8 \cdot h$					
	$h / h_{ef} \leq 1,3$		$2,26 \cdot h_{ef}$					
Spacing	$s_{cr,sp}$	[mm]	$2 \cdot c_{cr,sp}$					
<b>Combined pullout and concrete cone failure</b>								
Effective embedment depth	HZA	$h_{ef}$	[mm]	$h_{nom} - 20$				
	HZA-R	$h_{ef}$	[mm]	$h_{nom} - 100$				1)
Characteristic resistance in uncracked concrete C20/25 in <b>hammer drilled holes</b> and <b>hammer drilled holes with Hilti hollow drill bit TE-CD or TE-YD</b> and <b>diamond cored holes with roughening with Hilti Roughening tool TE-YRT</b>								
Temperature range I:	40°C / 24°C	$\tau_{Rk,ucr}$	[N/mm <sup>2</sup> ]	15	15	14	14	14
Temperature range II:	55°C / 43°C	$\tau_{Rk,ucr}$	[N/mm <sup>2</sup> ]	12	12	12	11	11
Temperature range III:	75°C / 55°C	$\tau_{Rk,ucr}$	[N/mm <sup>2</sup> ]	5,0	4,5	4,5	4,5	4,5

Injection system Hilti HIT-RE 500 V4

**Performances**  
Essential characteristics under tension load in concrete

Annex C10

**Table C5: continued**

HZA / HZA-R				M12	M16	M20	M24	M27	
Rebar diameter	$\phi$	[mm]		12	16	20	25	28	
Characteristic resistance in uncracked concrete C20/25 in <b>diamond cored holes</b>									
Temperature range I:	40°C / 24°C	$\tau_{Rk,ucr}$	[N/mm <sup>2</sup> ]	9,5	9,5	9,5	9,5	10	
Temperature range II:	55°C / 43°C	$\tau_{Rk,ucr}$	[N/mm <sup>2</sup> ]	7,5	8,0	8,0	8,0	8,0	
Temperature range III:	75°C / 55°C	$\tau_{Rk,ucr}$	[N/mm <sup>2</sup> ]	4,5	5,0	5,0	5,0	5,0	
Characteristic resistance in uncracked concrete C20/25 in <b>hammer drilled holes and installation in water-filled drill holes</b>									
Temperature range I:	40°C / 24°C	$\tau_{Rk,ucr}$	[N/mm <sup>2</sup> ]	13	12	12	12	12	
Temperature range II:	55°C / 43°C	$\tau_{Rk,ucr}$	[N/mm <sup>2</sup> ]	11	10	10	10	9,5	
Temperature range III:	75°C / 55°C	$\tau_{Rk,ucr}$	[N/mm <sup>2</sup> ]	4,0	4,0	4,0	4,0	3,5	
Characteristic resistance in cracked concrete C20/25 in <b>hammer drilled holes and hammer drilled holes with Hilti hollow drill bit TE-CD or TE-YD and diamond cored holes with roughening with Hilti Roughening tool TE-YRT</b>									
Temperature range I:	40°C / 24°C	$\tau_{Rk,cr}$	[N/mm <sup>2</sup> ]	12	12	12	11	11	
Temperature range II:	55°C / 43°C	$\tau_{Rk,cr}$	[N/mm <sup>2</sup> ]	10	10	10	9,5	9,5	
Temperature range III:	75°C / 55°C	$\tau_{Rk,cr}$	[N/mm <sup>2</sup> ]	4,0	5,0	5,0	4,5	4,5	
<b>Influence factors <math>\psi</math> on bond resistance <math>\tau_{RK}</math></b>									
Influence of concrete strength									
Cracked and uncracked concrete	in hammer drilled holes and hammer drilled holes with Hilti hollow drill bit TE-CD or TE-YD and diamond cored holes	$\psi_c$	C30/37	1,04					
			C40/50	1,07					
			C50/60	1,09					
	in diamond cored holes with roughening with Hilti Roughening tool TE-YRT	$\psi_c$	C30/37	1)	1,0				
			C40/50						
			C50/60						
Influence of sustained load									
Cracked and uncracked concrete	in hammer drilled holes and hammer drilled holes with hollow drill bit TE-CD or TE-YD and diamond cored holes with Hilti Roughening tool TE-YRT	$\psi_{sus}^0$	40°C / 24°C	0,88					
			55°C / 43°C	0,72					
			75°C / 55°C	0,69					
	diamond cored holes	$\psi_{sus}^0$	40°C / 24°C	0,89					
			55°C / 43°C	0,70					
			75°C / 55°C	0,62					

1) No performance assessed.

2) In absence of national regulations.

**Injection system Hilti HIT-RE 500 V4**

**Performances**

Essential characteristics under tension load in concrete

**Annex C11**

**Table C6: Essential characteristics for reinforcing bars (rebars) under tension load in concrete**

Reinforcing bar (rebar)	φ 8	φ 10	φ 12	φ 14	φ 16	φ 20	φ 25	φ 28	φ 30	φ 32	
<b>Steel failure</b>											
Characteristic resistance Rebar B500B acc. to DIN 488:2009-08 <sup>1)</sup> $N_{Rk,s}$ [kN]	28	43	62	85	111	173	270	339	388	442	
Partial factor <sup>2)</sup> $\gamma_{Ms,N}$ <sup>3)</sup> [-]	1,4										
<b>Installation factor</b>											
Hammer drilling $\gamma_{inst}$ [-]	1,0										
Hammer drilling with Hilti hollow drill bit TE-CD or TE-YD $\gamma_{inst}$ [-]	<sup>4)</sup>	1,0							<sup>4)</sup>		
Diamond coring $\gamma_{inst}$ [-]	1,2					1,4					
Diamond coring with roughening with Hilti Roughening tool TE-YRT $\gamma_{inst}$ [-]	<sup>4)</sup>	1,0					<sup>4)</sup>				
Hammer drilling in water-filled drill holes $\gamma_{inst}$ [-]	1,4										
<b>Concrete cone failure</b>											
Factor for cracked concrete $k_{cr,N}$ [-]	7,7										
Factor for uncracked concrete $k_{ucr,N}$ [-]	11,0										
Edge distance $c_{cr,N}$ [mm]	$1,5 \cdot h_{ef}$										
Spacing $s_{cr,N}$ [mm]	$3,0 \cdot h_{ef}$										
<b>Splitting failure</b>											
Edge distance $c_{cr,sp}$ [mm] for	$h / h_{ef} \geq 2,0$	$1,0 \cdot h_{ef}$									
	$2,0 > h / h_{ef} > 1,3$	$4,6 \cdot h_{ef} - 1,8 \cdot h$									
	$h / h_{ef} \leq 1,3$	$2,26 \cdot h_{ef}$									
Spacing $s_{cr,sp}$ [mm]	$2 \cdot c_{cr,sp}$										
<b>Combined pullout and concrete cone failure</b>											
Characteristic resistance in uncracked concrete C20/25 in <b>hammer drilled holes</b> and <b>hammer drilled holes with Hilti hollow drill bit TE-CD or TE-YD</b> and <b>diamond cored holes with roughening with Hilti Roughening tool TE-YRT</b>											
Temperature range I: 40°C / 24°C $\tau_{Rk,ucr}$ [N/mm <sup>2</sup> ]	10	15	15	15	15	14	14	14	13	13	
Temperature range II: 55°C / 43°C $\tau_{Rk,ucr}$ [N/mm <sup>2</sup> ]	8,5	13	12	12	12	12	11	11	11	11	
Temperature range III: 75°C / 55°C $\tau_{Rk,ucr}$ [N/mm <sup>2</sup> ]	3,5	5,0	5,0	5,0	4,5	4,5	4,5	4,5	4,5	4,5	
Characteristic resistance in uncracked concrete C20/25 in <b>diamond cored holes</b>											
Temperature range I: 40°C / 24°C $\tau_{Rk,ucr}$ [N/mm <sup>2</sup> ]	9,5	9,5	9,5	9,5	9,5	9,5	9,5	10	10	10	
Temperature range II: 55°C / 43°C $\tau_{Rk,ucr}$ [N/mm <sup>2</sup> ]	7,5	7,5	7,5	8,0	8,0	8,0	8,0	8,0	8,0	8,0	
Temperature range III: 75°C / 55°C $\tau_{Rk,ucr}$ [N/mm <sup>2</sup> ]	3,0	4,5	4,5	4,5	5,0	5,0	5,0	5,0	5,0	5,0	

Injection system Hilti HIT-RE 500 V4

**Performances**  
Essential characteristics under tension load in concrete

**Annex C12**

**Table C6: continued**

Reinforcing bar (rebar)				φ 8	φ 10	φ 12	φ 14	φ 16	φ 20	φ 25	φ 28	φ 30	φ 32
Characteristic resistance in uncracked concrete C20/25 in hammer drilled holes and installation in water-filled drill holes													
Temperature range I:	40°C / 24°C	$\tau_{Rk,ucr}$	[N/mm <sup>2</sup> ]	8,5	13	13	13	12	12	12	12	11	11
Temperature range II:	55°C / 43°C	$\tau_{Rk,ucr}$	[N/mm <sup>2</sup> ]	7,0	11	11	10	10	10	10	9,5	9,5	9,5
Temperature range III:	75°C / 55°C	$\tau_{Rk,ucr}$	[N/mm <sup>2</sup> ]	3,0	4,0	4,0	4,0	4,0	4,0	4,0	3,5	3,5	3,5
Characteristic resistance in cracked concrete C20/25 in hammer drilled holes and hammer drilled holes with Hilti hollow drill bit TE-CD or TE-YD and diamond cored holes with roughening with Hilti Roughening tool TE-YRT													
Temperature range I:	40°C / 24°C	$\tau_{Rk,cr}$	[N/mm <sup>2</sup> ]	5,5	10	12	12	12	12	11	11	11	11
Temperature range II:	55°C / 43°C	$\tau_{Rk,cr}$	[N/mm <sup>2</sup> ]	5,0	8,5	10	10	10	10	9,5	9,5	9,5	9,0
Temperature range III:	75°C / 55°C	$\tau_{Rk,cr}$	[N/mm <sup>2</sup> ]	2,0	4,0	4,0	5,0	5,0	5,0	4,5	4,5	4,5	4,5
<b>Influence factors <math>\psi</math> on bond resistance <math>\tau_{Rk}</math></b>													
Influence of concrete strength													
Cracked and uncracked concrete	in hammer drilled holes and hammer drilled holes with Hilti hollow drill bit TE-CD or TE-YD and diamond cored holes	$\psi_c$	C30/37	1,04									
			C40/50	1,07									
			C50/60	1,09									
	in diamond cored holes with roughening with Hilti Roughening tool TE-YRT	$\psi_c$	C30/37	4)	1,0								4)
			C40/50										
			C50/60										
Influence of sustained load													
Cracked and uncracked concrete	in hammer drilled holes and hammer drilled holes with hollow drill bit TE-CD or TE-YD and diamond cored holes with Hilti Roughening tool TE-YRT	$\psi_{sus}^0$	40°C / 24°C	0,88									
			55°C / 43°C	0,72									
			75°C / 55°C	0,69									
	diamond cored holes	$\psi_{sus}^0$	40°C / 24°C	0,89									
			55°C / 43°C	0,70									
			75°C / 55°C	0,62									

1) Values need to be calculated acc. EAD 330499-01, Eq. 2.1, if rebars do not fulfil the requirements acc. DIN 488.

3) Values need to be calculated acc. EN 1992-4:2018, tab 4.1, if rebars do not fulfil the requirements acc. DIN 488.

2) In absence of national regulations.

4) No performance assessed.

**Injection system Hilti HIT-RE 500 V4**

**Performances**

Essential characteristics under tension load in concrete

**Annex C13**

**Table C7: Essential characteristics for threaded rods under shear load in concrete**

Threaded rod, HAS-U-..., HIT-V-..., AM...8.8			M8	M10	M12	M16	M20	M24	M27	M30		
<b>Steel failure without lever arm</b>												
Characteristic resistance	$V^0_{Rk,s}$	[kN]	0,5 · A <sub>s</sub> · f <sub>uk</sub>									
Partial factor grade 5.8, 8.8	$\gamma_{Ms,v}$ <sup>1)</sup>	[-]	1,25									
Partial factor HAS-U A4, HIT-V-R	$\gamma_{Ms,v}$ <sup>1)</sup>	[-]	1,56						2,38			
Partial factor HAS-U HCR, HIT-V-HCR	$\gamma_{Ms,v}$ <sup>1)</sup>	[-]	1,25					1,75				
Ductility factor	k <sub>7</sub>	[-]	1,0									
<b>Steel failure with lever arm</b>												
Characteristic resistance	$M^0_{Rk,s}$	[Nm]	1,2 · W <sub>el</sub> · f <sub>uk</sub>									
Ductility factor	k <sub>7</sub>	[-]	1,0									
<b>Concrete pry-out failure</b>												
Pry-out factor	k <sub>8</sub>	[-]	2,0									
<b>Concrete edge failure</b>												
Effective length of fastener	l <sub>f</sub>	[mm]	min (h <sub>ef</sub> ; 12 · d <sub>nom</sub> ; 300)									
Outside diameter of the anchor	d <sub>nom</sub>	[mm]	8	10	12	16	20	24	27	30		

<sup>1)</sup> In absence of national regulations.

**Table C8: Essential characteristics for threaded rods under shear load in concrete**

Threaded rod, HAS-..., HIT-V-..., size			[in.]	3/8	1/2	5/8	3/4	7/8	1	1 1/4	
<b>Steel failure without lever arm</b>											
Characteristic resistance	$V^0_{Rk,s}$	[kN]	0,5 · A <sub>s</sub> · f <sub>uk</sub>								
Partial factor HIT-V	$\gamma_{Ms,v}$ <sup>1)</sup>		1,60								
Partial factor HAS-E-55	$\gamma_{Ms,v}$ <sup>1)</sup>	[-]	1,25								
Partial factor HAS-B-105	$\gamma_{Ms,v}$ <sup>1)</sup>	[-]	1,50								
Partial factor HAS-R 304	$\gamma_{Ms,v}$ <sup>1)</sup>	[-]	1,54				1,89				
Partial factor HAS-R 316	$\gamma_{Ms,v}$ <sup>1)</sup>	[-]	1,54				1,89				
Ductility factor	k <sub>7</sub>	[-]	1,0								
<b>Steel failure with lever arm</b>											
Characteristic resistance	$M^0_{Rk,s}$	[Nm]	1,2 · W <sub>el</sub> · f <sub>uk</sub>								
<b>Concrete pry-out failure</b>											
Pry-out factor	k <sub>8</sub>	[-]	2,0								
<b>Concrete edge failure</b>											
Effective length of fastener	l <sub>f</sub>	[mm]	min (h <sub>ef</sub> ; 12 · d <sub>nom</sub> ; 300)								
Outside diameter of the anchor	d <sub>nom</sub>	[mm]	9,5	12,7	15,9	19,1	22,2	25,4	31,8		

<sup>1)</sup> In absence of national regulations.

**Injection system Hilti HIT-RE 500 V4**

**Performances**  
Essential characteristics under shear load in concrete

**Annex C14**

**Table C9: Essential characteristics for internally threaded sleeve HIS-(R)N under shear load in concrete**

HIS-(R)N			M8	M10	M12	M16	M20
<b>Steel failure without lever arm</b>							
Characteristic resistance HIS-N with screw grade 8.8	$V_{Rk,s}^0$	[kN]	13	23	34	63	58
Partial factor	$\gamma_{Ms,v}^{1)}$	[-]	1,25				
Characteristic resistance HIS-RN with screw grade 70	$V_{Rk,s}$	[kN]	13	20	30	55	83
Partial factor	$\gamma_{Ms,v}^{1)}$	[-]	1,56				
Ductility factor	$k_7$	[-]	1,0				
<b>Steel failure with lever arm</b>							
Characteristic resistance HIS-N	$M_{Rk,s}^0$	[Nm]	30	60	105	266	519
Partial factor	$\gamma_{Ms,v}^{1)}$	[-]	1,25				
Characteristic resistance HIS-RN	$M_{Rk,s}^0$	[Nm]	26	52	92	233	454
Partial factor	$\gamma_{Ms,v}^{1)}$	[-]	1,56				
Ductility factor	$k_7$	[-]	1,0				
<b>Concrete pry-out failure</b>							
Pry-out factor	$k_8$	[-]	2,0				
<b>Concrete edge failure</b>							
Effective length of fastener	$l_f$	[mm]	90	110	125	170	205
Outside diameter of the anchor	$d_{nom}$	[mm]	12,5	16,5	20,5	25,4	27,6

<sup>1)</sup> In absence of national regulations.

**Injection system Hilti HIT-RE 500 V4**

**Performances**  
 Essential characteristics under shear load in concrete

**Annex C15**

**Table C10: Essential characteristics for internally threaded sleeve HIS-(R)N under shear load in concrete**

HIS-(R)N, size	[in.]	3/8	1/2	5/8	3/4
<b>Steel failure without lever arm</b>					
Characteristic resistance HIS-N Screw acc. to SAE J429 Grade 5 or ASTM A325 (1/2 in. to 3/4 in.)	$V^0_{Rk,s}$ [kN]	21	38	60	65
Partial safety factor	$\gamma_{Ms,v}^{1)}$ [-]	1,50			1,25
Characteristic resistance HIS-N Screw acc. to ASTM A193 Grade B7	$V^0_{Rk,s}$ [kN]	22	40	63	65
Partial safety factor	$\gamma_{Ms,v}^{1)}$ [-]	1,50			1,25
Characteristic resistance HIS-RN Screw acc. to ASTM A193 Grade B8M (AISI 316)	$V^0_{Rk,s}$ [kN]	19	35	55	93
Partial safety factor	$\gamma_{Ms,v}^{1)}$ [-]	1,50			2,00
Characteristic resistance HIS-RN Screw acc. to ASTM A193 Grade B8T (AISI 321)	$V^0_{Rk,s}$ [kN]	22	40	63	93
Partial safety factor	$\gamma_{Ms,v}^{1)}$ [-]	1,50			2,00
Ductility factor	$k_7$ [-]	1,0			
<b>Steel failure with lever arm</b>					
Characteristic resistance HIS-N Screw acc. to SAE J429 Grade 5 or ASTM A325 (1/2 in. to 3/4 in.)	$M^0_{Rk,s}$ [Nm]	50	123	247	444
Characteristic resistance HIS-N Screw acc. to ASTM A193 Grade B7	$M^0_{Rk,s}$ [Nm]	52	128	257	463
Characteristic resistance HIS-RN Screw acc. to ASTM A193 Grade B8M (AISI 316)	$M^0_{Rk,s}$ [Nm]	45	113	226	407
Characteristic resistance HIS-RN Screw acc. to ASTM A193 Grade B8T (AISI 321)	$M^0_{Rk,s}$ [Nm] ([ft-lb])	52	128	257	463
Partial safety factor	$\gamma_{Ms,v}^{1)}$ [-]	1,50			
<b>Concrete pryout failure</b>					
Pry-out factor	$k_8$ [-]	2,0			
<b>Concrete edge failure</b>					
Effective length of fastener	$l_f$ [mm]	110	125	170	205
Outside diameter of the anchor	$d_{nom}$ [mm]	16,5	20,5	25,4	27,6

<sup>1)</sup> In absence of national regulations.

**Injection system Hilti HIT-RE 500 V4**

**Performances**  
Essential characteristics under shear load in concrete

**Annex C16**

**Table C11: Essential characteristics for Hilti tension anchor HZA / HZA-R under shear load in concrete**

HZA / HZA-R			M12	M16	M20	M24	M27
Rebar diameter	$\phi$	[mm]	12	16	20	25	28
<b>Steel failure without lever arm</b>							
Characteristic resistance HZA	$V_{Rk,s}^0$	[kN]	23	43	67	97	126
Characteristic resistance HZA-R	$V_{Rk,s}^0$	[kN]	31	55	86	124	<sup>2)</sup>
Partial factor	$\gamma_{Ms,v}^{1)}$	[-]	1,5				
Ductility factor	$k_7$	[-]	1,0				
<b>Steel failure with lever arm</b>							
Characteristic resistance HZA	$M_{Rk,s}^0$	[Nm]	72	183	357	617	915
Characteristic resistance HZA-R	$M_{Rk,s}^0$	[Nm]	97	234	458	790	<sup>2)</sup>
Partial factor	$\gamma_{Ms,v}^{1)}$	[-]	1,5				
Ductility factor	$k_7$	[-]	1,0				
<b>Concrete pryout failure</b>							
Pry-out factor	$k_8$	[-]	2.0				
<b>Concrete edge failure</b>							
Effective length of fastener	$l_f$	[mm]	min ( $h_{ef}$ ; $12 \cdot d_{nom}$ ; 300)				
Outside diameter of the anchor	$d_{nom}$	[mm]	12	16	20	24	27

<sup>1)</sup> In absence of national regulations.

<sup>2)</sup> No performance assessed.

Injection system Hilti HIT-RE 500 V4

**Performances**

Essential characteristics under shear load in concrete

Annex C17

**Table C12: Essential characteristics for reinforcing bars (rebars) under shear load in concrete**

Reinforcing bar (rebar)		φ 8	φ 10	φ 12	φ 14	φ 16	φ 20	φ 25	φ 28	φ 30	φ 32
<b>Steel failure without lever arm</b>											
Characteristic resistance Rebar B500B acc. to DIN 488:2009-08 <sup>2)</sup>	$V^0_{Rk,s}$ [kN]	14	22	31	42	55	86	135	169	194	221
Partial factor <sup>3)</sup>	$\gamma_{Ms,v}$ <sup>1)</sup> [-]	1,5									
Ductility factor	$k_7$ [-]	1,0									
<b>Steel failure with lever arm</b>											
Rebar B500B acc. to DIN 488:2009-08 <sup>2)</sup>	$M^0_{Rk,s}$ [Nm]	33	65	112	178	265	518	1012	1422	1749	2123
Partial factor <sup>3)</sup>	$\gamma_{Ms,v}$ <sup>1)</sup> [-]	1,5									
Ductility factor	$k_7$ [-]	1,0									
<b>Concrete pry-out failure</b>											
Pry-out factor	$k_8$ [-]	2,0									
<b>Concrete edge failure</b>											
Effective length of fastener	$l_f$ [mm]	min ( $h_{ef}$ ; $12 \cdot d_{nom}$ , 300)									
Outside diameter of the anchor	$d_{nom}$ [mm]	8	10	12	14	16	20	25	28	30	32

<sup>1)</sup> In absence of national regulations.

<sup>2)</sup> Values need to be calculated acc. EAD 330499-01, Eq. 2.1, if rebars do not fulfil requirements acc. DIN 488.

<sup>3)</sup> Values need to be calculated acc. EN 1992-4:2018, Tab 4.1, if rebars do not fulfil requirements acc. DIN 488.

**Injection system Hilti HIT-RE 500 V4**

**Performances**

Essential characteristics under shear load in concrete

**Annex C18**

**Table C13: Displacements for threaded rods under tension load in concrete**

Threaded rod, HAS-U-..., HIT-V-..., AM...8.8			M8	M10	M12	M16	M20	M24	M27	M30
Threaded rod, HAS-..., HIT-V-..., size			-	3/8	1/2	5/8	3/4	7/8	1	1 1/4
Displacement in uncracked concrete										
Temperature range I: 40°C / 24°C	$\delta_{N0}$	[mm/(N/mm <sup>2</sup> )]	0,04	0,05	0,05	0,06	0,06	0,07	0,08	0,08
	$\delta_{N\infty}$	[mm/(N/mm <sup>2</sup> )]	0,10	0,11	0,12	0,13	0,15	0,17	0,18	0,19
Temperature range II: 55°C / 43°C	$\delta_{N0}$	[mm/(N/mm <sup>2</sup> )]	0,05	0,05	0,06	0,07	0,07	0,08	0,09	0,10
	$\delta_{N\infty}$	[mm/(N/mm <sup>2</sup> )]	0,12	0,13	0,14	0,16	0,18	0,20	0,21	0,23
Temperature range III: 75°C / 55°C	$\delta_{N0}$	[mm/(N/mm <sup>2</sup> )]	0,05	0,06	0,06	0,07	0,08	0,09	0,09	0,10
	$\delta_{N\infty}$	[mm/(N/mm <sup>2</sup> )]	0,12	0,13	0,15	0,17	0,19	0,21	0,23	0,24
Displacement in cracked concrete										
Temperature range I: 40°C / 24°C	$\delta_{N0}$	[mm/(N/mm <sup>2</sup> )]	0,02	0,03	0,05	0,08	0,10	0,13	0,15	0,18
	$\delta_{N\infty}$	[mm/(N/mm <sup>2</sup> )]	0,12	0,19	0,14	0,19	0,16	0,16	0,15	0,18
Temperature range II: 55°C / 43°C	$\delta_{N0}$	[mm/(N/mm <sup>2</sup> )]	0,02	0,04	0,06	0,09	0,12	0,16	0,18	0,21
	$\delta_{N\infty}$	[mm/(N/mm <sup>2</sup> )]	0,15	0,23	0,17	0,23	0,19	0,19	0,18	0,21
Temperature range III: 75°C / 55°C	$\delta_{N0}$	[mm/(N/mm <sup>2</sup> )]	0,02	0,04	0,06	0,10	0,13	0,17	0,19	0,22
	$\delta_{N\infty}$	[mm/(N/mm <sup>2</sup> )]	0,16	0,24	0,18	0,24	0,20	0,20	0,19	0,22

**Table C14: Displacements for internally threaded HIS-(R)N under tension load in concrete**

HIS-(R)N		M8	M10	M12	M16	M20	
HIS-(R)N, size [in.]		-	3/8	1/2	5/8	3/4	
Displacement in uncracked concrete							
Temperature range I: 40°C / 24°C	$\delta_{N0}$	[mm/(N/mm <sup>2</sup> )]	0,05	0,06	0,06	0,07	0,08
	$\delta_{N\infty}$	[mm/(N/mm <sup>2</sup> )]	0,12	0,13	0,15	0,17	0,18
Temperature range II: 55°C / 43°C	$\delta_{N0}$	[mm/(N/mm <sup>2</sup> )]	0,06	0,07	0,07	0,08	0,09
	$\delta_{N\infty}$	[mm/(N/mm <sup>2</sup> )]	0,14	0,16	0,18	0,20	0,21
Temperature range III: 75°C / 55°C	$\delta_{N0}$	[mm/(N/mm <sup>2</sup> )]	0,06	0,07	0,07	0,09	0,10
	$\delta_{N\infty}$	[mm/(N/mm <sup>2</sup> )]	0,15	0,16	0,19	0,21	0,22
Displacement in cracked concrete							
Temperature range I: 40°C / 24°C	$\delta_{N0}$	[mm/(N/mm <sup>2</sup> )]	0,02	0,03	0,05	0,08	0,10
	$\delta_{N\infty}$	[mm/(N/mm <sup>2</sup> )]	0,12	0,19	0,14	0,19	0,16
Temperature range II: 55°C / 43°C	$\delta_{N0}$	[mm/(N/mm <sup>2</sup> )]	0,02	0,04	0,06	0,09	0,12
	$\delta_{N\infty}$	[mm/(N/mm <sup>2</sup> )]	0,15	0,23	0,17	0,23	0,19
Temperature range III: 75°C / 55°C	$\delta_{N0}$	[mm/(N/mm <sup>2</sup> )]	0,02	0,04	0,06	0,10	0,13
	$\delta_{N\infty}$	[mm/(N/mm <sup>2</sup> )]	0,16	0,24	0,18	0,24	0,20

**Injection system Hilti HIT-RE 500 V4**

**Performances**  
Displacements under tension load in concrete

**Annex C19**

**Table C15: Displacements for Hilti tension anchor HZA / HZA-R under tension load in concrete**

HZA / HZA-R		M12	M16	M20	M24	M27
Rebar diameter	$\phi$ [mm]	12	16	20	25	28
Displacement in uncracked concrete						
Temperature range I: 40°C / 24°C	$\delta_{N0}$ [mm/(N/mm <sup>2</sup> )]	0,05	0,06	0,07	0,07	0,08
	$\delta_{N\infty}$ [mm/(N/mm <sup>2</sup> )]	0,12	0,15	0,17	0,18	0,19
Temperature range II: 55°C / 43°C	$\delta_{N0}$ [mm/(N/mm <sup>2</sup> )]	0,06	0,07	0,09	0,09	0,09
	$\delta_{N\infty}$ [mm/(N/mm <sup>2</sup> )]	0,14	0,18	0,20	0,21	0,22
Temperature range III: 75°C / 55°C	$\delta_{N0}$ [mm/(N/mm <sup>2</sup> )]	0,07	0,08	0,09	0,09	0,10
	$\delta_{N\infty}$ [mm/(N/mm <sup>2</sup> )]	0,15	0,19	0,22	0,22	0,23
Displacement in cracked concrete						
Temperature range I: 40°C / 24°C	$\delta_{N0}$ [mm/(N/mm <sup>2</sup> )]	0,06	0,10	0,14	0,15	0,16
	$\delta_{N\infty}$ [mm/(N/mm <sup>2</sup> )]	0,06	0,16	0,16	0,15	0,16
Temperature range II: 55°C / 43°C	$\delta_{N0}$ [mm/(N/mm <sup>2</sup> )]	0,07	0,12	0,17	0,17	0,19
	$\delta_{N\infty}$ [mm/(N/mm <sup>2</sup> )]	0,07	0,19	0,19	0,18	0,19
Temperature range III: 75°C / 55°C	$\delta_{N0}$ [mm/(N/mm <sup>2</sup> )]	0,08	0,13	0,17	0,18	0,20
	$\delta_{N\infty}$ [mm/(N/mm <sup>2</sup> )]	0,08	0,20	0,20	0,19	0,20

**Table C16: Displacements for reinforcing bar (rebar) under tension load in concrete**

Reinforcing bar (rebar)		$\phi$ 8	$\phi$ 10	$\phi$ 12	$\phi$ 14	$\phi$ 16	$\phi$ 20	$\phi$ 25	$\phi$ 28	$\phi$ 30	$\phi$ 32
Displacement in uncracked concrete											
Temperature range I: 40°C / 24°C	$\delta_{N0}$ [mm/(N/mm <sup>2</sup> )]	0,04	0,05	0,05	0,06	0,06	0,07	0,07	0,08	0,08	0,08
	$\delta_{N\infty}$ [mm/(N/mm <sup>2</sup> )]	0,10	0,11	0,12	0,13	0,15	0,17	0,18	0,19	0,19	0,20
Temperature range II: 55°C / 43°C	$\delta_{N0}$ [mm/(N/mm <sup>2</sup> )]	0,05	0,05	0,06	0,07	0,07	0,09	0,09	0,09	0,10	0,10
	$\delta_{N\infty}$ [mm/(N/mm <sup>2</sup> )]	0,12	0,13	0,14	0,16	0,18	0,20	0,21	0,22	0,23	0,24
Temperature range III: 75°C / 55°C	$\delta_{N0}$ [mm/(N/mm <sup>2</sup> )]	0,05	0,06	0,07	0,07	0,08	0,09	0,09	0,10	0,10	0,11
	$\delta_{N\infty}$ [mm/(N/mm <sup>2</sup> )]	0,12	0,13	0,15	0,17	0,19	0,22	0,22	0,23	0,24	0,25
Displacement in cracked concrete											
Temperature range I: 40°C / 24°C	$\delta_{N0}$ [mm/(N/mm <sup>2</sup> )]	0,02	0,03	0,06	0,08	0,10	0,14	0,15	0,16	0,18	0,19
	$\delta_{N\infty}$ [mm/(N/mm <sup>2</sup> )]	0,12	0,19	0,06	0,19	0,16	0,16	0,15	0,16	0,18	0,19
Temperature range II: 55°C / 43°C	$\delta_{N0}$ [mm/(N/mm <sup>2</sup> )]	0,02	0,04	0,07	0,09	0,12	0,17	0,17	0,19	0,21	0,22
	$\delta_{N\infty}$ [mm/(N/mm <sup>2</sup> )]	0,15	0,23	0,07	0,23	0,19	0,19	0,18	0,19	0,21	0,22
Temperature range III: 75°C / 55°C	$\delta_{N0}$ [mm/(N/mm <sup>2</sup> )]	0,02	0,04	0,08	0,10	0,13	0,17	0,18	0,20	0,22	0,24
	$\delta_{N\infty}$ [mm/(N/mm <sup>2</sup> )]	0,16	0,24	0,08	0,24	0,20	0,20	0,19	0,20	0,22	0,24

**Injection system Hilti HIT-RE 500 V4**

**Performances**  
Displacements under tension load in concrete

**Annex C20**

**Table C17: Displacements for threaded rods under shear load**

Threaded rod, HAS-U-..., HIT-V-..., AM...8.8			M8	M10	M12	M16	M20	M24	M27	M30
Threaded rod, HAS-..., HIT-V-..., size [in.]			-	3/8	1/2	5/8	3/4	7/8	1	1 1/4
Displacement	$\delta_{V0}$	[mm/kN]	0,06	0,06	0,05	0,04	0,04	0,03	0,03	0,03
	$\delta_{V\infty}$	[mm/kN]	0,09	0,08	0,08	0,06	0,06	0,05	0,05	0,05

**Table C18: Displacements for internally threaded HIS-(R)N under shear load**

HIS-(R)N			M8	M10	M12	M16	M20
HIS-(R)N, size [in.]			-	3/8	1/2	5/8	3/4
Displacement	$\delta_{V0}$	[mm/kN]	0,06	0,06	0,05	0,04	0,04
	$\delta_{V\infty}$	[mm/kN]	0,09	0,08	0,08	0,06	0,06

**Table C19: Displacements Hilti tension anchor HZA / HZA-R under shear load**

HZA / HZA-R			M12	M16	M20	M24	M27
Displacement	$\delta_{V0}$	[mm/kN]	0,05	0,04	0,04	0,03	0,03
	$\delta_{V\infty}$	[mm/kN]	0,08	0,06	0,06	0,05	0,05

**Table C20: Displacements for reinforcing bar (rebar) under shear load**

Reinforcing bar (rebar)			$\phi$ 8	$\phi$ 10	$\phi$ 12	$\phi$ 14	$\phi$ 16	$\phi$ 20	$\phi$ 25	$\phi$ 28	$\phi$ 30	$\phi$ 32
Displacement	$\delta_{V0}$	[mm/kN]	0,05	0,05	0,05	0,04	0,04	0,04	0,03	0,03	0,03	0,03
	$\delta_{V\infty}$	[mm/kN]	0,08	0,08	0,07	0,06	0,06	0,05	0,05	0,05	0,04	0,04

**Injection system Hilti HIT-RE 500 V4**

**Performances**  
Displacements shear load load in concrete

**Annex C21**

**Table C21: Essential characteristics for threaded rods under tension loads for seismic category C1 in concrete**

Threaded rod, HAS-U-..., HIT-V-..., AM...8.8	M8	M10	M12	M16	M20	M24	M27	M30
<b>Steel failure</b>								
Characteristic resistance $N_{Rk,s,C1}$ [kN]	$A_s \cdot f_{uk}$							
<b>Combined pullout and concrete cone failure</b>								
Characteristic resistance in cracked concrete C20/25 in hammer drilled holes and hammer drilled holes with Hilti hollow drill bit TE-CD or TE-YD and diamond cored holes with roughening with Hilti Roughening tool TE-YRT								
Temperature range I: 40°C / 24°C $\tau_{Rk,C1}$ [N/mm <sup>2</sup> ]	6,8	8,2	10,2	10,4	9,7	9,4	9,0	8,5
Temperature range II: 55°C / 43°C $\tau_{Rk,C1}$ [N/mm <sup>2</sup> ]	6,3	7,3	8,3	8,0	7,7	7,9	7,5	7,0
Temperature range III: 75°C / 55°C $\tau_{Rk,C1}$ [N/mm <sup>2</sup> ]	4,0	3,1	3,2	3,3	3,0	3,0	3,0	3,0
<b>Influence factor <math>\psi</math> on bond resistance <math>\tau_{Rk,C1}</math></b>								
Influence of concrete strength								
Cracked and uncracked concrete $\psi_c$	C30/37		1,0					
	C40/50							
	C50/60							

**Table C22: Essential characteristics for threaded rods under tension loads for seismic category C1 in concrete**

Threaded rod, HAS-..., HIT-V-..., size [in.]	3/8	1/2	5/8	3/4	7/8	1	1 1/4
<b>Steel failure</b>							
Characteristic resistance $N_{Rk,s,C1}$ [kN]	$A_s \cdot f_{uk}$						
<b>Combined pullout and concrete cone failure</b>							
Characteristic resistance in cracked concrete C20/25 in hammer drilled holes and hammer drilled holes with Hilti hollow drill bit TE-CD or TE-YD and diamond cored holes with roughening with Hilti Roughening tool TE-YRT							
Temperature range I: 40°C / 24°C $\tau_{Rk,C1}$ [N/mm <sup>2</sup> ]	7,9	10,0	10,5	10,0	9,0	9,0	8,5
Temperature range II: 55°C / 43°C $\tau_{Rk,C1}$ [N/mm <sup>2</sup> ]	7,0	8,2	8,1	8,4	8,0	7,5	7,0
Temperature range III: 75°C / 55°C $\tau_{Rk,C1}$ [N/mm <sup>2</sup> ]	3,1	3,2	3,3	3,0	3,0	3,0	2,5
<b>Influence factor <math>\psi</math> on bond resistance <math>\tau_{Rk,C1}</math></b>							
Influence of concrete strength							
Cracked and uncracked concrete $\psi_c$	C30/37		1,0				
	C40/50						
	C50/60						

**Injection system Hilti HIT-RE 500 V4**

**Performances**

Essential characteristics under tension for seismic performance category C1 in concrete

**Annex C22**

**Table C23: Essential characteristics for internally threaded sleeve HIS-(R)N under tension load for seismic category C1 in concrete**

HIS-(R)N			M8	M10	M12	M16	M20	
<b>Steel failure</b>								
Characteristic resistance HIS-N	$N_{Rk,s,C1}$	[kN]	25	46	67	125	116	
Characteristic resistance HIS-RN	$N_{Rk,s,C1}$	[kN]	26	41	59	110	166	
<b>Combined pullout and concrete cone failure</b>								
Characteristic resistance in cracked concrete C20/25 in <b>hammer drilled holes</b> and <b>hammer drilled holes with Hilti hollow drill bit TE-CD or TE-YD</b> and <b>diamond cored holes with roughening with Hilti Roughening tool TE-YRT</b>								
Temperature range I: 40°C / 24°C	$\tau_{Rk,C1}$	[N/mm <sup>2</sup> ]	8,3	8,5	8,7	9,0	9,0	
Temperature range II: 55°C / 43°C	$\tau_{Rk,C1}$	[N/mm <sup>2</sup> ]	7,4	7,6	7,8	8,0	8,0	
Temperature range III: 75°C / 55°C	$\tau_{Rk,C1}$	[N/mm <sup>2</sup> ]	2,8	2,9	2,9	3,0	3,0	
<b>Influence factor <math>\psi</math> on bond resistance <math>\tau_{Rk,C1}</math></b>								
Influence of concrete strength								
Cracked and uncracked concrete	$\psi_c$	C30/37	1,0					
		C40/50						
		C50/60						

Injection system Hilti HIT-RE 500 V4

**Performances**

Essential characteristics under tension for seismic performance category C1 in concrete

Annex C23

**Table C24: Essential characteristics for internally threaded sleeve HIS-(R)N under tension load for seismic category C1 in concrete**

HIS-(R)N, size		[in.]	3/8	1/2	5/8	3/4
<b>Steel failure</b>						
Characteristic resistance HIS-N Screw acc. to SAE J429 Grade 5 or ASTM A325 (1/2 in. to 3/4 in.)	$N_{Rk,s,C1}$	[kN]	41	76	121	130
Characteristic resistance HIS-N Screw acc. to ASTM A193 Grade B7	$N_{Rk,s,C1}$	[kN]	43	77	128	130
Characteristic resistance HIS-RN Screw acc. to ASTM A193 Grade B8M (AISI 316)	$N_{Rk,s,C1}$	[kN]	38	110	182	185
Characteristic resistance HIS-RN Screw acc. to ASTM A193 Grade B8T (AISI 321)	$N_{Rk,s,C1}$	[kN]	43	110	182	185
<b>Combined pullout and concrete cone failure</b>						
Characteristic resistance in cracked concrete C20/25 in <b>hammer drilled holes</b> and <b>hammer drilled holes with Hilti hollow drill bit TE-CD or TE-YD</b> and <b>diamond cored holes with roughening with Hilti Roughening tool TE-YRT</b>						
Temperature range I: 40°C / 24°C	$\tau_{Rk,C1}$	[N/mm <sup>2</sup> ]	7,9	8,2	8,5	8,9
Temperature range II: 55°C / 43°C	$\tau_{Rk,C1}$	[N/mm <sup>2</sup> ]	7,0	7,3	7,6	7,9
Temperature range III: 75°C / 55°C	$\tau_{Rk,C1}$	[N/mm <sup>2</sup> ]	2,9	2,9	3,0	3,0
<b>Influence factor <math>\psi</math> on bond resistance <math>\tau_{Rk,C1}</math></b>						
Influence of concrete strength						
Cracked and uncracked concrete	$\psi_c$	C30/37	1,0			
		C40/50				
		C50/60				

**Injection system Hilti HIT-RE 500 V4**

**Performances**

Essential characteristics under tension for seismic performance category C1 in concrete

**Annex C24**

**Table C25: Essential characteristics for Hilti tension anchor HZA / HZA-R under tension load for seismic category C1 in concrete**

HZA / HZA-R			M12	M16	M20	M24	M27	
Rebar diameter	$\phi$	[mm]	12	16	20	25	28	
<b>Steel failure</b>								
Characteristic resistance HZA	$N_{Rk,s,C1}$	[kN]	46	86	135	194	252	
Characteristic resistance HZA-R	$N_{Rk,s,C1}$	[kN]	62	111	173	249	<sup>1)</sup>	
<b>Combined pullout and concrete cone failure</b>								
Characteristic resistance in cracked concrete C20/25 in <b>hammer drilled holes</b> and <b>hammer drilled holes with Hilti hollow drill bit TE-CD or TE-YD</b> and <b>diamond cored holes with roughening with Hilti Roughening tool TE-YRT</b>								
Temperature range I:	40°C / 24°C	$\tau_{Rk,C1}$	[N/mm <sup>2</sup> ]	11	11,4	11,6	10,9	11
Temperature range II:	55°C / 43°C	$\tau_{Rk,C1}$	[N/mm <sup>2</sup> ]	9,2	9,5	9,7	9,4	9,5
Temperature range III:	75°C / 55°C	$\tau_{Rk,C1}$	[N/mm <sup>2</sup> ]	3,7	4,3	4,4	4,5	4,5
<b>Influence factor <math>\psi</math> on bond resistance <math>\tau_{Rk,C1}</math></b>								
Influence of concrete strength								
Cracked and uncracked concrete	$\psi_c$	C30/37	1,0					
		C40/50						
		C50/60						

<sup>1)</sup> No performance assessed.

**Table C26: Essential characteristics for reinforcing bars (rebars) under tension load for seismic category C1 in concrete**

Reinforcing bar (rebar)				$\phi$ 8	$\phi$ 10	$\phi$ 12	$\phi$ 14	$\phi$ 16	$\phi$ 20	$\phi$ 25	$\phi$ 28	$\phi$ 30	$\phi$ 32
<b>Steel failure</b>													
Characteristic resistance Rebar B500B acc. to DIN 488:2009-08 <sup>1)</sup>	$N_{Rk,s,C1}$	[kN]	<sup>2)</sup>	43	62	85	111	173	270	339	388	442	
<b>Combined pullout and concrete cone failure</b>													
Characteristic resistance in cracked concrete C20/25 in <b>hammer drilled holes</b> and <b>hammer drilled holes with Hilti hollow drill bit TE-CD or TE-YD</b> and <b>diamond cored holes with roughening with Hilti Roughening tool TE-YRT</b>													
Temperature range I:	40°C / 24°C	$\tau_{Rk,C1}$	[N/mm <sup>2</sup> ]	<sup>2)</sup>	9,1	11	11	11,4	11,6	10,9	11	11	11
Temperature range II:	55°C / 43°C	$\tau_{Rk,C1}$	[N/mm <sup>2</sup> ]	<sup>2)</sup>	7,7	9,2	9,2	9,5	9,7	9,4	9,5	9,5	9,0
Temperature range III:	75°C / 55°C	$\tau_{Rk,C1}$	[N/mm <sup>2</sup> ]	<sup>2)</sup>	3,6	3,7	4,7	4,3	4,4	4,5	4,5	4,5	4,5
<b>Influence factor <math>\psi</math> on bond resistance <math>\tau_{Rk,C1}</math></b>													
Influence of concrete strength													
Cracked and uncracked concrete	$\psi_c$	C30/37	1,0										
		C40/50											
		C50/60											

<sup>1)</sup> Values need to be calculated acc. EAD 330499-01, Eq. 2.1, if rebars do not fulfil the requirements acc. DIN 488.

<sup>2)</sup> No performance assessed.

**Injection system Hilti HIT-RE 500 V4**

**Performances**

Essential characteristics under tension for seismic performance category C1 in concrete

**Annex C25**

**Table C27: Essential characteristics for threaded rods under shear loads for seismic category C1 in concrete**

Threaded rod, HAS-U-..., HIT-V-..., AM...8.8	M8	M10	M12	M16	M20	M24	M27	M30
<b>Steel failure without lever arm</b>								
Characteristic resistance HAS-U-..., HIT-V-..., AM...8.8	$V_{Rk,s,C1}$	[kN]	$0,5 \cdot A_s \cdot f_{uk}$					
Characteristic resistance Commercial standard threaded rod	$V_{Rk,s,C1}$	[kN]	$0,35 \cdot A_s \cdot f_{uk}$					

**Table C28: Essential characteristics for threaded rods under shear loads for seismic category C1 in concrete**

Threaded rod, HAS-..., HIT-V-..., size	[in.]	3/8	1/2	5/8	3/4	7/8	1	1 1/4
<b>Steel failure without lever arm</b>								
Characteristic resistance HAS-..., HIT-V...	$V_{Rk,s,C1}$	[kN]	$0,5 \cdot A_s \cdot f_{uk}$					
Characteristic resistance Commercial standard threaded rod	$V_{Rk,s,C1}$	[kN]	$0,35 \cdot A_s \cdot f_{uk}$					

**Table C29: Essential characteristics for internally threaded sleeve HIS-(R)N under shear load for seismic category C1 in concrete**

HIS-(R)N	M8	M10	M12	M16	M20		
<b>Steel failure without lever arm</b>							
Characteristic resistance HIS-N with screw 8.8	$V_{Rk,s,C1}$	[kN]	9	16	27	41	39
Characteristic resistance HIS-RN with screw grade 70	$V_{Rk,s,C1}$	[kN]	9	14	21	39	58

**Table C30: Essential characteristics for internally threaded sleeve HIS-(R)N under shear load for seismic category C1 in concrete**

HIS-(R)N, size	[in.]	3/8	1/2	5/8	3/4	
<b>Steel failure without lever arm</b>						
Characteristic resistance HIS-N Screw acc. to SAE J429 Grade 5 or ASTM A325 (1/2 in. to 3/4 in.)	$V_{Rk,s,C1}$	[kN]	14	27	42	45
Characteristic resistance HIS-N Screw acc. to ASTM A193 Grade B7	$V_{Rk,s,C1}$	[kN]	15	28	44	45
Characteristic resistance HIS-RN Screw acc. to ASTM A193 Grade B8M (AISI 316)	$V_{Rk,s,C1}$	[kN]	13	24	39	65
Characteristic resistance HIS-RN Screw acc. to ASTM A193 Grade B8T (AISI 321)	$V_{Rk,s,C1}$	[kN]	15	28	44	65

**Injection system Hilti HIT-RE 500 V4**

**Performances**

Essential characteristics under shear for seismic performance category C1 in concrete

**Annex C26**

**Table C31: Essential characteristics for Hilti tension anchor HZA / HZA-R under shear load for seismic category C1 in concrete**

HZA / HZA-R			M12	M16	M20	M24	M27
<b>Steel failure without lever arm</b>							
Characteristic resistance HZA	$V_{Rk,s,C1}$	[kN]	23	43	67	97	126
Characteristic resistance HZA-R	$V_{Rk,s,C1}$	[kN]	31	55	86	124	<sup>1)</sup>

<sup>1)</sup> No performance assessed.

**Table C32: Essential characteristics for reinforcing bars (rebars) under shear loads for seismic category C1 in concrete**

Reinforcing bar (rebar)		$\phi$ 8	$\phi$ 10	$\phi$ 12	$\phi$ 14	$\phi$ 16	$\phi$ 20	$\phi$ 25	$\phi$ 28	$\phi$ 30	$\phi$ 32	
<b>Steel failure without lever arm</b>												
Characteristic resistance Rebar B500B acc. to DIN 488:2009-08 <sup>1)</sup>	$V_{Rk,s,C1}$	[kN]	<sup>2)</sup>	15	22	29	39	60	95	118	135	155

<sup>1)</sup> Values need to be calculated acc. EAD 330499-01, Eq. 2.1, if rebars do not fulfil the requirements acc. DIN 488.

<sup>2)</sup> No performance assessed.

Injection system Hilti HIT-RE 500 V4

**Performances**

Essential characteristics under shear for seismic performance category C1 in concrete

**Annex C27**

**Table C33: Essential characteristics for threaded rods under tension load for seismic category C2 in concrete**

Threaded rod, HAS-U-..., HIT-V-..., AM...8.8	M8	M10	M12	M16	M20	M24	M27	M30	
<b>Steel failure threaded rods</b>									
Characteristic resistance HAS-U 8.8 (HDG), HIT-V-8.8 (F), AM (HDG) 8.8, Commercial standard threaded rod 8.8 (HDG)	$N_{Rk,s,C2}$	[kN]	1)	$A_s \cdot f_{uk}$					
Characteristic resistance HAS-U HCR, HIT-V-HCR, Commercial standard threaded rod HCR	$N_{Rk,s,C2}$	[kN]	1)	$A_s \cdot f_{uk}$			1)		
<b>Combined pullout and concrete cone failure</b>									
Characteristic resistance in cracked concrete C20/25 in <b>hammer drilled holes</b> and <b>hammer drilled holes with Hilti hollow drill bit TE-CD or TE-YD</b>									
Temperature range I: 40°C / 24°C	$\tau_{Rk,C2}$	[N/mm <sup>2</sup> ]	1)	3,3	6,5	5,8	6,0	5,0	5,2
Temperature range II: 55°C / 43°C	$\tau_{Rk,C2}$	[N/mm <sup>2</sup> ]	1)	2,7	5,3	4,7	4,9	4,1	4,3
Temperature range III: 75°C / 55°C	$\tau_{Rk,C2}$	[N/mm <sup>2</sup> ]	1)	1,1	2,1	1,9	1,9	1,6	1,7
<b>Influence factor <math>\psi</math> on bond resistance <math>\tau_{Rk,C2}</math></b>									
Influence of concrete strength									
Cracked and uncracked concrete	$\psi_c$	C30/37	1,0						
		C40/50							
		C50/60							

1) No performance assessed.

**Injection system Hilti HIT-RE 500 V4**

**Performances**

Essential characteristics for seismic performance category C2 in concrete

**Annex C28**

**Table C34: Essential characteristics for threaded rods under shear loads for seismic category C2 in concrete**

Threaded rod, HAS-U-..., HIT-V-..., AM...8.8	M8	M10	M12	M16	M20	M24	M27	M30
<b>Steel failure without lever arm with Hilti filling set</b>								
Characteristic resistance HAS-U 8.8, HIT-V-8.8, AM 8.8	$V_{Rk,s,C2}$ [kN]	1)	28	46	77	103	1)	
<b>Steel failure without lever arm without Hilti filling set</b>								
Characteristic resistance HAS-U 8.8, HIT-V-8.8, AM 8.8	$V_{Rk,s,C2}$ [kN]	1)	24	40	71	90	121	135
Characteristic resistance HAS-U 8.8 HDG, HIT-VF 8.8, AM HDG 8.8	$V_{Rk,s,C2}$ [kN]	1)	18	30	46	66	1)	
Characteristic resistance HAS-U HCR, HIT-V-HCR	$V_{Rk,s,C2}$ [kN]	1)	24	40	71	1)		
Characteristic resistance Commercial standard threaded rod 8.8	$V_{Rk,s,C2}$ [kN]	1)	17	28	50	63	85	101
Characteristic resistance Commercial standard threaded rod HCR	$V_{Rk,s,C2}$ [kN]	1)	17	28	50	1)		

1) No performance assessed.

**Injection system Hilti HIT-RE 500 V4**

**Performances**

Essential characteristics for seismic performance category C2 in concrete

**Annex C29**

**Table C35: Displacement for threaded rods under tension loads for seismic category C2 in concrete**

Threaded rod, HAS-U-..., HIT-V-..., AM...8.8	M8	M10	M12	M16	M20	M24	M27	M30
Displacement DLS $\delta_{N,C2(DLS)}$ [mm]	1)		0,2	0,5	0,5	0,4	0,4	0,5
Displacement ULS $\delta_{N,C2(ULS)}$ [mm]	1)		0,6	1,2	0,9	0,8	1,0	0,9

1) No performance assessed.

**Table C36: Displacement for threaded rods under shear loads for seismic category C2 in concrete**

Threaded rod, HAS-U-..., HIT-V-..., AM...8.8	M8	M10	M12	M16	M20	M24	M27	M30
<b>Installation with Hilti filling set</b>								
Displacement DLS								
HAS-U 8.8, HIT-V 8.8, AM 8.8 $\delta_{N,C2(DLS)}$ [mm]	1)		1,6	1,2	1,4	1,1	1)	
Displacement ULS								
HAS-U 8.8, HIT-V 8.8, AM 8.8 $\delta_{N,C2(ULS)}$ [mm]	1)		4,5	3,2	3,7	2,6	1)	
<b>Installation without Hilti filling set</b>								
Displacement DLS								
HAS-U 8.8, HIT-V 8.8, AM 8.8 $\delta_{N,C2(DLS)}$ [mm]	1)		1,9	3,2	2,5	3,5	3,0	1,9
HAS-U 8.8 HDG, HIT-V-F 8.8, AM HDG 8.8 $\delta_{N,C2(DLS)}$ [mm]	1)		2,2	2,3	3,8	3,4	1)	
HAS-U HCR, HIT-V-HCR $\delta_{N,C2(DLS)}$ [mm]	1)		1,9	3,2	2,5	1)		
Displacement ULS								
HAS-U 8.8, HIT-V 8.8, AM 8.8 $\delta_{N,C2(ULS)}$ [mm]	1)		4,4	9,2	7,1	10,2	7,2	6,3
HAS-U 8.8 HDG, HIT-V-F 8.8, AM HDG 8.8 $\delta_{N,C2(ULS)}$ [mm]	1)		4,1	4,3	9,1	8,4	1)	
HAS-U HCR, HIT-V-HCR $\delta_{N,C2(ULS)}$ [mm]	1)		4,4	9,2	7,1	1)		

1) No performance assessed.

**Injection system Hilti HIT-RE 500 V4**

**Performances**

Displacements for seismic performance category C2 in concrete

**Annex C30**