

PROVIDE 1/4"X2"X2" 304 S.S. PLATE WASHERS BETWEEN CONC. AND PLATE

1/4 1 5 1/2



1/16 IN. GAP PER DOWN. WN.

PL 1/4"X2" X 0'-2" 2M2

CL

W.P.

PLATE ASSEMBLY 2M1

#3 GALVANIZED CLEVIS W/ 1 1/4" DIA. PIN

1" GUSSET PLATE



VERIFY IN FIELD DIMENSIONAL DIFFERENCE OF WALL AT UPPER GUSSET PLATE VERSUS WALL AT FRAMING BELOW.

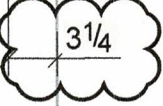

(E) CONC. BEAM

1 1/4" GALVANIZED TURNBUCKLE AS REQUIRED

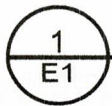

DETAIL

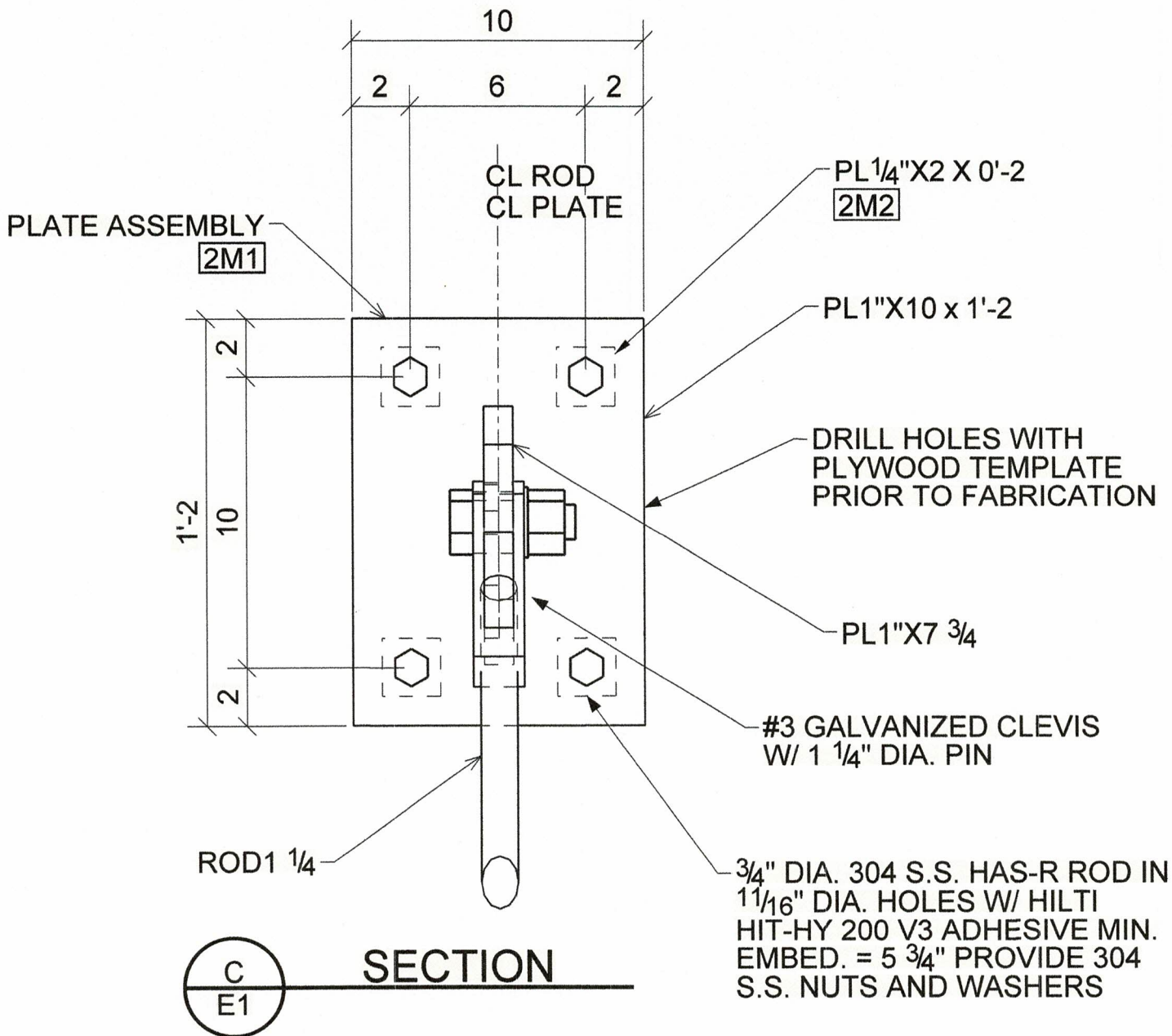

D CLEVIS
AND ROD

(4)

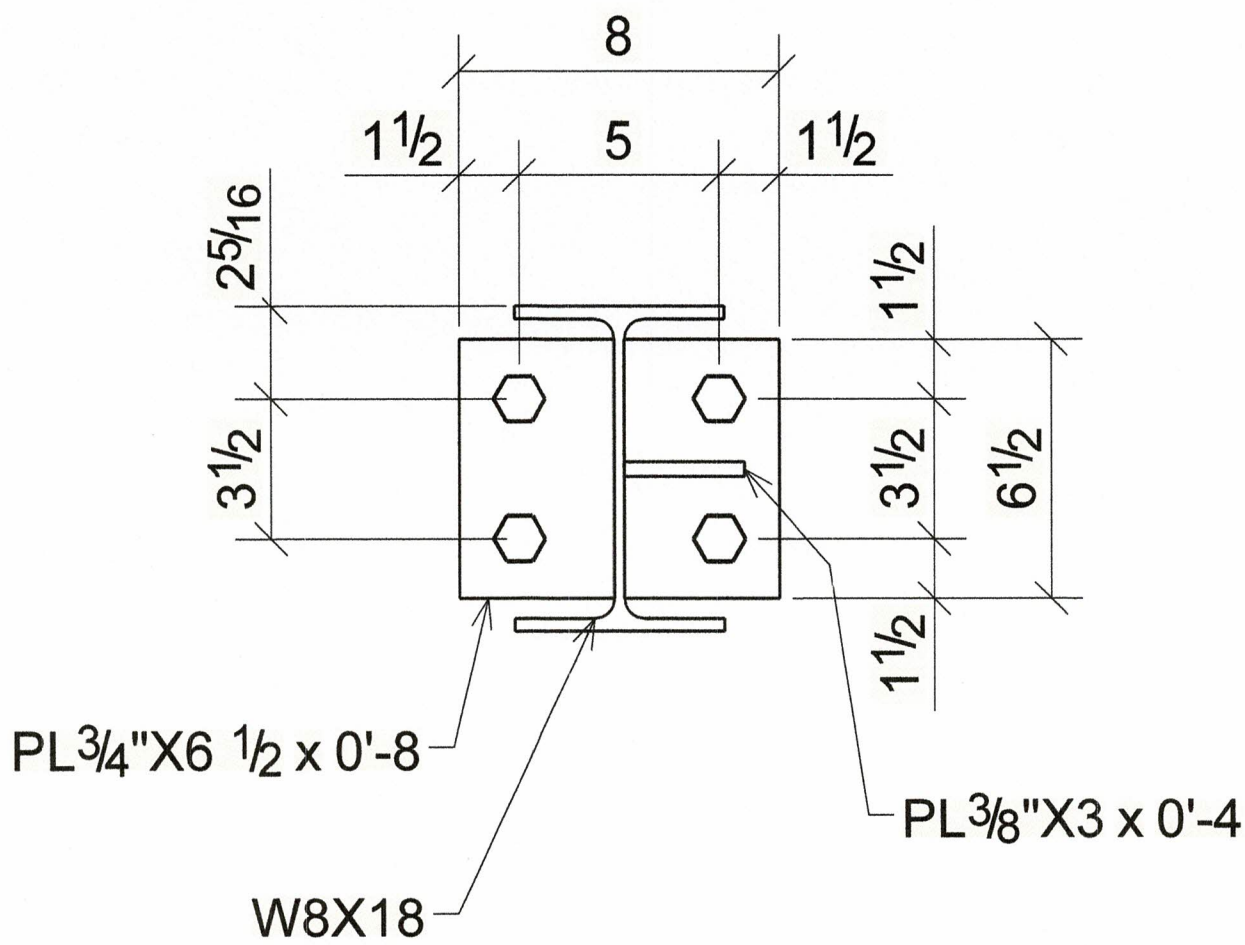

F
E2

SECTION

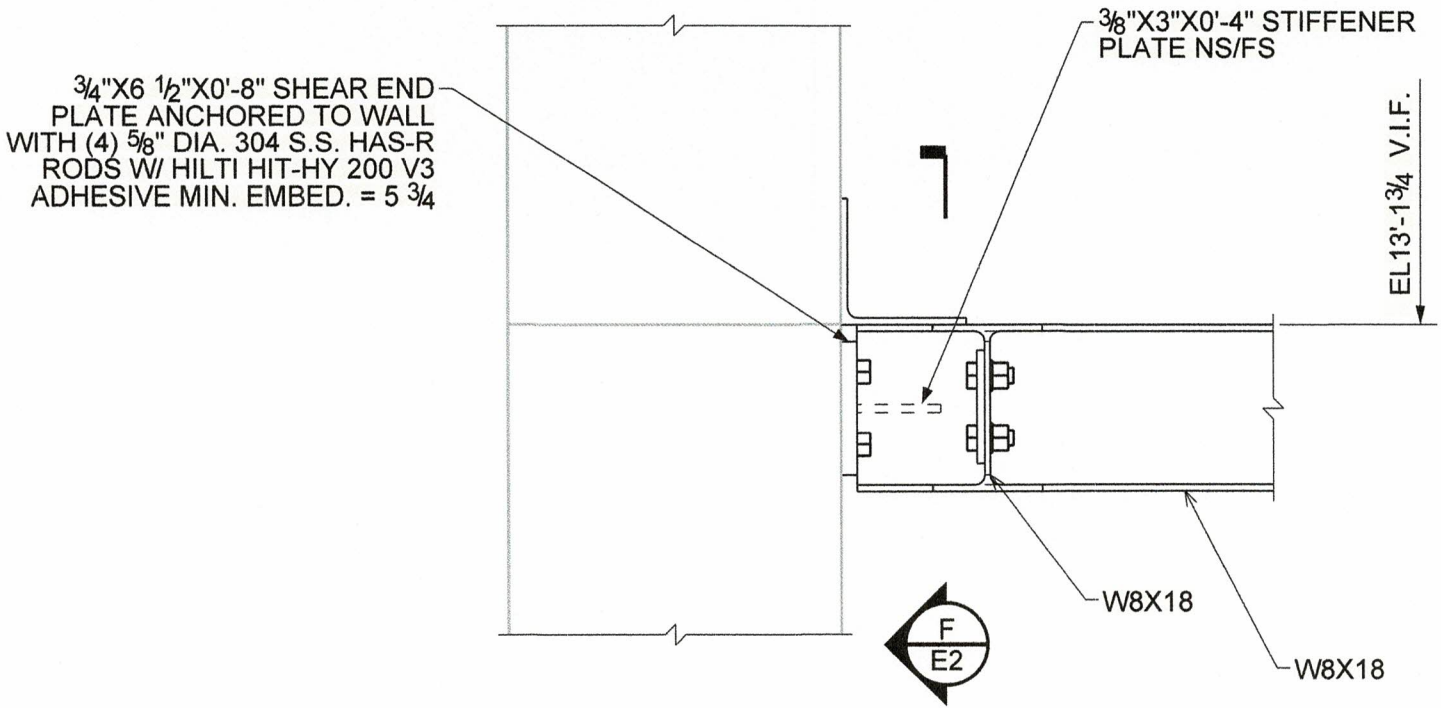

3
E2

DETAIL