

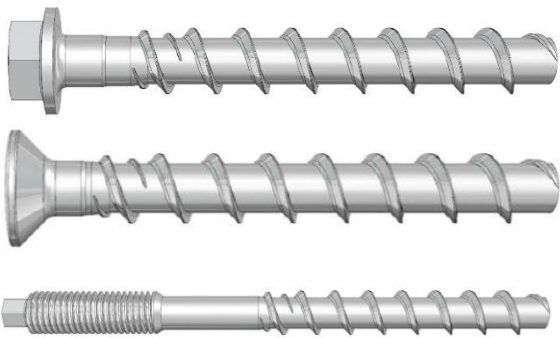

# Hilti HUS4 SCREW ANCHOR

**Technical Datasheet**



**Update: Mar-23**







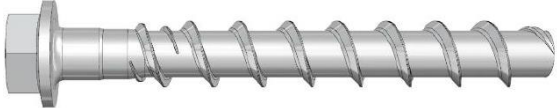



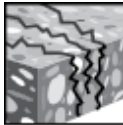

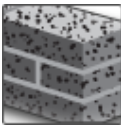
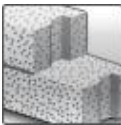
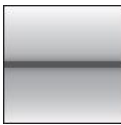
# HUS4 Screw anchor

Ultimate performance screw anchor for single point fastening

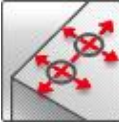
Anchor version		Benefits
	HUS4-H(F) (8-16)*	- High productivity - less drilling and fewer operations than with conventional anchors
	HUS4-C (8-10)	- ETA approval for cracked and non-cracked concrete - ETA approval for Seismic C1 and C2
	HUS4-A(F) (10-14)	- ETA approval for adjustability (unscrew-rescrew) - Smaller edge and spacing distance - aBG (DIBt) approval for reusability in fresh concrete ( $f_{ck, cube} = 10/15/20/25 \text{ Nmm}^2$ ) for temporary applications - Three embedment depths for maximum design flexibility and flexible design for concrete cone capacity - No cleaning required size 8 to 14 - HUS4-HF and HUS4-AF with multilayer coatings for additional corrosion protection - Through fastening with H, A and C head - Pre-fastening with A head

Base material				Load conditions			
							
Concrete (non-cracked)	Concrete (cracked)	Hollow core slabs	Solid brick	Autoclaved aerated concrete	Static / quasi-static	Seismic ETA-C1/C2	Fire resistance

Installation conditions	Other information			
				
Small edge distance and spacing	European Technical Assessment	CE conformity	PROFIS Engineering design software	DIBt Approval Reusability

## Approvals / certificates

Description	Authority	No. / date of issue
European Technical Assessment	DIBt	ETA-20/0867 / 14-04-2022
Fire test report	DIBt	ETA-20/0867 / 14-04-2022
aBG for temporary fastening	DIBt	Z-21.8-2137 / 21-12-2021

\*HUS4-HF not available in size 12

## Static and quasi-static loading data (for a single anchor)

### All data in this section applies to:

- Correct setting (See setting instruction)
- No edge distance and spacing influence
- Steel failure
- Minimum base material thickness
- Concrete C 20/25,  $f_{ck,cube} = 25 \text{ N/mm}^2$

### Anchorage depth

Anchor size		8			10			12			14			16	
Type	HUS4	H, HF, C			H, HF, C, A, AF			H			H, HF, A, AF			H, HF	
		$h_{nom1}$	$h_{nom2}$	$h_{nom3}$	$h_{nom1}$	$h_{nom2}$	$h_{nom3}$	$h_{nom1}$	$h_{nom2}$	$h_{nom3}$	$h_{nom1}$	$h_{nom2}$	$h_{nom3}$	$h_{nom1}$	$h_{nom2}$
Nominal embedment depth	$h_{nom}$ [mm]	40	60	70	55	75	85	60	80	100	65	85	115	85	130

### Characteristic resistance

Anchor size		8			10			12			14			16	
Type	HUS4	H, HF, C			H, HF, C, A, AF			H			H, HF, A, AF			H, HF	
		$h_{nom1}$	$h_{nom2}$	$h_{nom3}$	$h_{nom1}$	$h_{nom2}$	$h_{nom3}$	$h_{nom1}$	$h_{nom2}$	$h_{nom3}$	$h_{nom1}$	$h_{nom2}$	$h_{nom3}$	$h_{nom1}$	$h_{nom2}$
<b>Non-cracked concrete</b>															
Tension	$N_{Rk}$ [kN]	8,3	16,2	20,7	13,0	22,0	27,6	15,3	24,5	35,1	17,0	26,6	43,3	22,0	46,0
Shear	$V_{Rk}$ [kN]	8,3	18,8	21,9	13,6	28,8	32,0	30,6	38,9	44,9	34,1	53,1	62,0	53,5	73,1
<b>Cracked concrete</b>															
Tension	$N_{Rk}$ [kN]	5,5	11,3	14,5	9,5	15,8	19,3	10,0	17,2	24,6	11,9	18,6	30,3	16,0	32,0
Shear	$V_{Rk}$ [kN]	5,8	18,8	21,9	9,5	28,8	32,0	21,4	34,4	44,9	23,8	37,2	60,6	37,4	73,1

### Design resistance

Anchor size		8			10			12			14			16	
Type	HUS4	H, HF, C			H, HF, C, A, AF			H			H, HF, A, AF			H, HF	
		$h_{nom1}$	$h_{nom2}$	$h_{nom3}$	$h_{nom1}$	$h_{nom2}$	$h_{nom3}$	$h_{nom1}$	$h_{nom2}$	$h_{nom3}$	$h_{nom1}$	$h_{nom2}$	$h_{nom3}$	$h_{nom1}$	$h_{nom2}$
<b>Non-cracked concrete</b>															
Tension	$N_{Rd}$ [kN]	5,6	10,8	13,8	7,2	14,7	18,4	10,2	16,4	23,4	11,4	17,7	28,8	14,7	30,7
Shear	$V_{Rd}$ [kN]	5,6	15,0	17,5	9,1	23,0	25,6	20,4	31,1	35,9	22,7	35,4	49,6	35,6	58,5
<b>Cracked concrete</b>															
Tension	$N_{Rd}$ [kN]	3,7	7,5	9,6	5,3	10,5	12,9	6,7	11,5	16,4	7,9	12,4	20,2	10,7	21,3
Shear	$V_{Rd}$ [kN]	3,9	15,0	17,5	6,4	21,1	25,6	14,3	22,9	32,8	15,9	24,8	40,4	25,0	49,3

### Recommended loads

Anchor size		8			10			12			14			16	
Type	HUS4	H, HF, C			H, HF, C, A, AF			H			H, HF, A, AF			H, HF	
		$h_{nom1}$	$h_{nom2}$	$h_{nom3}$	$h_{nom1}$	$h_{nom2}$	$h_{nom3}$	$h_{nom1}$	$h_{nom2}$	$h_{nom3}$	$h_{nom1}$	$h_{nom2}$	$h_{nom3}$	$h_{nom1}$	$h_{nom2}$
<b>Non-cracked concrete</b>															
Tension	$N_{Rec}$ [kN]	4,0	7,7	9,8	5,2	10,5	13,1	7,3	11,7	16,7	8,1	12,6	20,6	10,5	21,9
Shear	$V_{Rec}$ [kN]	4,0	10,7	12,5	6,5	16,5	18,3	14,6	22,2	25,7	16,2	25,3	35,4	25,5	41,8
<b>Cracked concrete</b>															
Tension	$N_{Rec}$ [kN]	2,6	5,4	6,9	3,8	7,5	9,2	4,8	8,2	11,7	5,7	8,9	14,4	7,6	15,2
Shear	$V_{Rec}$ [kN]	2,8	10,7	12,5	4,5	15,1	18,3	10,2	16,4	23,4	11,4	17,7	28,8	17,8	35,2

With overall partial safety factor for action  $\gamma = 1,4$ . The partial safety factors for action depend on the type of loading and shall be taken from national regulations.



### Seismic loading data (for single anchor)

**All data in this section applies to:**

- Correct setting (See setting instruction)
- No edge distance and spacing influence
- Steel failure
- Minimum base material thickness
- Concrete C 20/25,  $f_{ck,cube} = 25 \text{ N/mm}^2$
- $\alpha_{gap} = 1,0$  (using Hilti seismic filling set) or  $\alpha_{gap} = 0,5$  (without using Hilti seismic filling set) accordingly

Anchor size		8	10	12	14
Nominal embedment depth	$h_{nom}$ [mm]	$h_{nom3}$	$h_{nom3}$	$h_{nom3}$	$h_{nom3}$
		70	85	100	115

### Characteristic resistance in case of seismic performance category C2

Anchor size		8	10	12	14
<b>with Hilti filling set (HUS4-H and HUS4-A)</b>					
Type	HUS4	H, HF	H, HF, A, AF	H	H, HF, A, AF
Tension	$N_{Rk,seis}$ [kN]	2,7	5,4	11,4	17,7
Shear	$V_{Rk,seis}$	13,9	21,5	27,2	46,5
<b>without Hilti filling set</b>					
Type	HUS4	H, HF, C	H, HF, C, A, AF	H	H, HF, A, AF
Tension	$N_{Rk,seis}$ [kN]	2,7	5,4	11,4	17,7
Shear	$V_{Rk,seis}$	4,7	6,9	11,3	17,2

### Design resistance in case of seismic performance category C2

Anchor size		8	10	12	14
<b>with Hilti filling set (HUS4-H and HUS4-A)</b>					
Type	HUS4	H, HF	H, HF, A, AF	H	H, HF, A, AF
Tension	$N_{Rd,seis}$ [kN]	1,8	3,6	7,6	11,8
Shear	$V_{Rd,seis}$	11,1	17,2	21,8	34,3
<b>without Hilti filling set</b>					
Type	HUS4	H, HF, C	H, HF, C, A, AF	H	H, HF, A, AF
Tension	$N_{Rd,seis}$ [kN]	1,8	3,6	7,6	11,8
Shear	$V_{Rd,seis}$	3,8	5,5	9,0	13,8

### Anchorage depth

Anchor size		8		10		12		14		16	
Type	HUS4	H, HF, C		H, HF, C, A, AF		H		H, HF, A, AF		H, HF	
		$h_{nom2}$	$h_{nom3}$	$h_{nom2}$	$h_{nom3}$	$h_{nom2}$	$h_{nom3}$	$h_{nom2}$	$h_{nom3}$	$h_{nom1}$	$h_{nom2}$
Nominal embedment depth	$h_{nom}$ [mm]	60	70	75	85	80	100	85	115	85	130

### Characteristic resistance in case of seismic performance category C1

Anchor size		8		10		12		14		16	
Type	HUS4	H, HF, C		H, HF, C, A, AF		H		H, HF, A, AF		H, HF	
		$h_{nom2}$	$h_{nom3}$	$h_{nom2}$	$h_{nom3}$	$h_{nom2}$	$h_{nom3}$	$h_{nom2}$	$h_{nom3}$	$h_{nom2}$	$h_{nom3}$
<b>with Hilti filling set (HUS4-H and HUS4-A)</b>											
Tension	$N_{Rk,seis}$ [kN]	9,6	12,3	13,4	16,4	14,6	20,9	15,8	25,7	7,5	19,0
Shear	$V_{Rk,seis}$ [kN]	18,8	18,8	26,7	26,7	29,2	38,9	22,5	34,5	31,8	25,3
<b>without Hilti filling set</b>											
Tension	$N_{Rk,seis}$ [kN]	9,6	12,3	13,4	16,4	14,6	20,9	15,8	25,7	7,5	19,0
Shear	$V_{Rk,seis}$ [kN]	9,4	9,4	13,4	13,4	14,6	19,5	11,3	17,3	15,9	12,7

### Design resistance in case of seismic performance category C1

Anchor size		8		10		12		14		16	
Type	HUS4	H, HF, C		H, HF, C, A, AF		H		H, HF, A, AF		H, HF	
		$h_{nom2}$	$h_{nom3}$	$h_{nom2}$	$h_{nom3}$	$h_{nom2}$	$h_{nom3}$	$h_{nom2}$	$h_{nom3}$	$h_{nom2}$	$h_{nom3}$
<b>with Hilti filling set (HUS4-H and HUS4-A)</b>											
Tension	$N_{Rd,seis}$ [kN]	6,4	8,2	9,0	10,9	9,7	13,9	10,5	17,2	5,0	12,7
Shear	$V_{Rd,seis}$ [kN]	12,8	15,0	17,9	21,4	19,5	27,9	18,0	27,6	21,2	20,2
<b>without Hilti filling set</b>											
Tension	$N_{Rd,seis}$ [kN]	6,4	8,2	9,0	10,9	9,7	13,9	10,5	17,2	5,0	12,7
Shear	$V_{Rd,seis}$ [kN]	6,4	7,5	9,0	10,7	9,7	13,9	9,0	13,8	10,6	10,1



## Fire resistance

### All data in this section applies to:

- Correct setting (see setting instruction)
- No edge distance and spacing influence
- Steel failure
- Minimum base material thickness
- Partial safety factor for resistance under fire exposure  $\gamma_{M,fi}=1,0$  (in absence of other national regulations)
- For more fire resistance data please see ETA-20/0867.

### Anchorage depth

Anchor size		8						10								
Type	HUS4	H, HF			C			H, HF			C			A		
Nominal embedment depth	$h_{nom}$ [mm]	$h_{nom1}$	$h_{nom2}$	$h_{nom3}$	$h_{nom1}$	$h_{nom2}$	$h_{nom3}$	$h_{nom1}$	$h_{nom2}$	$h_{nom3}$	$h_{nom1}$	$h_{nom2}$	$h_{nom3}$	$h_{nom1}$	$h_{nom2}$	$h_{nom3}$
				40	60	70	40	60	70	55	75	85	55	75	85	55

### Characteristic resistance

Anchor size		8						10								
Type	HUS4	H, HF			C			H, HF			C			A		
<b>Fire exposure R30</b>																
Tension	$N_{RK,fi}$ [kN]	0,8	2,6	2,6	0,5	0,5	0,5	2,0	3,9	4,2	1,0	1,0	1,0	2,0	3,9	4,2
Shear	$V_{RK,fi}$ [kN]	0,9	2,6	2,6	0,5	0,5	0,5	2,0	3,9	4,2	1,0	1,0	1,0	2,0	4,2	4,2
<b>Fire exposure R120</b>																
Tension	$N_{RK,fi}$ [kN]	0,7	0,9	0,9	0,2	0,2	0,2	1,5	1,7	1,7	0,6	0,6	0,6	1,6	2,1	2,1
Shear	$V_{RK,fi}$ [kN]	0,7	0,9	0,9	0,2	0,2	0,2	1,5	1,7	1,7	0,6	0,6	0,6	1,6	2,1	2,1

### Design resistance

Anchor size		8						10								
Type	HUS4	H, HF			C			H, HF			C			A		
<b>Fire exposure R30</b>																
Tension	$N_{Rd,fi}$ [kN]	0,8	2,6	2,6	0,5	0,5	0,5	2,0	3,9	4,2	1,0	1,0	1,0	2,0	3,9	4,2
Shear	$V_{Rd,fi}$ [kN]	0,9	2,6	2,6	0,5	0,5	0,5	2,0	3,9	4,2	1,0	1,0	1,0	2,0	4,2	4,2
<b>Fire exposure R120</b>																
Tension	$N_{Rd,fi}$ [kN]	0,7	0,9	0,9	0,2	0,2	0,2	1,5	1,7	1,7	0,6	0,6	0,6	1,6	2,1	2,1
Shear	$V_{Rd,fi}$ [kN]	0,7	0,9	0,9	0,2	0,2	0,2	1,5	1,7	1,7	0,6	0,6	0,6	1,6	2,1	2,1

### Anchorage depth

Anchor size	12			14						16	
Type	H, HF			H, HF			A			H, HF	
Nominal embedment depth $h_{nom}$ [mm]	$h_{nom1}$	$h_{nom2}$	$h_{nom3}$	$h_{nom1}$	$h_{nom2}$	$h_{nom3}$	$h_{nom1}$	$h_{nom2}$	$h_{nom3}$	$h_{nom1}$	$h_{nom2}$
	40	60	70	40	60	70	55	75	85	55	75

### Characteristic resistance

Anchor size	12			14						16		
Type	H, HF			H, HF			A			H, HF		
<b>Fire exposure R30</b>												
Tension	$N_{Rk,fi}$ [kN]	2,4	4,2	6,1	2,9	4,5	7,5	2,9	4,5	7,5	4,6	8,7
Shear	$V_{Rk,fi}$ [kN]	4,9	7,6	7,6	5,9	10,4	10,5	5,9	8,4	8,4	10,6	10,7
<b>Fire exposure R120</b>												
Tension	$N_{Rk,fi}$ [kN]	1,9	3,0	3,1	2,3	3,6	4,4	2,3	3,6	4,3	3,7	4,5
Shear	$V_{Rk,fi}$ [kN]	2,8	3,0	3,1	3,9	4,2	4,4	4,3	4,3	4,3	4,3	4,5

### Design resistance

Anchor size	12			14						16		
Type	H, HF			H, HF			A			H, HF		
<b>Fire exposure R30</b>												
Tension	$N_{Rd,fi}$ [kN]	2,4	4,2	6,1	2,9	4,5	7,5	2,9	4,5	7,5	4,6	8,7
Shear	$V_{Rd,fi}$ [kN]	4,9	7,6	7,6	5,9	10,4	10,5	5,9	8,4	8,4	10,6	10,7
<b>Fire exposure R120</b>												
Tension	$N_{Rd,fi}$ [kN]	1,9	3,0	3,1	2,3	3,6	4,4	2,3	3,6	4,3	3,7	4,5
Shear	$V_{Rd,fi}$ [kN]	2,8	3,0	3,1	3,9	4,2	4,4	4,3	4,3	4,3	4,3	4,5

## Materials

### Mechanical properties



Anchor size		8	10	12	14	16
Nominal tensile strength	$f_{uk}$ [N/mm <sup>2</sup> ]	758	799	767	728	622
Yield strength	$f_{yk}$ [N/mm <sup>2</sup> ]	606	639	613	582	494
Stressed cross-section	$A_s$ [mm <sup>2</sup> ]	47,5	68,9	103	139	173
Moment of resistance	$W$ [mm <sup>3</sup> ]	35	67	130	213	321
Characteristic bending resistance	$M^0_{Rk,s}$ [Nm]	32	64	120	186	240

### Material quality

Type	Material
HUS4 - H, A, C	Carbon steel, galvanized
HUS4 - HF, AF	Carbon steel, multi-layer coating <sup>a)</sup>

a) Multi-layer coating provides a higher corrosion resistance compared to regular hot dip galvanized (HDG) systems with a 40µm coating thickness.

### Head configuration

Type	Part	
HUS4-H HUS4-HF	Hexagonal head	
HUS4-C	Countersunk head	
HUS4-A	External thread	 Hilti HUS4-A, size 10 with external thread M12 and size 14 with external thread M16

### Fastener dimensions and marking HUS4-H(F)

Anchor size		8	10	12	14	16
Type	HUS4	H, HF	H, HF	H	H, HF	H, HF
Outer diameter of screw thread	$d_t$ [mm]	10,50	12,70	14,70	16,70	18,80
Diameter of integrated washer	$d_i$ [mm]	17,50	20,50	23,60	29,00	32,60
Length of the screw (min/max)	$L$ [mm]	45/150	60/305	70/150	75/150	100/205

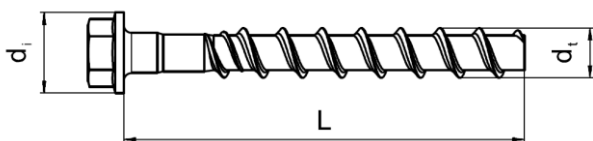

**HUS4:** Hilti Universal Screw 4<sup>th</sup> generation  
**H:** Hexagonal head  
**10:** Screw diameter  
**100:** total length of the screw

### Fastener dimensions and marking HUS4-C

Anchor size		8	10
Type		C	C
Outer diameter of the screw thread	$d_t$ [mm]	10,50	12,70
Countersunk head diameter	$d_h$ [mm]	18,00	21,00
Length of the screw (min/max)	L [mm]	55/85	70/120

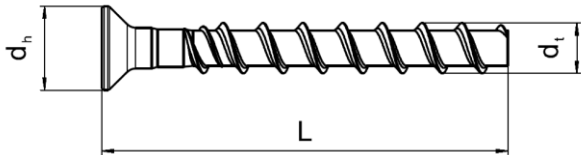

**HUS4:** Hilti Universal Screw 4<sup>th</sup> generation  
**C:** Countersunk head  
**10:** Screw diameter  
**100:** total length of the screw

### Fastener dimensions and marking HUS4-A(F)

Anchor size		10	14
Type		A, AF	A, AF
Outer diameter of the screw thread	$d_t$ [mm]	12,70	16,70
Diameter of the metric thread	$d_M$ [mm]	M12	M16
Length of the screw (min/max)	L [mm]	120/165	155/205

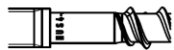
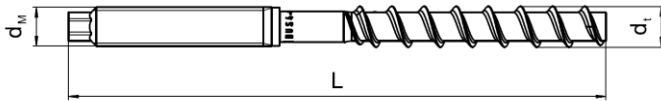

E.g. HUS4-A 10x165



**HUS4:** Hilti Universal Screw 4<sup>th</sup> generation  
**A:** Threaded head  
**10:** Screw diameter  
**100:** total length of the screw  
**8:** carbon steel 8.8  
**K:** length of the screw (more info in ETA)



## Setting information

### Setting details size 8-12

Anchor size		8			10			12		
Type	HUS4	H, HF, C			H, HF, C, A, AF			H		
Nominal embedment depth	[mm]	$h_{nom1}$	$h_{nom2}$	$h_{nom3}$	$h_{nom1}$	$h_{nom2}$	$h_{nom3}$	$h_{nom1}$	$h_{nom2}$	$h_{nom3}$
		40	60	70	55	75	85	60	80	100
Nominal diameter of drill bit	$d_0$ [mm]	8			10			12		
Clearance hole diameter	$d_f \leq$ [mm]	12			14			16		
Wrench size HEX head	SW1 [mm]	13			15			17		
Wrench size Threaded head	SW1 [mm]	-			8			-		
Wrench size for nut on Threaded head	SW2 [mm]	-			19			-		
Torx size "C" head	TX -	45			50			-		
Countersunk head diameter	$d_h$ [mm]	18			21					
Depth of drill hole for cleaned hole; or uncleaned hole overhead	$h_1 \geq$ [mm]	50	70	80	65	85	95	70	90	110
Depth of drill hole for uncleaned hole hammer drilling in wall and floor position	$h_1 \geq$ [mm]	66	86	96	85	105	115	94	114	134

### Setting details size 14-16

Anchor size		14			16	
Type	HUS4	H, HF, A, AF			H, HF	
Nominal embedment depth [mm]		$h_{nom1}$	$h_{nom2}$	$h_{nom3}$	$h_{nom1}$	$h_{nom2}$
		65	85	115	85	130
Nominal diameter of drill bit	$d_0$ [mm]	14			16	
Clearance hole diameter	$d_f \leq$ [mm]	18			20	
Wrench size Hex head	SW1 [mm]	21			24	
Wrench size Threaded head	SW1 [mm]	12			-	
Wrench size for nut on Threaded head	SW2 [mm]	24			-	
Depth of drill hole for cleaned hole; or uncleaned hole overhead	$h_1 \geq$ [mm]	75	95	125	95	140
Depth of drill hole for uncleaned hole hammer drilling in wall and floor position	$h_1 \geq$ [mm]	103	123	153	-	-

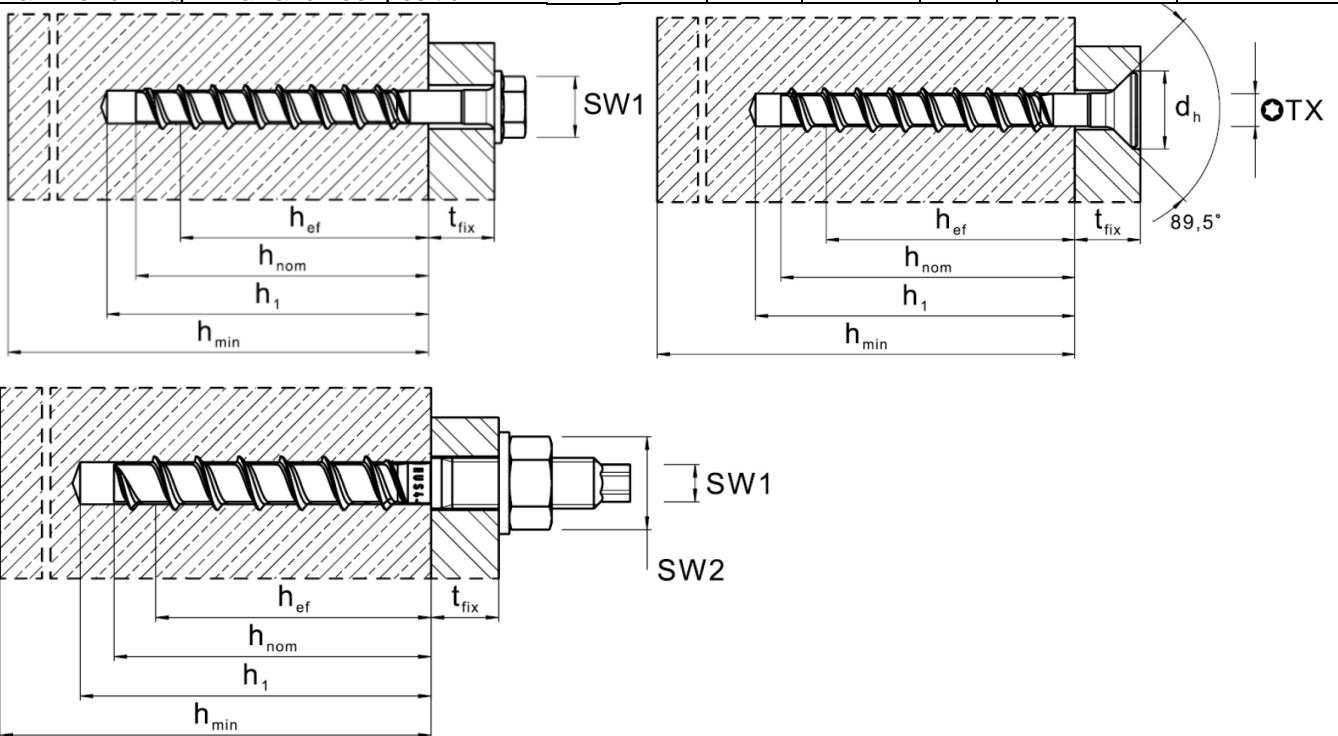



**Installation equipment table:**

Anchor size	8	10	12	14	16
Type	HUS4- H,C,HF	H,HF, C, A, AF	H	H,HF, A, AF	H,HF
Rotary hammer	TE4 – TE30				
Drill bit for concrete, solid clay brick and solid sand-lime brick	TE-CX 8	TE-CX 10	TE-CX 12	TE-CX 14	TE-CX 16
Socket wrench insert for hex screw (SW1)	SI-S ½" 13S	SI-S ½" 15S	S ½" 17S	SI-S ½" 21S	S ½" 24S
Socket wrench insert for threaded head screw	-	SI-S ½" 8S	-	SI-S ½" 12S	-
Socket wrench insert for nuts for threaded head screw (SW2)	-	SI-S ½" 19S	-	SI-S ½" 24S	-
Torx bit for countersunk screw	S-SY TX45	S-SY TX50	-	-	-
Check gauge for reusability <sup>1)</sup>	HRG 8	HRG 10	HRG 12	HRG 14	HRG 16
Setting tool for cracked and un-cracked concrete	SIW 6AT-A22 1/2" SIW 4AT-22 1/2" SIW 6-22 1/2" gear 1	SIW 22T-A 1/2" SIW 22T-A 3/4" SIW 6AT-A22 1/2" SIW 4AT-22 1/2" SIW 6-22 1/2" SIW 8-22 1/2" gear 1 SIW 9-A22 3/4"	SIW 22T-A 1/2" SIW 22T-A 3/4" SIW 6-22 1/2" SIW 8-22 1/2" SIW 9-A22 3/4"		
Setting tool for solid brick and aerated concrete	SIW 6AT-A22 1/2", SIW 4AT-22 1/2"		-		
Setting tool for hollow core slab	SIW 6AT-A22 1/2" SIW 4AT-22 1/2"	SIW 6AT-A22 1/2" SIW 4AT-22 1/2" SIW 22T-A 1/2" SIW 22T-A 3/4" SIW 6AT-A22 1/2"			

1) For HUS4-A and HUS4-H

### Setting parameters

Anchor size		8			10			12			14			16		
Type	HUS4															
Nominal embedment depth	$h_{nom}$ [mm]	40	60	70	55	75	85	60	80	100	65	85	115	85	130	
Minimum base material thickness	$h_{min}$ [mm]	80	100	120	100	130	140	110	130	150	120	160	200	130	195	
Minimum spacing	$s_{min}$ [mm]	35			40			50			60			90		
Minimum edge distance	$c_{min}$ [mm]	35			40			50			60			65		
Critical spacing for splitting failure	$s_{cr,sp}$ [mm]	3 $h_{ef}$			3.3 $h_{ef}$			3.3 $h_{ef}$			3.3 $h_{ef}$					
Critical edge distance for splitting	$c_{cr,sp}$ [mm]	1.5 $h_{ef}$			1.65 $h_{ef}$			1.65 $h_{ef}$			1.65 $h_{ef}$					
Critical spacing for concrete cone failure	$s_{cr,N}$ [mm]	3 $h_{ef}$														
Critical edge distance for concrete cone failure	$c_{cr,N}$ [mm]	1,5 $h_{ef}$														

For spacing (edge distance) smaller than critical spacing (critical edge distance ) the design loads have to be reduced (see system design resistance ).

Critical spacing and critical edge distance for splitting failure apply only for non-cracked concrete. For cracked concrete only the critical spacing and critical edge distance for concrete cone failure are decisive.

### Setting instructions

\*For detailed information on installation see instruction for use given with the package of the product

#### Setting instruction with adjustment

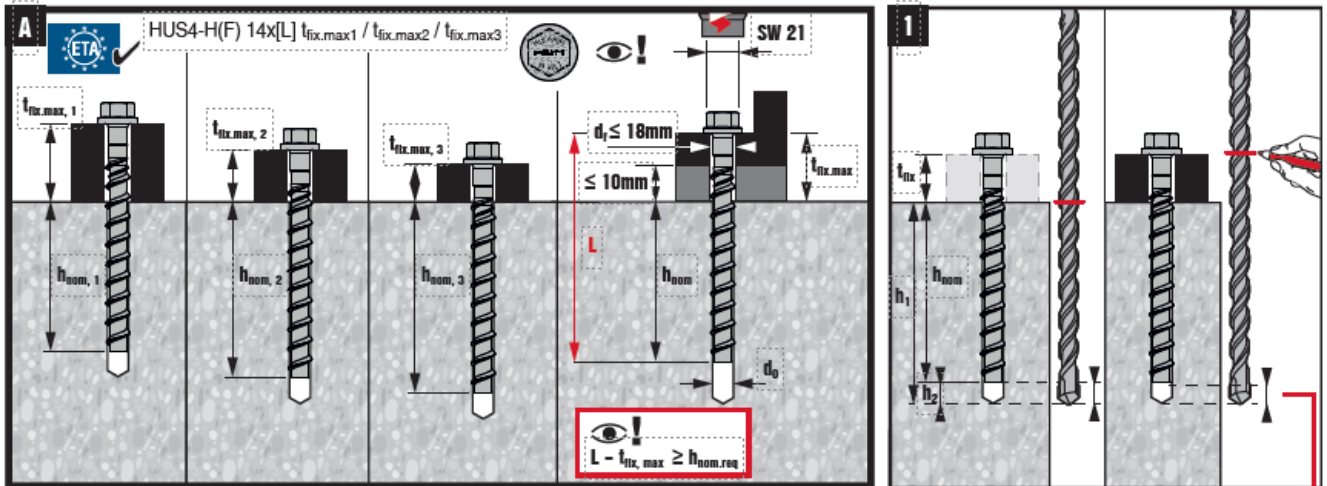

	$d_0$ [mm]	$h_{nom}$		
	$\varnothing 14$	$h_{nom1}$	$\geq 65\text{mm}$	
	$\varnothing 14$	$h_{nom2}$	$\geq 85\text{mm}$	
	$\varnothing 14$	$h_{nom3}$	$\geq 115\text{mm}$	

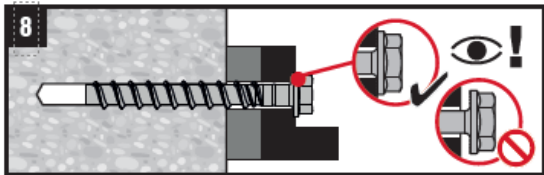
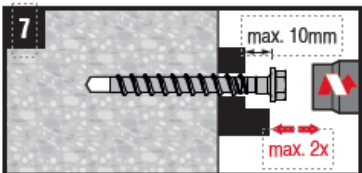
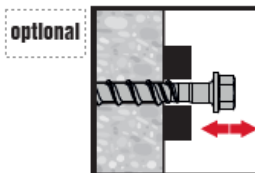
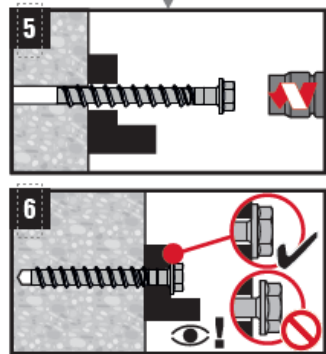
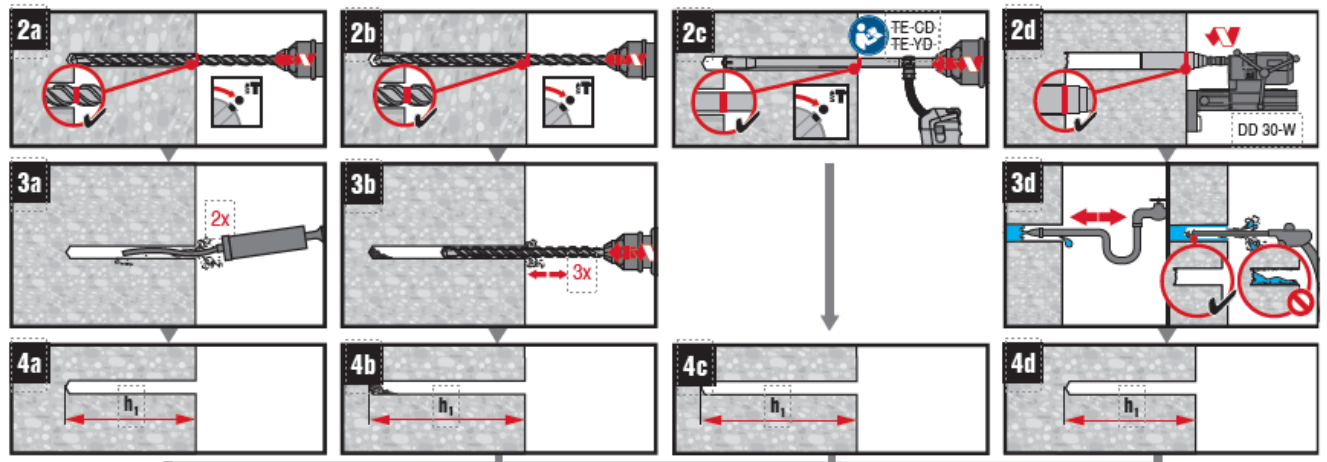
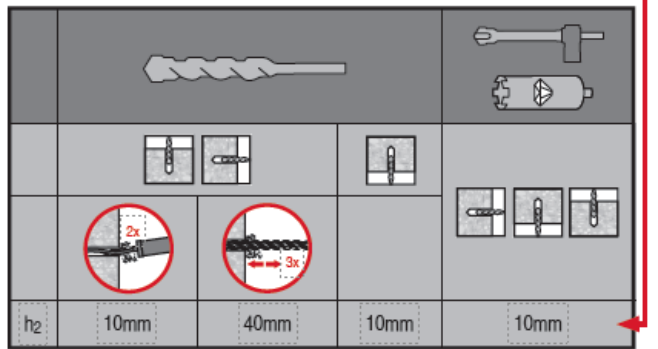

	HUS4-H(F) 14
SIW 22-A 1/2" (01)	
SIW 6AT-A22 1/2" (01)	
SIW 22T-A 1/2" (01)	
SIW 22T-A 3/4" (01)	
SIW 9-A22 3/4" (01)	

**Basic loading data for temporary application in standard and fresh concrete <28 days old,  $f_{ck,cube} \geq 10 \text{ N/mm}^2$**

**All data in this section applies to the following conditions:**

- Strength class,  $f_{ck,cube} \geq 10 \text{ N/mm}^2$
- Only temporary use
- Screw is reusable, before each usage it must be checked according to Hilti instruction for use with the suited tube Hilti HRG
- Design resistance is valid for single anchor only
- Design resistance is valid for all load directions and valid for both cracked and non-cracked concrete
- Minimum base material thickness
- No edge distance and spacing influence
- Valid for HUS4-H and HUS4-A
- All data in this section are according to DIBt approval Z-21.8-2137 issue 2021-12-21

Anchor size		HUS4-H (A)	8		10			12			14			16		
			$h_{nom2}$	$h_{nom3}$	$h_{nom1}$	$h_{nom2}$	$h_{nom3}$	$h_{nom1}$	$h_{nom2}$	$h_{nom3}$	$h_{nom1}$	$h_{nom2}$	$h_{nom3}$	$h_{nom1}$	$h_{nom2}$	
Nominal embedment depth	$h_{nom}$	[mm]	75	85	55	75	85	60	80	100	65	85	115	85	115	
Tension	$\frac{f_{ck,cube} \geq 10 \text{ N/mm}^2}{f_{ck,cube} \geq 15 \text{ N/mm}^2}$	$N_{rd}$	[kN]	3,3	4,7	3,3	5,3	6,3	2,6	5,4	7,8	4,4	7,0	12,3	5,5	12,6
			[kN]	4,0	5,7	4,0	6,4	7,8	3,5	7,3	10,6	5,4	8,5	15,0	7,5	17,0
Shear	$\frac{f_{ck,cube} \geq 20 \text{ N/mm}^2}{f_{ck,cube} \geq 25 \text{ N/mm}^2}$	$V_{rd}$	[kN]	4,6	6,6	4,7	7,4	9,0	4,0	8,4	12,2	6,2	9,9	17,3	8,7	19,7
			[kN]	5,1	7,4	5,3	8,3	10,1	4,5	9,4	13,6	6,9	11,1	19,3	9,7	22,0

**Setting details**

Anchor size		HUS4-H (A)	8		10			12			14			16	
			$h_{nom2}$	$h_{nom3}$	$h_{nom1}$	$h_{nom2}$	$h_{nom3}$	$h_{nom1}$	$h_{nom2}$	$h_{nom3}$	$h_{nom1}$	$h_{nom2}$	$h_{nom3}$	$h_{nom1}$	$h_{nom2}$
Nominal embedment depth	$h_{nom}$	[mm]	60	70	55	75	85	60	80	100	65	85	115	85	130
Drilling depth	$h_1 \geq$	[mm]	70	80	65	85	95	70	90	110	75	95	125	95	140
<b>Option 1</b>															
Minimum edge distance	$c_1 \geq$	[mm]	80	100	75	100	115	65	105	135	85	115	180	105	180
Minimum base material thickness	$h_{min} \geq$	[mm]	120	150	115	150	175	110	160	205	130	175	255	160	220
<b>Option 2</b>															
Minimum edge distance	$c_1 \geq$	[mm]	85	110	85	120	135	65	120	160	100	135	300	115	215
Minimum base material thickness	$h_{min} \geq$	[mm]	100	120	100	130	140	110	130	150	120	160	200	130	195
Minimum edge distance	$c_2 \geq$	[mm]	1.5 x $c_1$												
Minimum spacing	$s_{min} \geq$	[mm]	3.0 x $c_1$												
Check gauge			HRG 8		HRG 10			HRG 12			HRG 14			HRG 16	
Diameter of clearance hole for H head	$d_f \leq$	[mm]	14		16			20			22			24	
Diameter of clearance hole for A head	$d_f \leq$	[mm]	-		14			-			18			-	
Socket size H head	SW		13		15			17			21			24	
Socket size A head	SW1 (SW2)		-		8 (17)			-			12 (24)			-	

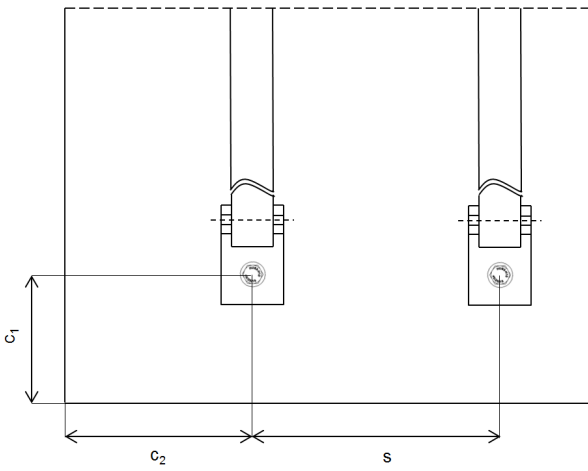
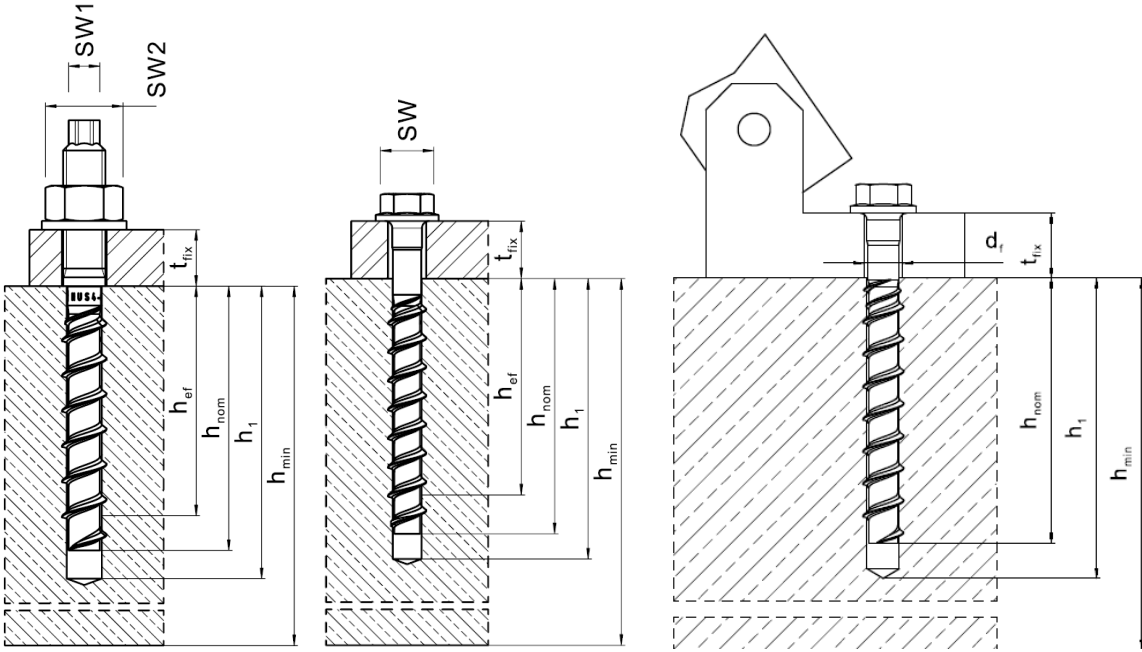

### Setting instructions

\*For detailed information on installation see instruction for use given with the package of the product example for size 10 screw

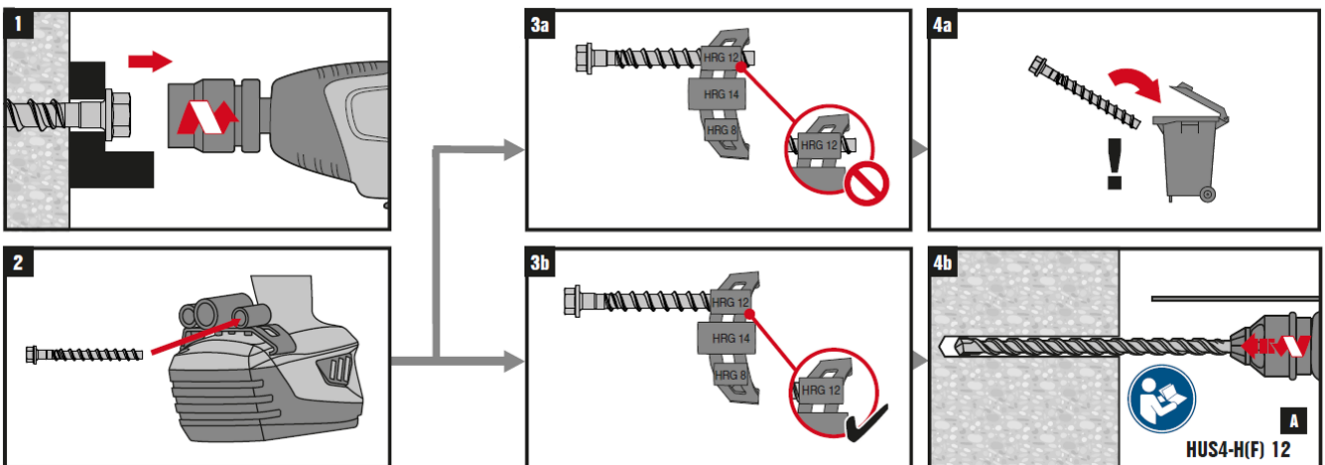









## Basic loading data (for a single anchor) in solid masonry units

### All data in this section applies to:

- Load values valid for holes drilled with TE rotary hammers (without hammering for PPW)
- Correct anchor setting (see instruction for use, setting details)
- Recommended setting machine: SIW 6AT-A
- The ratio of hollow or holes space to solid may not exceed 15 % of a bed joint area
- The brim area around holes must be at least 70mm
- Edge distances, spacing and other influences, see below
- All data given in this section according to Hilti Technical Data

Anchor size			8	10
Nominal embedment depth	$h_{nom}$	[mm]	60	75
Drilling diameter for Mz, KS	$d_0$	[mm]	8	10
Drilling diameter for Vbl, PPW, Leca5®	$d_0$	[mm]	6	8

Anchor size			8	10
			H, C, HF	H, C, HF
Compressive strength class		[N/mm <sup>2</sup> ]	N <sub>rec</sub> Tensile loads	
	Solid clay brick Mz 12 / 2,0 (EN 771-1)	≥ 12	1,4	1,4
		≥ 20	1,8	1,8
	Solid sand-lime brick KS 12 / 2,0 (EN 771-2)	≥ 12	3,7	4,2
		≥ 20	4,8	5,4
	Aerated concrete PPW 6-0,4 (EN 771-4)	≥ 6	1,0	1,6
	Solid lightweight concrete brick Vbl, 2DF (EN 771-3) Solid lightweight concrete brick Leca5® Murblock 19 (EN 771-3)	≥ 5	2,0	2,0

Anchor size			8	10
			H, C, HF	H, C, HF
Compressive strength class		[N/mm <sup>2</sup> ]	V <sub>rec</sub> Shear loads	
	Solid clay brick Mz 12 / 2,0 (EN 771-1)	≥ 12	3,8	5,5
	Solid sand-lime brick KS 12 / 2,0 (EN 771-2)	≥ 12	4,6	5,7
	Aerated concrete PPW 6-0,4 (EN 771-4)	≥ 6	1,3	1,5
	Solid lightweight concrete brick Vbl, 2DF (EN 771-3) Solid lightweight concrete brick Leca5® Murblock 19 (EN 771-3)	≥ 5	2,1	2,8

## Permissible anchor location in brick and block walls

### Edge distance and spacing influence

- The technical data for HUS4 anchors are reference loads for MZ 12, KS 12, Vbl 6, PPW 6 and Leca5®. Due to the large variation of natural stone slid bricks, on site anchor testing is recommended to validate technical data
- The HUS4 anchor was installed and tested in center of solid bricks as shown. The HUS4 anchor was not tested in the mortar joint between solid bricks or in hollow bricks, however a load reduction is expected
- For brick walls where anchor position in brick can not be determined, 100 % anchor testing is recommended
- Distance to free edge free edge to solid masonry (Mz, KS and light weight concrete) units  $\geq 200\text{mm}$
- Distance to free edge free edge to solid masonry (autoclaved aerated gas concrete) units  $\geq 170\text{mm}$
- The minimum distance to horizontal and vertical mortar joint ( $C_{\min}$ ) is started in drawing below
- Minimum anchor spacing ( $s_{\min}$ ) in one brick/block is  $\geq 80\text{ mm}$

### Limits

- All data is for multiple use for non-structural applications
- Plaster, graveling, lining or levelling courses are regarded as non-bearing and may not be taken into account for the calculation of embedment depth
- The decisive resistance to tension loads is the lower value of  $N_{\text{rec}}$  (brick breakout, pull out) and  $N_{\text{max,pb}}$  (pull out of one brick)

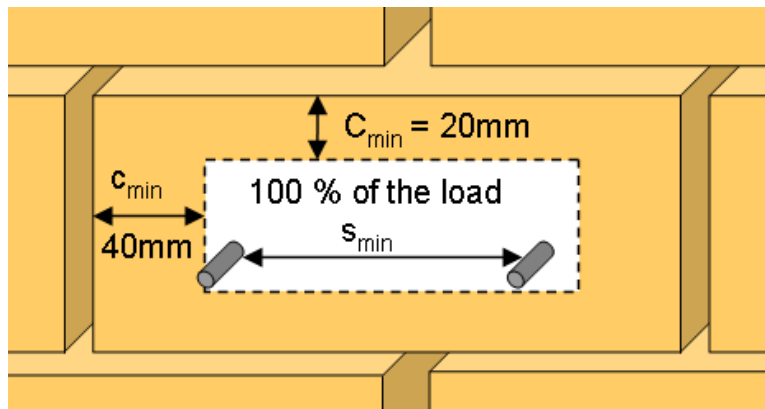

## Basic loading data for single anchor in pre-stressed Hollow core slab (HCS) for permanent fastening

### All data in this section applies to

- Correct anchor setting (see instruction for use, setting details)
- Recommended drilling machine: TE2 A22, recommended setting machine: SIW 6AT-A
- No edge distance and spacing influence
- Ratio core width / web thickness  $\leq 5,3$
- Concrete from C30/37, uncracked
- All data given in this section according to Hilti Technical Data

Anchor size			8	10
Nominal embedment depth	$h_{nom}$	[mm]	$d_b$	$d_b$
Drilling depth	$d_0$	[mm]	$\geq d_b + 10 \text{ mm}$	

### Characteristic resistance

Anchor size		HUS4	8					10				
Concrete strength			C30/37			C45/55		C30/37			C45/55	
Bottom flange thickness	$d_b \geq$	[mm]	30	35	40	35	40	30	35	40	35	40
Tension	$N_{Rk}$	[kN]	2,0	5,8	7,1	7,1	8,7	2,0	5,8	7,1	7,1	8,7
Shear	$V_{Rk}$	[kN]	2,0	9,3	11,4	11,4	14,0	2,0	10,2	12,4	12,5	15,2

### Design resistance

Anchor size		HUS4	8					10				
Concrete strength			C30/37			C45/55		C30/37			C45/55	
Bottom flange thickness	$d_b \geq$	[mm]	30	35	40	35	40	30	35	40	35	40
Tension	$N_{Rd}$	[kN]	1,3	3,2	3,9	4,0	4,8	1,3	3,2	3,9	4,0	4,8
Shear	$V_{Rd}$	[kN]	1,3	6,2	7,6	7,6	9,3	1,3	6,8	8,3	8,3	10,1

### Recommended loads

Anchor size		HUS4	8					10				
Concrete strength			C30/37			C45/55		C30/37			C45/55	
Bottom flange thickness	$d_b \geq$	[mm]	30	35	40	35	40	30	35	40	35	40
Tension	$N_{Rec}$	[kN]	0,95	2,3	2,8	2,9	3,4	0,95	2,3	2,8	2,9	3,4
Shear	$V_{Rec}$	[kN]	0,95	4,4	5,4	5,4	6,6	0,95	4,9	5,9	5,9	7,2

With overall partial safety factor for action  $\gamma = 1,4$ . The partial safety factors for action depend on the type of loading and shall be taken from national regulations.



## Fire resistance for single anchor in pre-stressed Hollow core slab (HCS) for permanent fastening

### All data in this section applies to

- Correct anchor setting (see instruction for use, setting details)
- Recommended drilling machine: TE2 A22, recommended setting machine: SIW 6AT-A
- No edge distance and spacing influence
- Ratio core width / web thickness  $\leq 5,3$
- Concrete from C30/37, uncracked
- Partial safety factor for resistance under fire exposure  $\gamma_{M,fi} = 1,0$  (in absence of other national regulations)
- All data given in this section according to Hilti Technical Data

Anchor size		8	10
Nominal embedment depth	$h_{ef}$ [mm]	$d_b$	$d_b$

### Characteristic resistance

Anchor size	HUS4	8	10	8	10
Concrete strength		C30/37			
Hollow core slab height	$h \geq$ [mm]	265		380	
Bottom flange thickness	$d_b \geq$ [mm]	35		40	
Fire exposure R30	$F_{Rk,fi}$ [kN]	0,26	0,60	0,76	0,80
Fire exposure R60	$F_{Rk,fi}$ [kN]	0,26	0,60	0,76	0,80
Fire exposure R90	$F_{Rk,fi}$ [kN]	0,26	0,60	0,76	0,80
Fire exposure R120	$F_{Rk,fi}$ [kN]	0,26	0,60	0,61	0,80

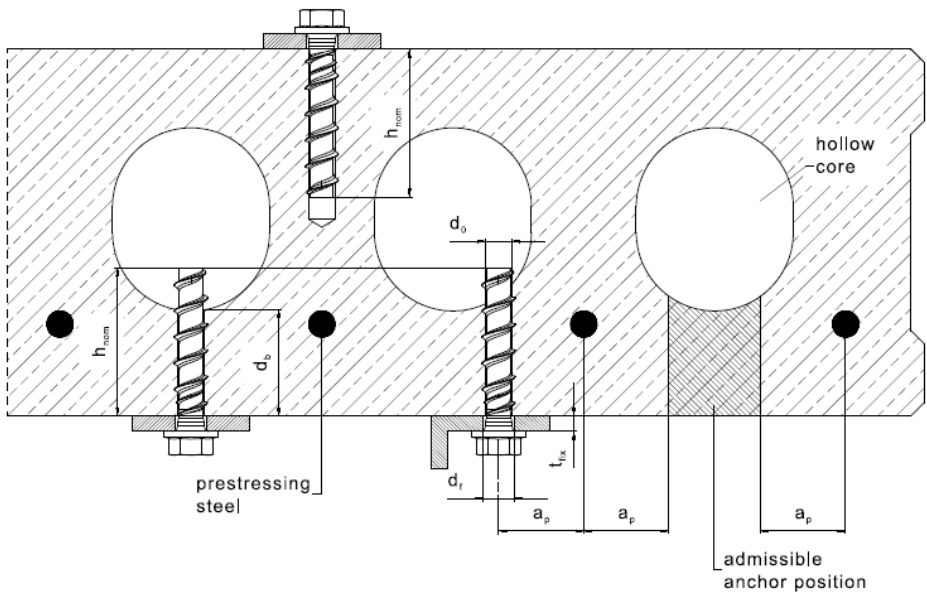

Loads recommendation applies also for installation from top position with no restriction of the admissible anchor position in case of no reinforcement in the related area

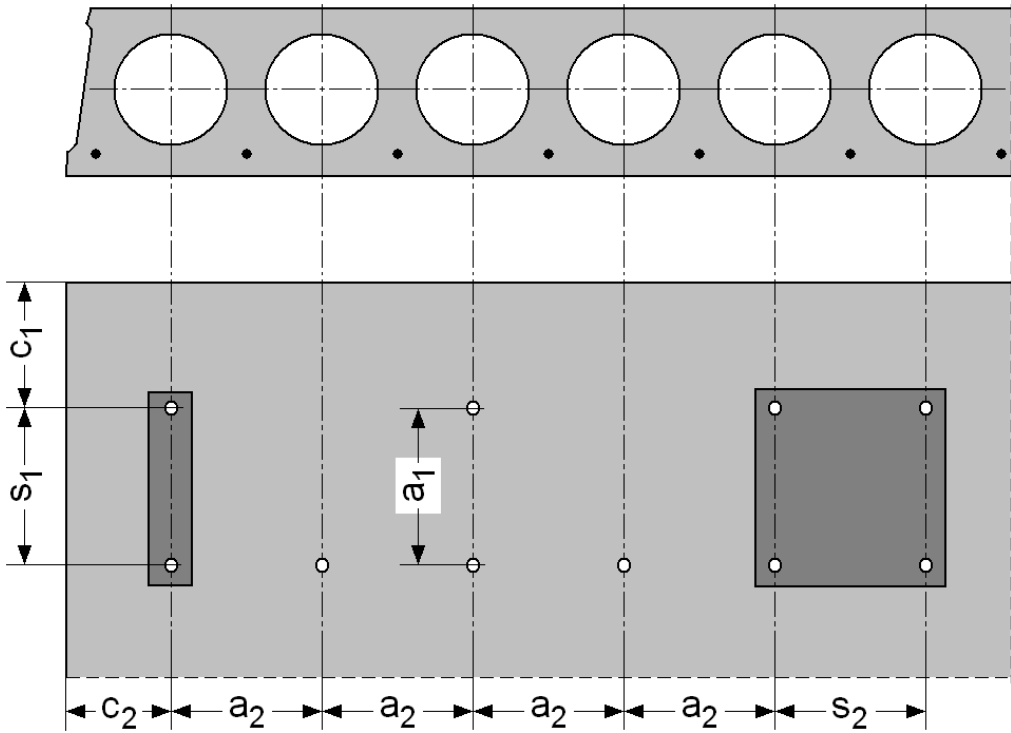

Anchor size		8	10
Type	HUS4	C, H, HF	C, H, HF, A, AF
Minimum and characteristic spacing	$S_{min} = S_{cr}$ [mm]	4 * $d_b$	
Minimum and characteristic edge distance	$C_{min} = C_{cr}$ [mm]	4 * $d_b$	
Minimum group distance	$a_{min}$ [mm]	4 * $d_b$	

Anchor Type	Size [mm]	Length [mm]	$d_b=30$ [mm]		$d_b=35$ [mm]		$d_b=40$ [mm]		$d_b=50$ [mm]	
			$t_{fix,min}$ [mm]	$t_{fix,max}$ [mm]	$t_{fix,min}$ [mm]	$t_{fix,max}$ [mm]	$t_{fix,min}$ [mm]	$t_{fix,max}$ [mm]	$t_{fix,min}$ [mm]	$t_{fix,max}$ [mm]
HUS4-H(F)	8	45	5	10	5	5	-	-	-	-
		55	15	20	15	15	-	-	-	-
		65	5	30	5	25	5	20	5	10
		75	10	40	10	35	10	30	10	20
		85	20	50	20	45	20	40	20	30
		100	35	65	35	60	35	55	35	45
		120	55	85	55	80	55	75	55	65
		150	85	115	85	110	85	105	85	95
HUS4-H(F)	10	60	5	20	5	15	5	10	-	-
		70	15	30	15	25	15	20	-	-
		80	5	40	5	35	5	30	5	20
		90	10	50	10	45	10	40	10	30
		100	20	60	20	55	20	50	20	40
		110	30	70	30	65	30	60	30	50
		130	50	90	50	85	50	80	50	70
		150	70	110	70	105	70	100	70	90

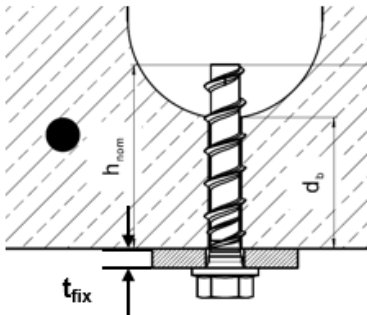

### Setting instructions

\*For detailed information on installation see instruction for use given with the package of the product  
**Installation in Hollow core slabs - example size 10**

**Basic loading data for single anchor in pre-stressed Hollow core slab (HCS) for temporary fastening**

**All data in this section applies to**

- Correct setting (see setting instruction)
- Verification of wear of the screw with HUS HRG check gauge is needed

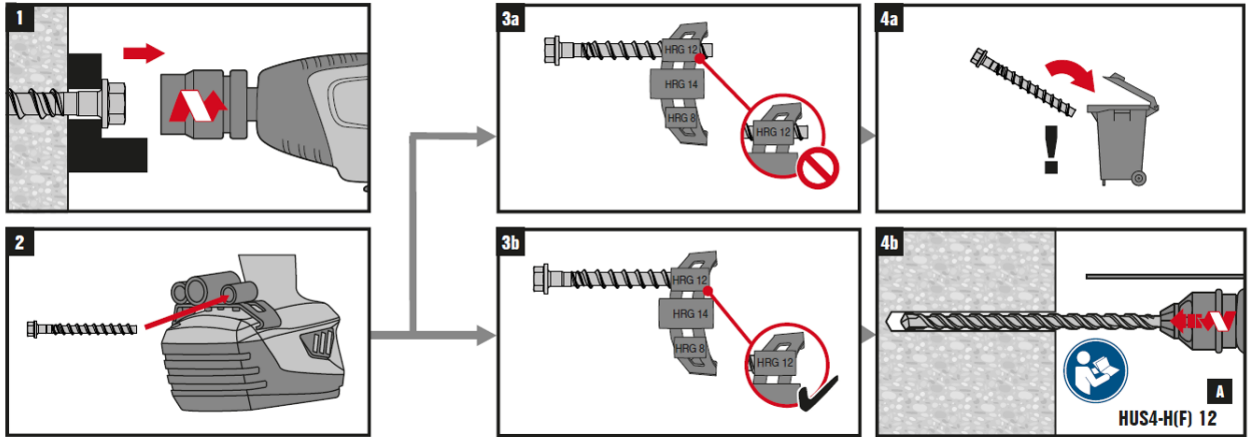

- No edge distance and spacing influence
- Ratio core width / web thickness  $w/e \leq 5,3$
- Concrete C30/37 to C50/60, uncracked

**Installation position for temporary fastening in HCS:**

- Top position of the slab is allowed.
- Anchor to be installed within position of  $\pm 10$  mm of the thickest section of the solid part.

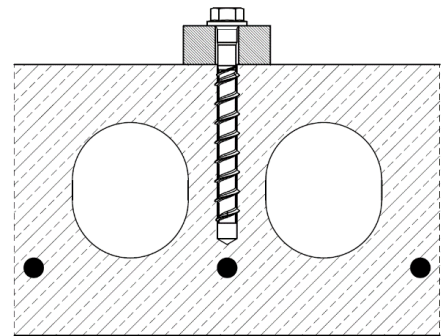

Anchor size		10	12	14
Nominal embedment depth	$h_{nom}$ [mm]	55 / 75 / 85	60 / 80 / 100	65 / 85 / 115
Drill hole depth	$h_1 \geq$ [mm]	$h_{nom} + 10$ mm		



**Characteristic resistance: Concrete C30/37**

Anchor size			10			12			14		
Type			A, AF, C, H, HF			H			A, AF, H, HF		
Nom. embedment depth	$h_{nom}$	[mm]	55	75	85	60	80	100	65	85	115
Tension	$N_{Rk}$	[kN]	14,3	22,1	23,6	16,9	24,0	30,1	18,2	26,5	37,6
Shear	$V_{Rk}$	[kN]	15,0	25,1	26,4	23,3	28,3	33,3	25,5	31,4	37,0

**Design resistance: Concrete C30/37**

Anchor size			10			12			14		
Type			A, AF, C, H, HF			H			A, AF, H, HF		
Nom. embedment depth	$h_{nom}$	[mm]	55	75	85	60	80	100	65	85	115
Tension	$N_{Rd}$	[kN]	9,6	14,7	15,8	11,2	16,0	20,1	12,1	17,7	25,1
Shear	$V_{Rd}$	[kN]	10,0	16,7	17,6	15,5	18,8	22,2	17,0	20,9	24,7

**Recommended load: Concrete C30/37**

Anchor size			10			12			14		
Type			A, AF, C, H, HF			H			A, AF, H, HF		
Nom. embedment depth	$h_{nom}$	[mm]	55	75	85	60	80	100	65	85	115
Tension	$N_{Rec}$	[kN]	6,8	10,5	11,3	8,0	11,4	14,3	8,7	12,6	17,9
Shear	$V_{Rec}$	[kN]	7,2	12,0	12,6	11,1	13,5	15,9	12,1	15,0	17,6

With overall partial safety factor for action  $\gamma = 1,4$ . The partial safety factors for action depend on the type of loading and shall be taken from national regulations.

**Characteristic resistance: Concrete C45/55**

Anchor size			10			12			14		
Type			A, AF, C, H, HF			H			A, AF, H, HF		
Nom. embedment depth	$h_{nom}$	[mm]	55	75	85	60	80	100	65	85	115
Tension	$N_{Rk}$	[kN]	17,6	27,1	29,0	20,7	29,4	36,9	22,3	32,5	46,1
Shear	$V_{Rk}$	[kN]	18,4	25,1	26,4	23,3	28,3	33,3	25,9	31,4	37,0

**Design resistance: Concrete C45/55**

Anchor size			10			12			14		
Type			A, AF, C, H, HF			H			A, AF, H, HF		
Nom. embedment depth	$h_{nom}$	[mm]	55	75	85	60	80	100	65	85	115
Tension	$N_{Rd}$	[kN]	11,7	18,1	19,3	13,8	19,6	24,6	14,9	21,7	30,7
Shear	$V_{Rd}$	[kN]	12,3	16,7	17,6	15,5	18,8	22,2	17,3	20,9	24,7

**Recommended load: Concrete C45/55**

Anchor size			10			12			14		
Type			A, AF, C, H, HF			H			A, AF, H, HF		
Nom. embedment depth	$h_{nom}$	[mm]	55	75	85	60	80	100	65	85	115
Tension	$N_{Rec}$	[kN]	8,4	12,9	13,8	9,8	14,0	17,6	10,6	15,5	21,9
Shear	$V_{Rec}$	[kN]	8,8	12,0	12,6	11,1	13,5	15,9	12,3	15,0	17,6

With overall partial safety factor for action  $\gamma = 1,4$ . The partial safety factors for action depend on the type of loading and shall be taken from national regulations.

**Anchor spacing and edge distance**

Anchor size			10			12			14		
Type			A, AF, C, H, HF			H			A, AF, H, HF		
Minimum spacing	$s_{min}$	[mm]	40			50			60		
Characteristic spacing	$s_{cr}$	[mm]	3 * $h_{ef}$								
Minimum edge distance	$c_{min}$	[mm]	40			50			60		
Characteristic edge distance	$c_{cr}$	[mm]	1,5 * $h_{ef}$								