



HAP 2.5 HOIST ANCHOR PLATE

Technical Datasheet (UE version)

Update: 03-2022



HAP 2.5 Hoist Anchor Plate

Hoist Anchor Plate with 2.5 t WLL capacity for elevator shaft operations

Anchor version



HAP 2.5
+
HST3



HAP 2.5
+
HUS3

Benefits

- 2.5 t WLL capacity according to Machinery Directive 2006/42/EC.
- Anchorage of hoist to be designed with PROFIS Anchor software for cracked and uncracked concrete, \geq C20/25, according to EC2 and ETAG (No. 001 Annex C/2010).
- Recommended and designed for anchorage with anchors:
 - HST3 M12x115 ($h_{nom}=80mm$)
 - HUS3 H10x110 ($h_{nom}=85mm$)
- Delivered pre-assembled (one piece) with combo options available: HAP 2.5 + Anchors (4xHST3 or 4xHUS3).
- Lightweight: One person installation possible at overhead position total weight < 3Kg.
- No rotation of hook point allowed preventing swiveling.
- Large hooking area for easy engagement. Hook point: $\varnothing > 90mm$.
- Compact design for narrow spaces: rigid height < 56mm.
- Printed IFU on the product for immediate clarification.
- < 45° loading allowed in all directions.

Base material



Concrete
(non-cracked)



Concrete
(cracked)

Other information



PROFIS
Anchor design
Software

Applications

HAP 2.5 is designed to be used as post installed “master hoist point” for installation and/or maintenance in elevator shafts under static and quasi-static loading. In case of fatigue loading see TWU72/18. It can be used with manual or motor hoists and bears a working load up to 2.5 tons in variable directions.

Warning

	<p>Men riding (Car-top Lift-installation Method) (worker and material on top of the cabin) In case the main hoist point fails, the platform falls ~0.3m until the elevator safety-gears will automatically activate bringing the elevator cabin to a complete stop. Emergency brakes need to be activated.</p>
--	--

Basic loading data

Data for max 2.5 t WLL capacity applies to HAP 2.5 only when:

- Correct design of anchorage (see “design of anchorage”)
- Installation and anchor setting according to IFU from HAP 2.5t and corresponding anchor (HUS3 or HST3)
- No shock loading; vibratory dynamic safety factor γ_{dyn} up to 1.8

HAP Working Load Limitation (WLL)^{a) b)}

	<p style="text-align: center;">Load type</p> <p style="text-align: center;">Single Point</p>
$45^\circ < \alpha < 135^\circ$ WLL _{total} [metric ton]	2,5

a) In accordance with machinery safety directive 2006/42/EC the following working coefficients were implemented:

- Working coefficient of all metal components: $\gamma = 4$
- Working coefficient of the cables: $\gamma = 5$

b) Data valid (including hoist and anchors) for static loading and fatigue cycling loading and a number of cycles $N_{cyclesK} < 1000$ under pure tension or up to a load inclination of 45° , see test report TWU72/18.

Data valid (hoist only) for static loading and fatigue cycling loading and a number of cycles $1000 < N_{cyclesK} < 10000$ under pure tension or up to a load inclination of 45° . Anchors must be verified separately. For further details please contact you Hilti account manager and see test report TWU72/18.

Materials

Material quality

Part	Material / Mechanical properties or standard
Carrier plate	Rm 700-900 Mpa – 5 μ m Geomet 321A
Wire rope $\phi 11 \times 150 - 6 \times 36 \text{WS IWRC}$	Rope: steel 1960 MPa, zinc plated / ferrule: Alu
Holder	Low carbon steel – 5 μ m Geomet 321A
Blind rivet DIN EN ISO 15977 – 6.4x18	Stainless steel

Dimensions

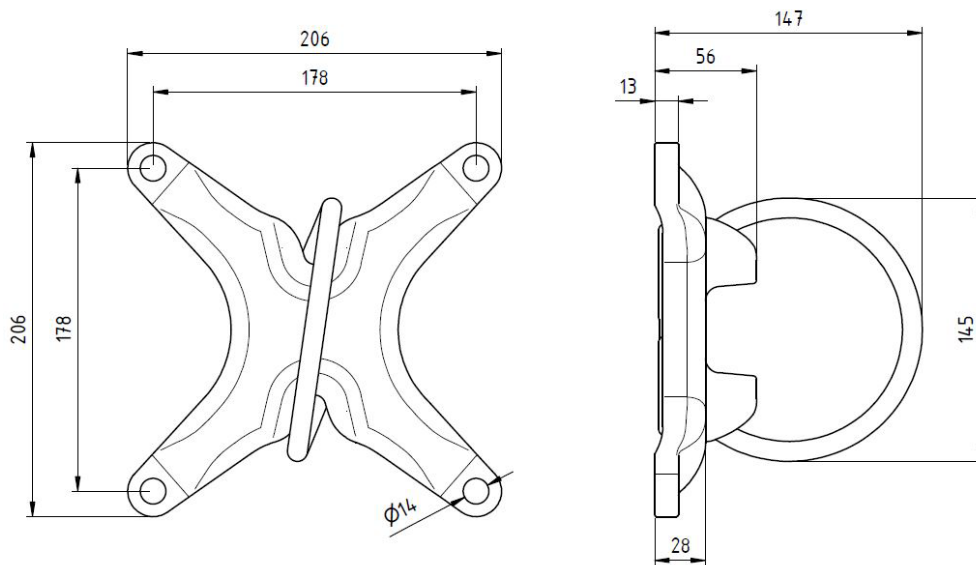

Onsite qualification

HAP 2.5 is designed for temporary & permanent application under dry indoor conditions.

Recommended tools to do onsite qualification: Anchor Tester HAT 28-E (#386372) with HAT Kit HAP 2.5 (#2301103).

Installation instructions

- 1) Install the anchors according to the Hilti Instruction for use. Only HST3 M12 with $h_{nom} \geq 80\text{mm}$ and HUS3 H10 with $h_{nom} \geq 85\text{mm}$ are qualified. Make sure HAP 2.5 is correctly installed, according to the Instruction for use of the HAP 2.5. Set up the HAT 28E according to the manual provided with the anchors tester. Set bridge legs to right heights. (*Image 1*). Then, connect the ring bolt adapter to steel wire rope. Always use the provide steel disc as shown in *Image 2*. Not using it could result in unallowed bending of the wire. Thus damaging the HAP 2.5. A HAP 2.5 with a bent wire is not safe for use.



Image 1



Image 2

- 2) Connect HAT 28-E with ring bolt adapter and make sure the bridge of the tester is parallel to the concrete surface as well as to the HAP 2.5 base (*Image 3*). Check if the baseplate can be moved versus the concrete. It needs to be firm. Turn crank in clockwise direction until legs in contact with base material bring the system to a still situation (without starting the loading process). Check and make sure pullout force acts parallel to axis of anchors and to the legs of tester. HAP 2.5 must remain centered in the both parallel and perpendicular direction of the tester.



Image 3

3) Set the red handle of the analogue gauge to zero in order to be able to start the measurement. (Image 4).



Image 4

4) Hold the HAT 28-E by the grip while increasing the load of the HAP 2.5 by turning the crank (or with spanner wrench on hexagon nut on top of tester) in a clockwise direction. Increase the load until desired proof load is attained. Image 5. Do not exceed the maximum allowable load of the tester of 30kN!



Image 5

5) Keep the proof load on HAP 2.5 for the desired time. Do not keep retightening if the loading relaxes during this time. The displacement is not allowed to increase in this time.



6) (Image 6)

Release the load by turning the crank counterclockwise



Image 6

7) Remove HAT 28-E and ring bolt adapter.

8) Perform visual check on HAP 2.5 and base material (Image 7).

Check if the baseplate is still firmly pressed to the concrete. If baseplate is loose, re-tight anchors and repeat procedure from the beginning.

We recommend **NOT TO USE** the tested HAP 2.5 when:

- The baseplate is loose also after repeated test.
- If the base material shows cracks during and or after the test around the HAP 2.5. It could be the sign of an overload of the concrete.
- If the HAP is damaged or deformed or the cable is bent.

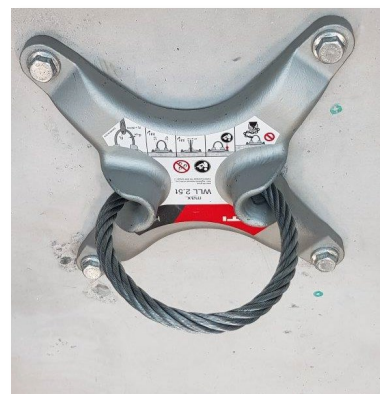



Image 7

In these cases set a new point in a different position and repeat procedure from the beginning.	
9) If the testing was successful mark or label the HAP 2.5 according to your requirements.	

Design of anchorage

An exemplary calculation under static considerations of a Hoist with different Hilti anchoring products designed with Hilti Profis engineering can be found below while the Input data applies. In case of different design conditions a new calculation should be performed.

HAP 2.5 is designed to be used as hoist point for lifting loads under variable directions in elevator installation or maintenance. The design of an anchorage for the HAP 2.5 must be ensured for varying load conditions (varying directions, dynamic effects, etc.). For this the anchorage for HAP 2.5 has to be designed according to extreme load cases: a concrete anchor can only be considered as suitable for use with the HAP 2.5 hoist point if the approved anchor satisfies the following load scenarios (e.g. by PROFIS calculation) with EC2-4 calculation method. It has to be done in accordance with the relevant codes/ETAs for each application case separately.

HAP 2.5 t + HST3 M12 – Pure tension

$N = \text{Action} = 2,5\text{t (WLL)} \times 1,8 (\gamma_{\text{dyn}}) = 45 \text{ kN}$

1 Input data

Anchor type and size:	HST3 M12 hef2
Item number:	2105719 HST3 M12x115 40/20
Effective embedment depth:	$h_{ef} = 70.0 \text{ mm}$, $h_{nom} = 80.0 \text{ mm}$
Material:	
Approval No.:	ETA-98/0001
Issued Valid:	09/02/2018 -
Proof:	Design Method ETAG (No. 001 Annex C/2010)
Stand-off installation:	$e_b = 0.0 \text{ mm}$ (no stand-off); $t = 11.0 \text{ mm}$
Baseplate ^R :	$l_x \times l_y \times t = 220.0 \text{ mm} \times 220.0 \text{ mm} \times 11.0 \text{ mm}$; (Recommended plate thickness: not calculated)
Profile:	Cylinder, 10; (L x W x T) = 10.0 mm x 10.0 mm
Base material:	cracked concrete, C20/25, $f_{c,cube} = 25.00 \text{ N/mm}^2$; $h = 150.0 \text{ mm}$
Installation:	hammer drilled hole, Installation condition: Dry
Reinforcement:	No reinforcement or Reinforcement spacing $\geq 150 \text{ mm}$ (any \varnothing) or $\geq 100 \text{ mm}$ ($\varnothing \leq 10 \text{ mm}$) no longitudinal edge reinforcement Reinforcement to control splitting according to ETAG 001, Annex C, 5.2.2.6 present.



^R - The anchor calculation is based on a rigid baseplate assumption.

Geometry [mm] & Loading [kN, kNm]

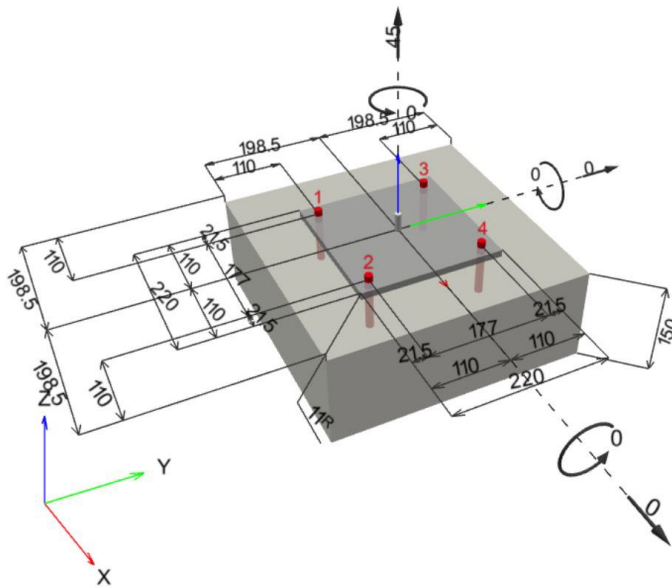

1.1 Load combination

Case	Description	Forces [kN] / Moments [kNm]	Seismic	Fire	Max. Util. Anchor [%]
1	Combination 1	N = 45.000; V _x = 0.000; V _y = 0.000; M _x = 0.000; M _y = 0.000; M _z = 0.000;	no	no	95

2 Load case/Resulting anchor forces

Load case: Design loads

Anchor reactions [kN]

Tension force: (+Tension, -Compression)

Anchor	Tension force	Shear force	Shear force x	Shear force y
1	11.250	0.000	0.000	0.000
2	11.250	0.000	0.000	0.000
3	11.250	0.000	0.000	0.000
4	11.250	0.000	0.000	0.000

max. concrete compressive strain: - [%]
 max. concrete compressive stress: - [N/mm²]
 resulting tension force in (x/y)=(0.0/0.0): 45.000 [kN]
 resulting compression force in (x/y)=(0.0/0.0): 0.000 [kN]

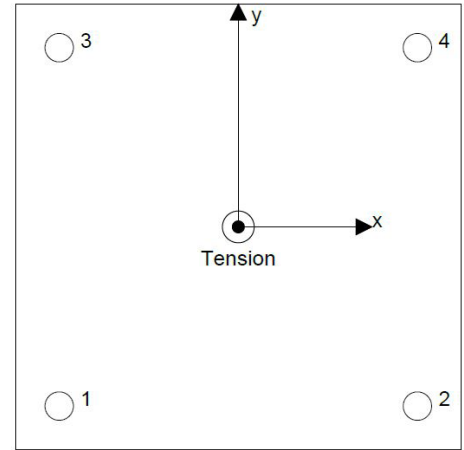

Anchor forces are calculated based on the assumption of a rigid baseplate.

HAP 2.5 t + HST3 M12 – 45° angle

$$N = N_t \times \sin 45^\circ = 32 \text{ kN}$$

$$V_x = N_t \times \cos 45^\circ = 32 \text{ kN}$$

1 Input data

Anchor type and size:	HST3 M12 hef2
Item number:	2105719 HST3 M12x115 40/20
Effective embedment depth:	$h_{ef} = 70.0 \text{ mm}$, $h_{nom} = 80.0 \text{ mm}$
Material:	
Approval No.:	ETA-98/0001
Issued I Valid:	09/02/2018 -
Proof:	Design Method ETAG (No. 001 Annex C/2010)
Stand-off installation:	$e_b = 0.0 \text{ mm}$ (no stand-off); $t = 11.0 \text{ mm}$
Baseplate ^R :	$l_x \times l_y \times t = 220.0 \text{ mm} \times 220.0 \text{ mm} \times 11.0 \text{ mm}$; (Recommended plate thickness: not calculated)
Profile:	Cylinder, 10; (L x W x T) = 10.0 mm x 10.0 mm
Base material:	cracked concrete, C20/25, $f_{c,cube} = 25.00 \text{ N/mm}^2$; $h = 150.0 \text{ mm}$
Installation:	hammer drilled hole, Installation condition: Dry
Reinforcement:	No reinforcement or Reinforcement spacing $\geq 150 \text{ mm}$ (any \emptyset) or $\geq 100 \text{ mm}$ ($\emptyset \leq 10 \text{ mm}$) no longitudinal edge reinforcement Reinforcement to control splitting according to ETAG 001, Annex C, 5.2.2.6 present.



^R - The anchor calculation is based on a rigid baseplate assumption.

Geometry [mm] & Loading [kN, kNm]

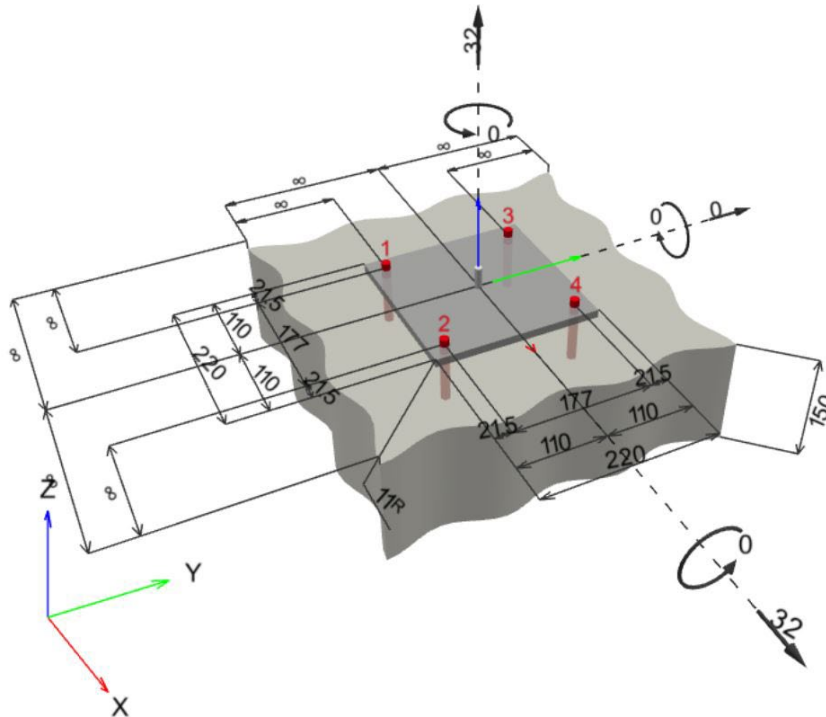

1.1 Load combination

Case	Description	Forces [kN] / Moments [kNm]	Seismic	Fire	Max. Util. Anchor [%]
1	Combination 1	N = 32.000; V _x = 32.000; V _y = 0.000; M _x = 0.000; M _y = 0.000; M _z = 0.000;	no	no	70

2 Load case/Resulting anchor forces

Load case: Design loads

Anchor reactions [kN]

Tension force: (+Tension, -Compression)

Anchor	Tension force	Shear force	Shear force x	Shear force y
1	8.000	8.000	8.000	0.000
2	8.000	8.000	8.000	0.000
3	8.000	8.000	8.000	0.000
4	8.000	8.000	8.000	0.000

max. concrete compressive strain: - [%]
 max. concrete compressive stress: - [N/mm²]
 resulting tension force in (x/y)=(0.0/0.0): 32.000 [kN]
 resulting compression force in (x/y)=(0.0/0.0): 0.000 [kN]

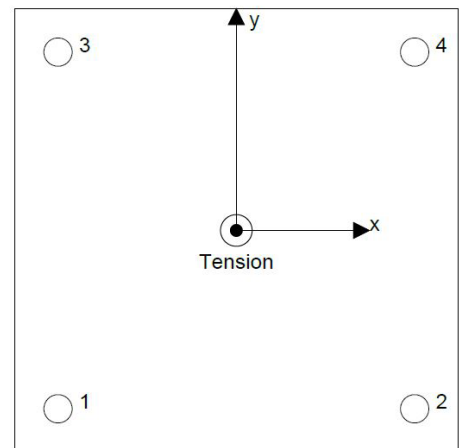

Anchor forces are calculated based on the assumption of a rigid baseplate.

HAP 2.5 t + HUS3 H10 – Pure tension

N= Action = 2,5t (WLL) x 1,8 (γ_{dyn}) = 45 kN

1 Input data

Anchor type and size:	HUS3-H 10 h_nom3
Item number:	2079915 HUS3-H 10x100 45/25/15
Effective embedment depth:	$h_{ef} = 67.1$ mm, $h_{nom} = 85.0$ mm
Material:	1.5525
Approval No.:	ETA-13/1038
Issued I Valid:	27/04/2018 -
Proof:	Design Method ETAG (No. 001 Annex C/2010)
Stand-off installation:	$e_b = 0.0$ mm (no stand-off); $t = 11.0$ mm
Baseplate ^R :	$l_x \times l_y \times t = 220.0$ mm x 220.0 mm x 11.0 mm; (Recommended plate thickness: not calculated)
Profile:	Cylinder, 10; (L x W x T) = 10.0 mm x 10.0 mm
Base material:	cracked concrete, C20/25, $f_{c,cube} = 25.00$ N/mm ² ; $h = 150.0$ mm
Installation:	hammer drilled hole, Installation condition: Dry
Reinforcement:	No reinforcement or Reinforcement spacing ≥ 150 mm (any \varnothing) or ≥ 100 mm ($\varnothing \leq 10$ mm) no longitudinal edge reinforcement Reinforcement to control splitting according to ETAG 001, Annex C, 5.2.2.6 present.



^R - The anchor calculation is based on a rigid baseplate assumption.

Geometry [mm] & Loading [kN, kNm]

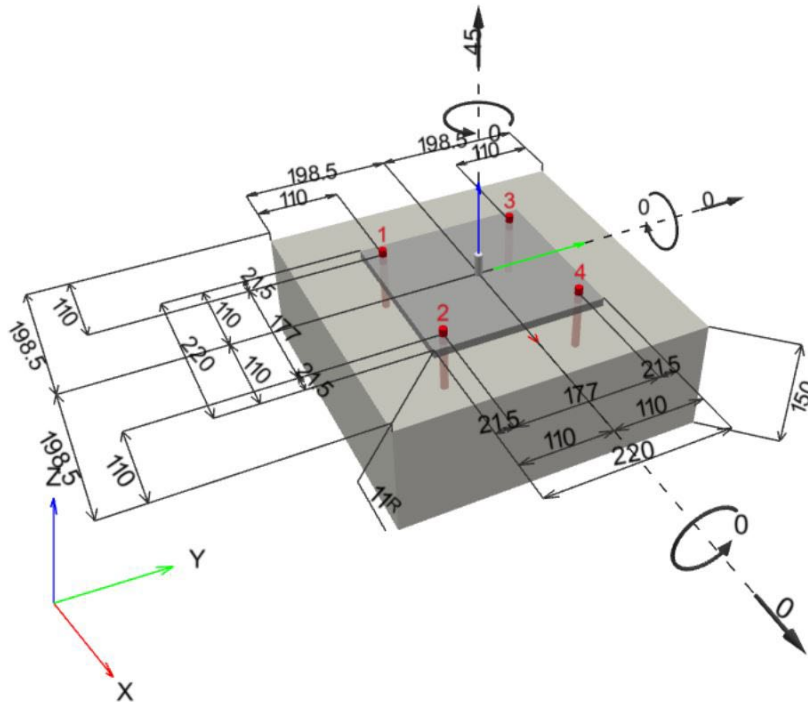

1.1 Load combination

Case	Description	Forces [kN] / Moments [kNm]	Seismic	Fire	Max. Util. Anchor [%]
1	Combination 1	N = 45.000; V _x = 0.000; V _y = 0.000; M _x = 0.000; M _y = 0.000; M _z = 0.000;	no	no	97

2 Load case/Resulting anchor forces

Load case: Design loads

Anchor reactions [kN]

Tension force: (+Tension, -Compression)

Anchor	Tension force	Shear force	Shear force x	Shear force y
1	11.250	0.000	0.000	0.000
2	11.250	0.000	0.000	0.000
3	11.250	0.000	0.000	0.000
4	11.250	0.000	0.000	0.000

max. concrete compressive strain: - [%]
 max. concrete compressive stress: - [N/mm²]
 resulting tension force in (x/y)=(0.0/0.0): 45.000 [kN]
 resulting compression force in (x/y)=(0.0/0.0): 0.000 [kN]

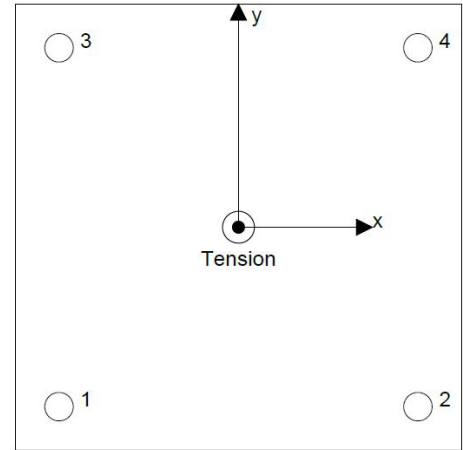

Anchor forces are calculated based on the assumption of a rigid baseplate.

HAP 2.5 t + HUS3 H10 – 45° angle

$$N = N_t \times \sin 45^\circ = 32 \text{ kN}$$

$$V_x = N_t \times \cos 45^\circ = 32 \text{ kN}$$

1 Input data

Anchor type and size:	HUS3-H 10 h _{nom} 2
Item number:	2079914 HUS3-H 10x90 35/15/5
Effective embedment depth:	h _{ef} = 58.6 mm, h _{nom} = 75.0 mm
Material:	1.5525
Approval No.:	ETA-13/1038
Issued Valid:	27/04/2018 -
Proof:	Design Method ETAG (No. 001 Annex C/2010)
Stand-off installation:	e _b = 0.0 mm (no stand-off); t = 11.0 mm
Baseplate ^R :	l _x x l _y x t = 220.0 mm x 220.0 mm x 11.0 mm; (Recommended plate thickness: not calculated)
Profile:	Cylinder, 10; (L x W x T) = 10.0 mm x 10.0 mm
Base material:	cracked concrete, C20/25, f _{c,cube} = 25.00 N/mm ² ; h = 150.0 mm
Installation:	hammer drilled hole, Installation condition: Dry
Reinforcement:	No reinforcement or Reinforcement spacing >= 150 mm (any Ø) or >= 100 mm (Ø <= 10 mm) no longitudinal edge reinforcement Reinforcement to control splitting according to ETAG 001, Annex C, 5.2.2.6 present.



^R - The anchor calculation is based on a rigid baseplate assumption.

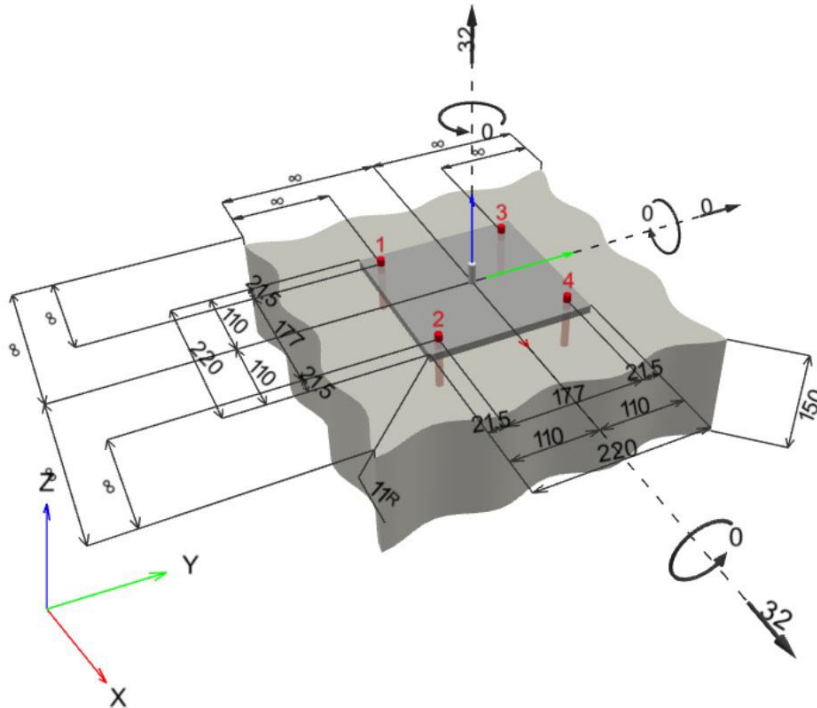

1.1 Load combination

Case	Description	Forces [kN] / Moments [kNm]	Seismic	Fire	Max. Util. Anchor [%]
1	Combination 1	N = 32.000; V _x = 32.000; V _y = 0.000; M _x = 0.000; M _y = 0.000; M _z = 0.000;	no	no	100

2 Load case/Resulting anchor forces

Load case: Design loads

Anchor reactions [kN]

Tension force: (+Tension, -Compression)

Anchor	Tension force	Shear force	Shear force x	Shear force y
1	8.000	8.000	8.000	0.000
2	8.000	8.000	8.000	0.000
3	8.000	8.000	8.000	0.000
4	8.000	8.000	8.000	0.000

max. concrete compressive strain: - [%]
 max. concrete compressive stress: - [N/mm²]
 resulting tension force in (x/y)=(0.0/0.0): 32.000 [kN]
 resulting compression force in (x/y)=(0.0/0.0): 0.000 [kN]

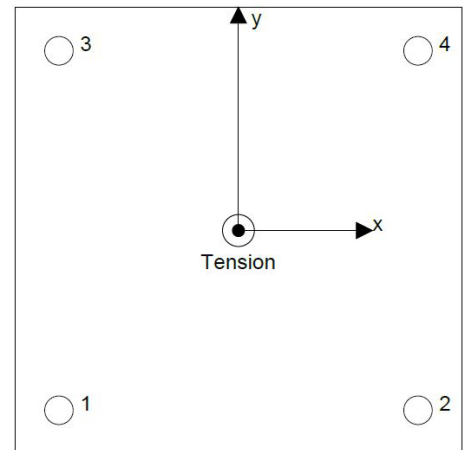

Anchor forces are calculated based on the assumption of a rigid baseplate.

Setting information

Setting parameters

Parameter			HAP 2.5
Minimum base material thickness	h_{\min}	[mm]	According to technical data of applied anchors
Spacing (Hoist Anchor Plate)	s	[mm]	178
Edge distance	c	[mm]	According to technical data of applied anchors ^{a)}

a) For smaller edge distances the design loads have to be reduced (see ETAG 001, Annex C).

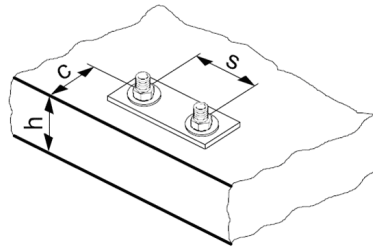

Inspection criteria

Caution: The attachment point must be in a good operating condition and undamaged. Broken wires, signs of corrosion, visible distortions or deformations are unacceptable.

Caution: The shaft ceiling, particularly the concrete, must be in sound condition. Any visible cracking, blow out or signs of corrosion are unacceptable.

Caution: Do not use an attachment point which has an unreadable or missing identification label.

Setting instructions

*For detailed information on installation see instruction for use given with the package of the product.

Setting instruction for HAP 2.5

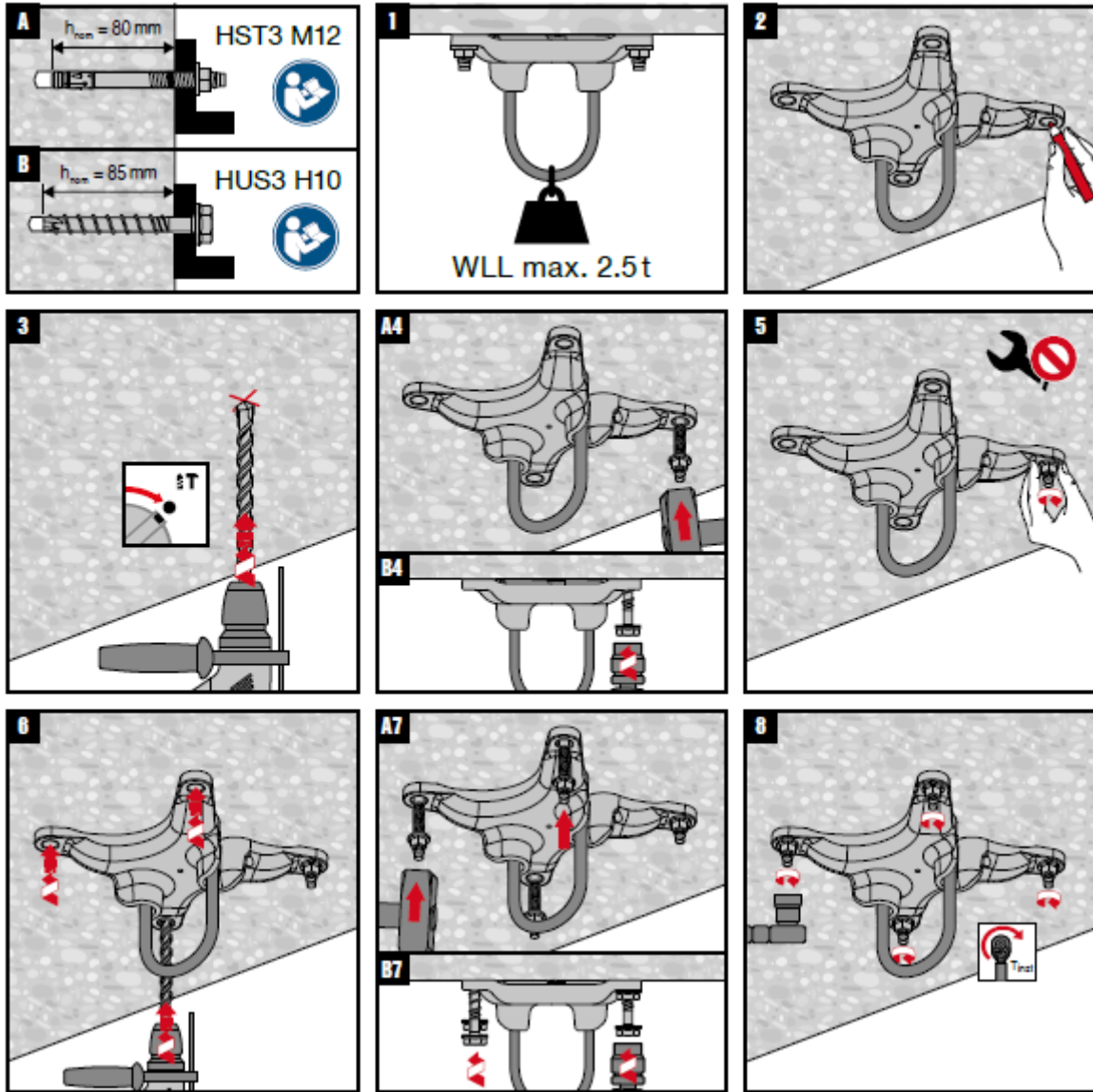

Caution

