

WALL TO WALL JOINT : CONCRETE OR BLOCK WALL TO CONCRETE OR BLOCK WALL

ASSEMBLY RATING = 2-HR.

CLASS II MOVEMENT CAPABILITIES - 12.5% COMPRESSION OR EXTENSION

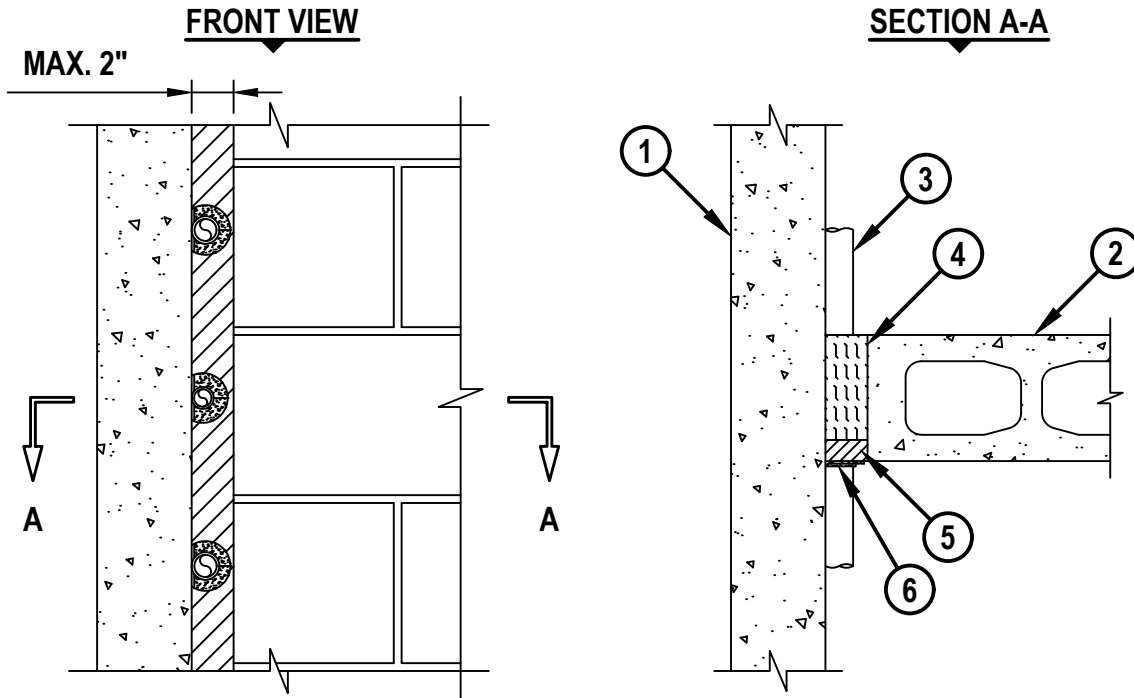

WWD0220b.050820

1. CONCRETE WALL ASSEMBLY (2-HR. FIRE-RATING) :
 - A. LIGHTWEIGHT OR NORMAL WEIGHT CONCRETE WALL (MINIMUM 4-1/2" THICK).
 - B. ANY UL CLASSIFIED CONCRETE BLOCK WALL.
2. CONCRETE WALL ASSEMBLY (2-HR. FIRE-RATING) :
 - A. LIGHTWEIGHT OR NORMAL WEIGHT CONCRETE WALL (MINIMUM 6" THICK).
 - B. ANY UL CLASSIFIED CONCRETE BLOCK WALL.
3. [OPTIONAL] ONE OR MORE PENETRANTS CONSISTING OF THE FOLLOWING :
 - A. MAXIMUM 1" NOMINAL DIAMETER STEEL CONDUIT.
 - B. MAXIMUM 1" NOMINAL DIAMETER PVC CONDUIT (SCH 40).
4. MINIMUM 5" THICKNESS MINERAL WOOL SAFING (MIN. 4 PCF DENSITY) COMPRESSED 50%, FLUSH WITH ONE SIDE OF WALL AND RECESSED FROM OPPOSITE SIDE TO ACCOMMODATE SEALANT.
5. MINIMUM 1" DEPTH HILTI CP 606 FLEXIBLE FIRESTOP SEALANT.
6. HILT CFS-D 1" FIRESTOP PUTTY DISC PRESSED FIRMLY AROUND PENETRANT AND OVER FIRESTOP SEALANT AT JOINT FACE. ONE PUTTY DISC INSTALLED ON EACH PENETRATING ITEM.

NOTES : 1. MAXIMUM WIDTH OF JOINT = 2".
 2. ANNULAR SPACE (PENETRANTS TO WALL, ITEM NO. 1) = NOMINAL 0".
 3. ANNULAR SPACE (PENETRANTS TO OPPOSING WALL WALL, ITEM NO. 2) = MINIMUM 5/8".
 4. ANNULAR SPACE (BETWEEN PENETRANTS) = MINIMUM 8".



HILTI, Inc.
 Plano, Texas USA (800) 879-8000

Sheet	1 of 1
Scale	1/8" = 1"
Date	May 08, 2020

Drawing No.
**WWD
 0220b**