



HUS4 Screw anchor

Product Technical Datasheet

Metal decks

Steel-to-concrete

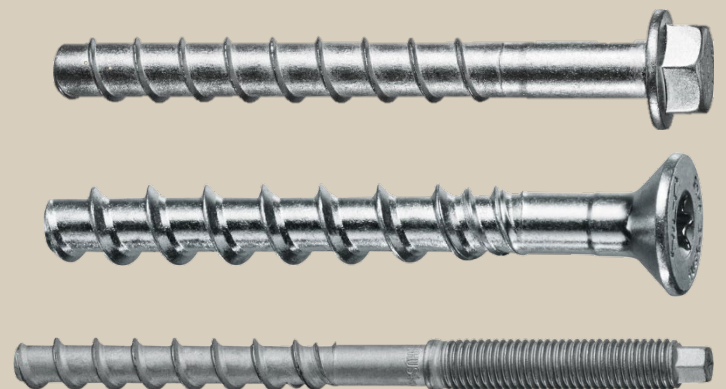

Update: Sep 24



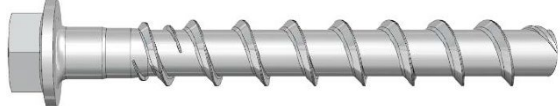

HUS4 Screw anchor for use with metal decks in concrete

High performance screw anchor for single point fastening into ComFlor® 60, 80 and SR

Anchor version	Benefits
 <p>HUS4-H(F) (8-10)</p>	<ul style="list-style-type: none"> - High productivity - less drilling and fewer operations than with conventional anchors
 <p>HUS4-C (8-10)</p>	<ul style="list-style-type: none"> - Two embedment depths for design flexibility and flexible design for concrete cone capacity
 <p>HUS4-A(F) (10)</p>	<ul style="list-style-type: none"> - No cleaning required for size 8 and 10 - HUS4-HF and HUS4-AF with multilayer coatings for additional corrosion protection - Through fastening with H, A and C head - Pre-fastening with A head



Base material	Load conditions
<div style="display: flex; justify-content: space-around;"> <div data-bbox="140 1603 256 1715"> <p>Concrete (uncracked)</p> </div> <div data-bbox="309 1603 426 1715"> <p>Concrete (cracked)</p> </div> </div>	<div style="display: flex; justify-content: space-around;"> <div data-bbox="823 1603 941 1715"> <p>Static / quasi-static</p> </div> <div data-bbox="995 1603 1114 1715"> <p>Seismic, C1</p> </div> </div>
<p>Drilling, cleaning, setting</p> <div data-bbox="148 1868 261 1980"> <p>Hammer drilled holes</p> </div>	<p>Other information</p> <div data-bbox="823 1899 941 1951"> </div> <p>Hilti Technical data</p>







Instructions for use

The instructions for use can be viewed using the link in the instructions for use table or the QR code/link in the Hilti webpage table.

Instructions for use (IFU)

Anchor size	8	10
H, HF	IFU HUS4-H(F)-8	IFU HUS4-H(F)-10
C	IFU HUS4-C-8	IFU HUS4-C-10
A, AF	-	IFU HUS4-A-10
Filling set	IFU Filling set	

Link to Hilti Webpage

HUS4-H	HUS4-HF	HUS4-C	HUS4-A	HUS4-AF	Filling set
					

Static and quasi-static loading based on Hilti technical data. Design according to EN 1992-4

All data in this section applies to:

- Correct setting (see setting instruction)
- Hammer drilled holes
- For a single anchor
- No edge distance and spacing influence (see setting detail tables with characteristic distances). Only one anchor can be used in the lower flute at a time with the min. spacing between anchors along the length of the flute to be at least $s = 3 h_{ef}$. This datasheet does not give information for the design of fasteners in a group.
- Minimum base material thickness (see setting detail table)
- Embedment depth, as specified in the table of this section
- Concrete from C30/37 without steel fiber for higher compressive strengths, the tension resistance may be increased by $(f'c / 30)^{0,5}$
- Recommended loads: With overall partial safety factor for action $\gamma = 1,4$.

For anchoring into the upper flute, either use table below conservatively or refer to ETA-20/0867. In this case the minimum required slab thickness h_{min} must be larger than the deck thickness $h_{min,deck}$.

Design resistance

Type	HUS4	H, HF, C		H, HF, C, A, AF	
Anchor size		8		10	
Nominal embedment depth h_{nom} [mm]		60	70	75	85
Uncracked concrete					
Tension N_{Rd} [kN]		10,6	11,7	12,8	13,3
Shear V_{Rd} [kN]		11,5	11,5	13,7	13,7
Cracked concrete					
Tension N_{Rd} [kN]		7,4	8,2	9,0	9,3
Shear V_{Rd} [kN]		11,5	11,5	13,7	13,7

Recommended loads

Type	HUS4	H, HF, C		H, HF, C, A, AF	
Anchor size		8		10	
Nominal embedment depth h_{nom} [mm]		60	70	75	85
Uncracked concrete					
Tension N_{rec} [kN]		7,6	8,3	9,1	9,5
Shear V_{rec} [kN]		8,2	8,2	9,8	9,8
Cracked concrete					
Tension N_{rec} [kN]		5,3	5,9	6,4	6,7
Shear V_{rec} [kN]		8,2	8,2	9,8	9,8

Seismic loading based on Hilti technical data. Design according to EN 1992-4

All data in this section applies to:

- Correct setting (see setting instruction)
- For a single anchor
- Hammer drilled holes
- No edge distance and spacing influence (see setting detail tables with characteristic distances). Only one anchor can be used in the lower flute at a time with the min.spacing between anchors along the length of the flute to be at least $s = 3 h_{ef}$. This datasheet does not give information for the design of fasteners in a group.
- Minimum base material thickness (see setting detail table)
- Embedment depth, as specified in the table of this section
- Concrete from C30/37 without steel fibre. For higher compressive strengths, the tension resistance may be increased by $(f'_c / 30)^{0,5}$
- $\alpha_{gap} = 1,0$ (using Hilti filling set) and $\alpha_{gap} = 0,5$ (without using Hilti filling set) accordingly

For anchoring into the upper flute, either use table below conservatively or refer to ETA-20/0867. In this case the minimum required slab thickness h_{min} must be larger than the deck thickness $h_{min,deck}$.

Design resistance in case of seismic performance category C1

Type	HUS4	H, HF, C		H, HF, C, A, AF	
Anchor size		8		10	
Nominal embedment depth h_{nom} [mm]		60	70	75	85
with and without Hilti filling set					
Tension $N_{Rd,C}$ [kN]		7,4	8,2	9,0	9,3
with Hilti filling set ($\alpha_{gap} = 1,0$)					
Shear $V_{Rd,C}$ [kN]		11,8	11,8	13,8	13,8
without Hilti filling set ($\alpha_{gap} = 0,5$)					
Shear $V_{Rd,C}$ [kN]		5,8	5,8	6,9	6,9

Setting information

Setting details

Type	HUS4	H, HF, C		H, HF, C, A, AF	
Anchor size		8		10	
Nominal embedment depth	[mm]	60	70	75	85
Effective embedment depth	h_{ef} [mm]	47,6	56,1	59,5	68
Nominal diameter of drill bit	d_0 [mm]	8		10	
Clearance hole diameter	d_f [mm]	12		14	
Wrench size HUS4-H	SW1 [mm]	13		15	
Wrench size HUS4-A	SW1 [mm]	-		8	
Wrench size for nut on HUS4-A	SW2 [mm]	-		19	
Torx size for HUS4-C	TX [-]	45		50	
Countersunk head diameter	d_h [mm]	18		21	
Depth of drill hole for cleaned or uncleaned hole overhead	h_{1min} [mm]	70	80	85	95
Minimum base material thickness	h_{min} [mm]	125	125	130	140
Minimum concrete thickness over upper flute	$h_{min,deck}$ [mm]	70	70	70	70
Minimum distances					
Spacing	s_{min} [mm]	$3 h_{ef}$		$3,3 h_{ef}$	
Edge distance	c_{min} [mm]	$1,5 h_{ef}$		$1,65 h_{ef}$	
Minimum distance to edge of lower flute	$c_{min,deck}$ [mm]	45		47	
Characteristics distances					
Spacing for splitting failure	$s_{cr,sp}$ [mm]	$3 h_{ef}$		$3,3 h_{ef}$	
Edge distance for splitting	$c_{cr,sp}$ [mm]	$1,5 h_{ef}$		$1,65 h_{ef}$	
Spacing for concrete cone failure	$s_{cr,N}$ [mm]	$3 h_{ef}$			
Edge distance for concrete cone failure	$c_{cr,N}$ [mm]	$1,5 h_{ef}$			

For spacing (edge distance) smaller than characteristic spacing (characteristic edge distance) the design loads have to be reduced.

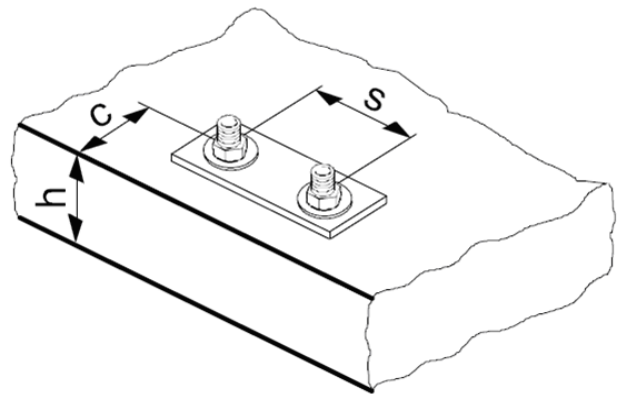

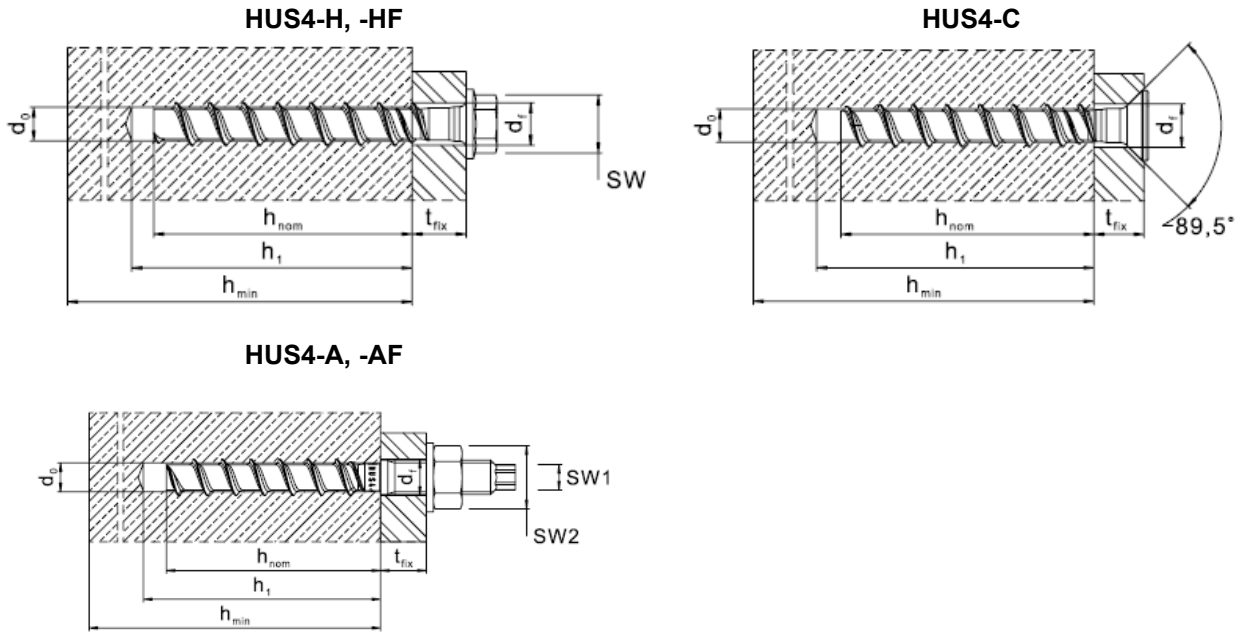



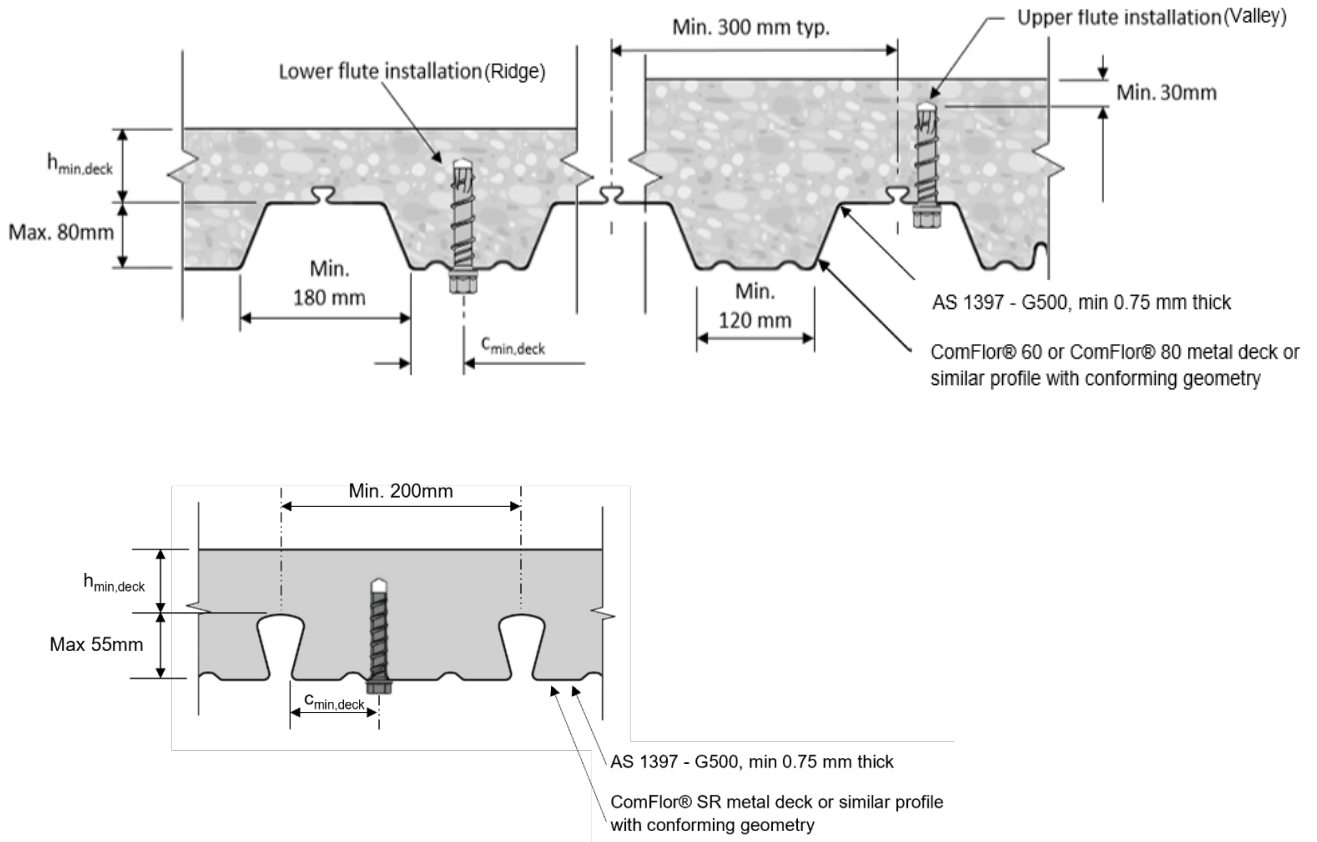

Installation position for HUS4 anchor in metal decks :





Drilling and Installation equipment

For detailed setting information on installation ,see instructions for use given with the product.

Rotary Hammers (Corded and Cordless)		TE 2 - TE 30
Other tools		Impact wrench- SIW (use recommended socket/driver bit)
		Hammer drill bit TE-CX, TE-C
		Blow out pump