

System No. CEJ 307 P (HI/BP 180-01)
PERIMETER FIRE BARRIER SYSTEM - ASTM E 2307

	CP 672 SPEED SPRAY	CP 672 FAST CURE	CFS-SP WB
F-RATING	3-HR.	3-HR.	3-HR.
T-RATING	1 3/4-HR.	1 1/4-HR.	1 3/4-HR.

L-RATING <1.0 SCFM/LF
 RATED FOR ± 11.25% HORIZONTAL MOVEMENT (SEE NOTE 1)
 RATED FOR ± 5% MOVEMENT

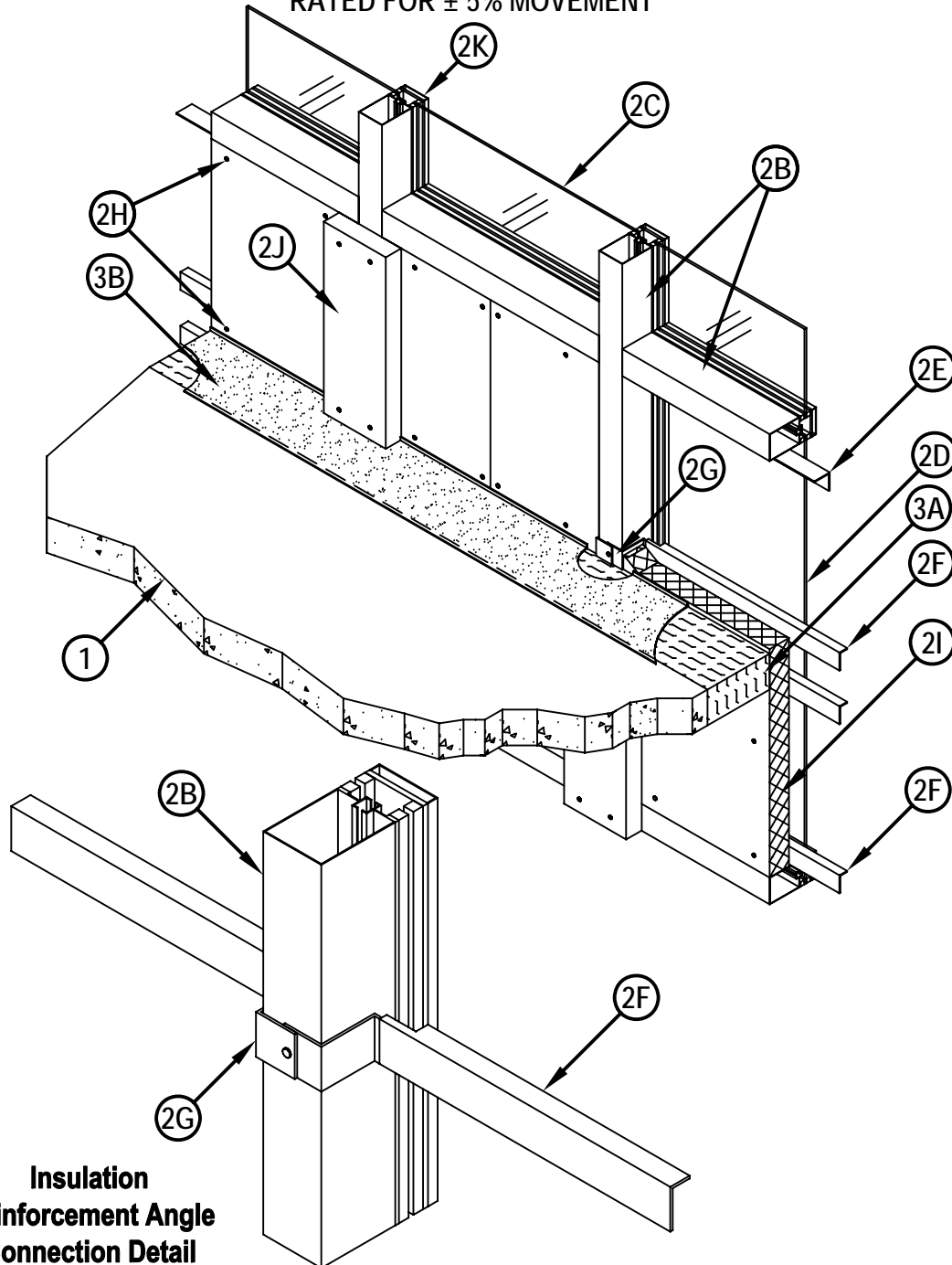

Hilti Firestop Systems

Reproduced by HILTI, Inc.
 Courtesy of Intertek Group
 November 06, 2010



System No. CEJ 307 P (HI/BP 180-01)
PERIMETER FIRE BARRIER SYSTEM - ASTM E 2307

	CP 672 SPEED SPRAY	CP 672 FAST CURE	CFS-SP WB
F-RATING	3-HR.	3-HR.	3-HR.
T-RATING	1 3/4-HR.	1 1/4-HR.	1 3/4-HR.

L-RATING <1.0 SCFM/LF
RATED FOR ± 11.25% HORIZONTAL MOVEMENT (SEE NOTE 1)
RATED FOR ± 5% MOVEMENT

1. CONCRETE FLOOR ASSEMBLY: Two-hour rated concrete floor assembly made from either lightweight or normal weight concrete with a density of 100-150 pcf, with a min. thickness of 4-1/2-in. at the joint face. Overall slab thickness may vary to accommodate various blockout depths (longitudinal recesses) formed in the concrete, to house the architectural cover plate. The blockout width may also vary without restriction.
2. CURTAIN WALL ASSEMBLY: The curtain wall assembly shall incorporate the following construction features:
 - A. Mounting Attachment: (Not shown) Attachment of the curtain wall framing to the structural framing shall be according to the curtain wall manufacturer's instructions to allow vertical shear movement only. When required, the mounting attachments to the floor slab shall be connected to the joint face of the floor slab, according to the curtain wall manufacturer's instructions. Max. distance between mounting attachments shall be 10 feet. One optional method is to use min. 8 in. wide by 3/4 in. thick extruded aluminum Halfen mullion mounting brackets with one nom. 2 in. high leg for support and attachment to the mullion and with one leg at least 6 in. longer than nominal joint width. Attach the mounting bracket to the top of the floor with two min 1/2 in. dia. steel masonry anchors in conjunction with washer plates supplied with the mounting brackets.
 - B. Aluminum Framing: Rectangular aluminum tubing mullions and transoms, sized according to the curtain wall system manufacturer's guidelines. Min. overall dimensions of the extruded framing sections are 0.100 in. thick aluminum with a min. 5-1/4 in. depth and a min. of 2-1/2 in. width. Mullion and Transom covers are added to the external side of the framing, giving the framing system a total depth of min. 6-3/4 in. Mullions are to be spaced a min. 56-1/2 in. o.c. and transoms are to be spaced a min. 49 in. o.c. For the spandrel region, the lower transom must be placed a min. of 21 in. below the concrete floor (as measured from the underside of the floor to the top side of the transom) and the upper transom must be placed a minimum of 21-1/2 in. above the floor (as measured from the top surface of the floor to the underside of the transom) while maintaining the minimum 46-1/2 in. spandrel panel height. One optional fastening method is to space the mullions as noted herein and secure the mullion mounting anchors (Item 2A) at each floor level in conjunction with extruded aluminum clips bolted to the sides of the mullions and designed to engage the vertical leg of the Halfen mullion mounting bracket in conjunction with an extruded aluminum hook/leveling connector.
 - C. Vision Glass Panels: Glass panels shall be sized and attached to curtain wall framing according to the curtain wall system manufacturer's guidelines. Use a min. 1/4 in. thick, clear heat-strengthened (HS) glass or tempered glass with a max. width and height less than the aluminum framing o.c. spacing, which allows the glass to be secured between the notched shoulder of the aluminum framing and pressure bar. Panels are secured with a thermal break (rubber extrusion), pressure bar (aluminum extrusion), min. 1/4-20 x 5/8 in. long screws, and a snap face (aluminum extrusion).
 - D. Spandrel Panels: Either glass or aluminum spandrel panels may be applied to the spandrel exterior:
 - If Glass Spandrel Panels: Glass panels shall be sized and installed to curtain wall framing according to the curtain wall system manufacturer's guidelines. Use a min. 1/4 in. thick clear, heat-strengthened (HS) glass or tempered glass with a max. width and height less than the aluminum framing o.c. spacing, which allows the glass to be secured between the notched shoulder of the aluminum framing and pressure bar. Panels are secured with a thermal break (rubber extrusion), pressure bar (aluminum extrusion), min. 1/4-20 x 5/8 in. long screws, and a snap face (aluminum extrusion).
 - Aluminum Spandrel Panels: Aluminum panels used in the spandrel shall be sized and attached to curtain wall framing according to the curtain wall system manufacturer's guidelines. Use a min. 1/8 in. sheet aluminum panel.
 - E. Insulation Retainer Angle: Secure a minimum 2 in. x 2 in. 20 GA galvanized steel angle to the underside of the top spandrel transom extending the full length of the transom between each vertical framing member. Position so that the curtain wall insulation (2I), when placed flush against the back surface of the angle, is flush with the internal surface of the vertical framing members. Secure the angle to the transom with min. 1 in. No. 10 self-tapping sheet metal screws spaced a maximum 12 in. o.c.



Hilti Firestop Systems

Reproduced by HILTI, Inc.
 Courtesy of Intertek Group
 November 06, 2010



System No. CEJ 307 P (HI/BP 180-01)
PERIMETER FIRE BARRIER SYSTEM - ASTM E 2307

	CP 672 SPEED SPRAY	CP 672 FAST CURE	CFS-SP WB
F-RATING	3-HR.	3-HR.	3-HR.
T-RATING	1 3/4-HR.	1 1/4-HR.	1 3/4-HR.

L-RATING <1.0 SCFM/LF
RATED FOR ± 11.25% HORIZONTAL MOVEMENT (SEE NOTE 1)
RATED FOR ± 5% MOVEMENT

- F. Insulation Reinforcement Angle: Place min. 1 in. x 2 in. 20 GA galvanized steel angle horizontally in the spandrel area to reinforce the curtain wall insulation (2I). The 2 in. leg is placed flush against the exterior surface of the curtain wall insulation and the 1 in. dimension is positioned at the top of the 2 in. leg, perpendicular to and outward from the insulation as illustrated. Place a minimum of 3 angles in each spandrel cavity between vertical framing members. Two angles are required to be spaced a max. 6 in. o.c. in the perimeter fire barrier region, with the top angle centered 1 in. above the floor. Outside of the perimeter fire barrier region, the spacing of these reinforcement angles is a max. 18 in o.c. On both ends of each angle, cut the 1 in. leg of the angle 2 in. from the end and fold down to form a slot that is slid onto the flange of the Z-Clip (2G).
- G. Z Clips: Position min. 2 in. wide Z-Clips having 2 in. long web and flange dimensions, constructed of min. 18 GA. galvanized steel, onto the mullion at the required elevation locations of the Insulation Reinforcement Angles (2F). Two Z-Clips are to be positioned at each location so that one clip extends on each side of the mullion, placed tightly against the mullion. The Z-clips are secured to the interior face of the mullion with a single 1 in. No. 10 self-tapping sheet metal screw placed at the center of the Z-Clips.
- H. Insulation Retaining Screws: In the field of the curtain wall insulation between framing covers (2J) attach curtain wall insulation (2I) to the insulation retainer angle (2E) and insulation reinforcement angle (2F) with min. 3 in. long No. 8 bugle head self-tapping screws fitted with min. 1 1/2 in. diameter steel clinch shields or self-locking washer clips. These are spaced a max. 12-3/4 in. o.c. and a max. 4 in. on each side of vertical seams. Where the framing covers (2J) overlap onto the curtain wall insulation (2I) secure framing covers (2J) and curtain wall insulation (2I) to the insulation retainer angle (2E) and insulation reinforcement angle (2F) with min. 5 in. long No. 10 bugle head self-tapping screws and min. 1-1/2 in. diameter steel clinch shields or self-locking washer clips in accordance with details in 2J.
- I. Curtain Wall Insulation: A nom. 2 in. thick, 8pcf density mineral wool batt insulation**, faced on one side with aluminum foil scrim (vapor retarder) which faces the room interior, is installed to fill all cavities of the spandrel region between the framing. The batt is to be fitted tightly to the framing, and is secured to the Insulation Retainer Angle (2E) and Insulation Reinforcement Angle (2F) with Insulation Retaining Screws and min. 1-1/2 in. diameter steel clinch shields or self-locking washer clips. (2H). A minimum 3 in. air space is created between the insulation and panel. All meeting edges of insulation are sealed with nom. 4-in. wide pressure sensitive aluminum foil faced tape centered over the junction so that approx. 2 in. of tape covers each edge of the adjacent insulation. The 36 in. wide batts shall be installed with a maximum of 1 vertically oriented seam in each spandrel cavity, between vertical framing members, spaced a min. 18 in. from any vertical framing member, and continuous vertically without horizontal seams.
- J. Framing Covers: Strips made of 2 in. thick by 8 in. wide, 8 pcf, mineral wool batt insulation, faced one side with aluminum foil scrim (vapor retarder) which faces the room interior, are centered over each vertical framing member and secured to the Insulation Retainer Angle (2E) and Insulation Reinforcement Angle (2F) with Insulation Retaining Screws spaced 1 in. from both edges of the framing cover. Framing covers do not pass through the perimeter joint treatment. They are butted to the top and bottom surfaces of the perimeter joint treatment.
- K. Panel Attachment: Secure panels with a thermal break (thermal-set rubber extrusion), pressure bar (aluminum extrusion), 1/4-20 x 5/8 in. long screws, and a snap face (aluminum extrusion). The spandrel panels shall be insulated according to 2I.



Hilti Firestop Systems

Reproduced by HILTI, Inc.
 Courtesy of Intertek Group
 November 06, 2010



System No. CEJ 307 P (HI/BP 180-01)
PERIMETER FIRE BARRIER SYSTEM - ASTM E 2307

	CP 672 SPEED SPRAY	CP 672 FAST CURE	CFS-SP WB
F-RATING	3-HR.	3-HR.	3-HR.
T-RATING	1 3/4-HR.	1 1/4-HR.	1 3/4-HR.

L-RATING <1.0 SCFM/LF
RATED FOR ± 11.25% HORIZONTAL MOVEMENT (SEE NOTE 1)
RATED FOR ± 5% MOVEMENT

3. PERIMETER JOINT PROTECTION: The perimeter joint (linear opening) shall not exceed an 8- in. nom. joint width (joint width at installation) and the perimeter joint treatment shall incorporate the following construction features:

A. Packing Material: Use a min. 4 in. thick, 4 pcf density, mineral wool** batt insulation installed with the fibers running parallel to the slab edge and curtain wall. The packing material shall be compressed 33% in the nominal joint width. Compress the batt insulation into the perimeter joint such that the top surface of the batt insulation is flush with the top surface of the concrete floor slab. Splices (butt joints) in the lengths of mineral wool batt insulation are to be tightly compressed together with min. compression of 0.25-in. per piece. Reference the Introduction to Fire Resistive Joint Systems Section of this Directory for more details on how to determine the cut width of the insulation to be installed in the nominal joint width, and how to determine the compressed percentage of a known insulation width installed in a known nominal joint width.

B. CERTIFIED MANUFACTURER: Hilti, Inc.

CERTIFIED PRODUCT: Joint Spray or Sealant

MODEL: CP 672 or CP 672 FC or CFS-SP WB Firestop Joint Spray

Fill, Void or Cavity Material: To be applied (sprayed, brushed, or trowled) to cover the exposed surface of the mineral wool installed in the perimeter joint. Apply a min. 1/8-in. wet film thickness and overlap the material a min. 1/2 in. onto the adjacent curtain wall assembly and concrete floor slab assembly. If the spraying process is stopped and the applied liquid cures to an elastomeric film before process is restarted, then overlap the edge of the cured material at least 1/8 in. with the spray. Reference Product Section of this Directory for more details about the Listed product.

Note 1 – Before testing, the spliced test specimen was cycled 500 times at 30 cpm according to ASTM E 1399 and ICBO ES AC 30 (Jan. 1997)

(* Product Certified by Intertek Testing Services bearing a WH Mark)

This Design Listing was created using the information outlined in the Introduction to the Fire-Resistant Joint Systems Section. Please refer to that Introduction to complement the Design Listing.



Hilti Firestop Systems

Reproduced by HILTI, Inc.
 Courtesy of Intertek Group
 November 06, 2010

