



European Technical Assessment

ETA-16/0143 du 12/07/2017

English translation prepared by CSTB - Original version in French language

General Part

Nom commercial
Trade name

Injection system Hilti HIT-RE 500 V3

Famille de produit
Product family

Cheville à scellement avec tige filetée, fers à béton, douille taraudée et cheville de traction Hilti HZA pour ancrage dans le béton fissuré.

Bonded fastener with threaded rods, rebar, internally sleeve and Hilti tension anchor HZA for use in concrete.

Titulaire
Manufacturer

Hilti Corporation
Feldkircherstrasse 100
FL-9494 Schaan
Principality of Liechtenstein

Usine de fabrication
Manufacturing plants

Hilti Plant

Cette évaluation contient:
This Assessment contains

477 pages incluant 44 pages d'annexes qui font partie intégrante de cette évaluation
477 pages including 44 pages of annexes which form an integral part of this assessment

Base de l'ETE
Basis of ETA

ETAG 001, Version April 2013, utilisée en tant que EAD
ETAG 001, Edition April 2013 used as EAD

Cette évaluation remplace:
This Assessment replaces

ETE-16/0143 du 28/07/2016
ETA-16/0143 dated 28/07/2016

Translations of this European Technical Assessment in other languages shall fully correspond to the original issued document and should be identified as such. Communication of this European Technical Assessment, including transmission by electronic means, shall be in full. However, partial reproduction may be made, with the written consent of the issuing Technical Assessment Body. Any partial reproduction has to be identified as such..

Specific Part

1 Technical description of the product

The Injection system Hilti HIT-RE 500 V3 is a bonded fastener consisting of a foil pack with injection mortar Hilti HIT-RE 500 V3 and a steel element.

- a threaded rod Hilti HIT-V, Hilti meter rod AM 8.8 or a commercial threaded rod with washer and hexagon nut in the range of M8 to M30
- a rebar in the range of $\phi 8$ to $\phi 32$
- a Hilti Tension Anchor HZA in the range of M12 to M27 or HZA-R in the range of M12 to M24.
- an internal threaded sleeve HIS-(R)N in the range M8 to M20

The steel element is placed into a drilled hole filled with injection mortar and is anchored via the bond between metal part, injection mortar and concrete.

The illustration and the description of the product are given in Annexes A.

2 Specification of the intended use

The performances given in Section 3 are only valid if the fastener is used in compliance with the specifications and conditions given in Annexes B.

The provisions made in this European technical assessment are based on an assumed working life of the fastener of 50 years. The indications given on the working life cannot be interpreted as a guarantee given by the producer, but are to be regarded only as a means for choosing the right products in relation to the expected economically reasonable working life of the works.

3 Performance of the product

3.1 Mechanical resistance and stability (BWR 1)

Essential characteristic	Performance
Characteristic resistance for static and quasi static loads, Displacements	See Annex C1 to C16
Characteristic resistance for seismic performance category C1, Displacements	See Annex C17 to C20
Characteristic resistance for seismic performance category C2, Displacements	See Annex C21

3.2 Safety in case of fire (BWR 2)

Essential characteristic	Performance
Reaction to fire	Anchorage satisfy requirements for Class A1
Resistance to fire	No performance assessed

3.3 Hygiene, health and the environment (BWR 3)

Regarding dangerous substances contained in this European technical approval, there may be requirements applicable to the products falling within its scope (e.g. transposed European legislation and national laws, regulations and administrative provisions). In order to meet the provisions of the Construction Products Directive, these requirements need also to be complied with, when and where they apply.

3.4 Safety in use (BWR 4)

For Basic requirement Safety in use the same criteria are valid as for Basic Requirement Mechanical resistance and stability.

3.5 Protection against noise (BWR 5)

Not relevant.

3.6 Energy economy and heat retention (BWR 6)

Not relevant.

3.7 Sustainable use of natural resources (BWR 7)

For the sustainable use of natural resources no performance was determined for this product.

3.8 General aspects relating to fitness for use

Durability and Serviceability are only ensured if the specifications of intended use according to Annex B1 are kept.

4 Assessment and verification of constancy of performance (AVCP)

According to the Decision 96/582/EC of the European Commission¹, as amended, the system of assessment and verification of constancy of performance (see Annex V to Regulation (EU) No 305/2011) given in the following table apply.

Product	Intended use	Level or class	System
Metal fasteners for use in concrete	For fixing and/or supporting to concrete, structural elements (which contributes to the stability of the works) or heavy units	—	1

5 Technical details necessary for the implementation of the AVCP system

Technical details necessary for the implementation of the Assessment and verification of constancy of performance (AVCP) system are laid down in the control plan deposited at Centre Scientifique et Technique du Bâtiment.

The manufacturer shall, on the basis of a contract, involve a notified body approved in the field of fasteners for issuing the certificate of conformity CE based on the control plan.

The original French version is signed by

Charles Baloche
Technical Director

¹ Official Journal of the European Communities L 254 of 08.10.1996

Installed condition

Figure A1:
 Threaded rod, HIT-V-..., AM...8.8 ...

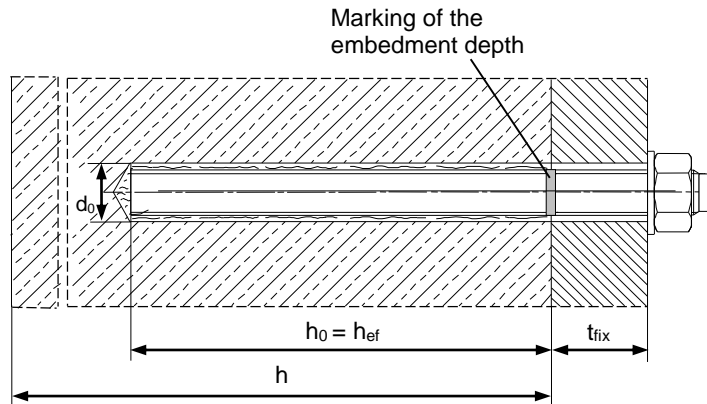

Figure A2:
 Threaded rod, HIT-V-..., AM...8.8, with Hilti Filling Set...

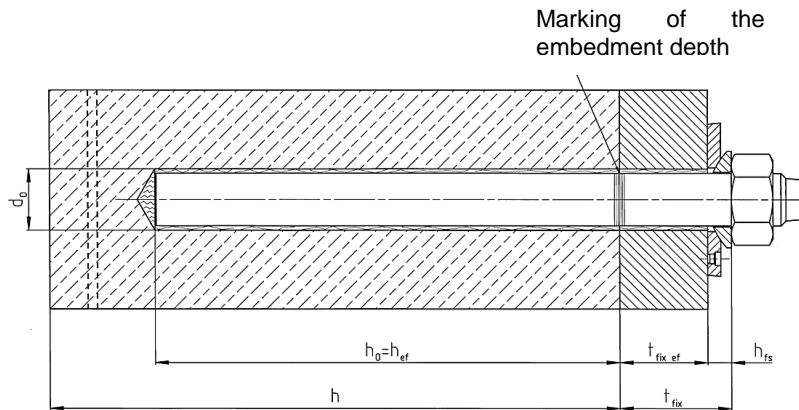
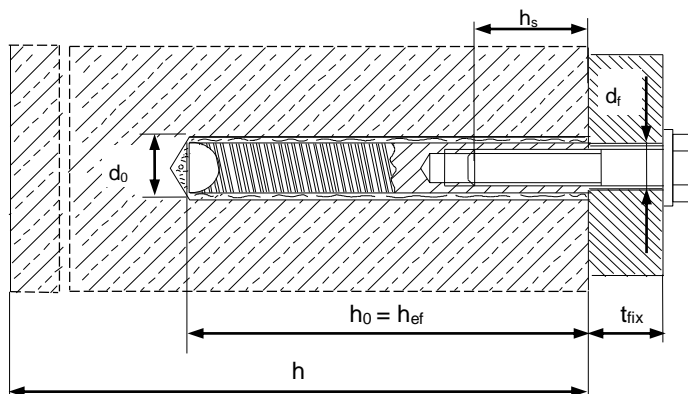

Figure A3:
 Internally threaded sleeve HIS-(R)N



Injection system Hilti HIT-RE 500 V3

Product
 Installed condition

Annex A1

Figure A4:
Reinforcing bar (rebar)

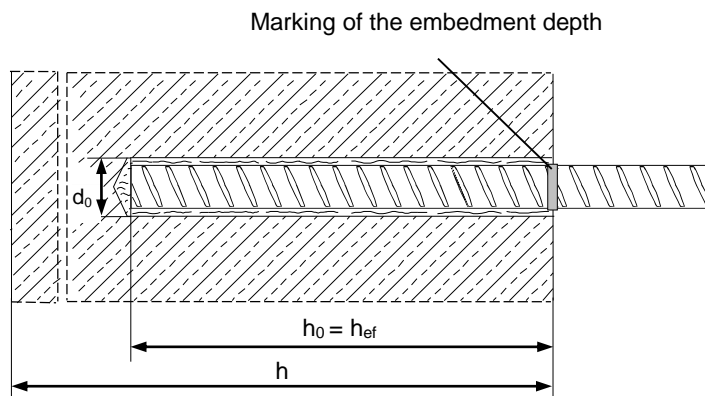

Injection system Hilti HIT-RE 500 V3

Product
Installed condition

Annex A2

Product description: Injection mortar and steel elements

Injection mortar Hilti HIT-RE 500 V3: epoxy resin system with aggregate

330 ml, 500 ml and 1400 ml

Marking:
 HILTI HIT
 Product name
 Production time and line
 Expiry date mm/yyyy



Product name: "Hilti HIT-RE 500 V3"

Static mixer Hilti HIT-RE-M



Steel elements

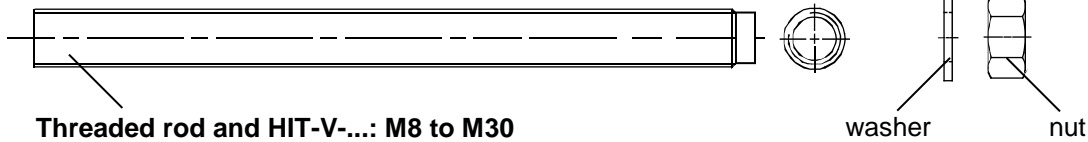

Threaded rod and HIT-V-...: M8 to M30

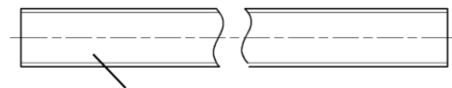

Hilti meter rod AM 8.8, electroplated zinc coated M8 to M30, 1m to 3m

Commercial standard threaded rod with:

- Materials and mechanical properties according to Table A1.
- Inspection certificate 3.1 according to EN 10204:2004. The document shall be stored.
- Marking of embedment depth.

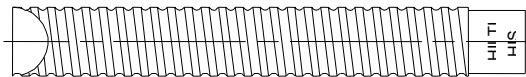

Internally threaded sleeve HIS-(R)N: M8 to M20

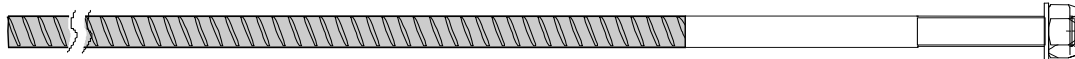

Hilti Tension Anchor HZA: M12 to M27 and HZA-R: M12 to M24



Reinforcing bar (rebar): ϕ 8 to ϕ 32

- Materials and mechanical properties according to Table A1.
- Dimensions according to Annex B6

Injection system Hilti HIT-RE 500 V3

Product
 Injection mortar / Static mixer / Steel elements

Annex A3

Hilti Filling Set to fill the annular gap between anchor and fixture

Sealing washer

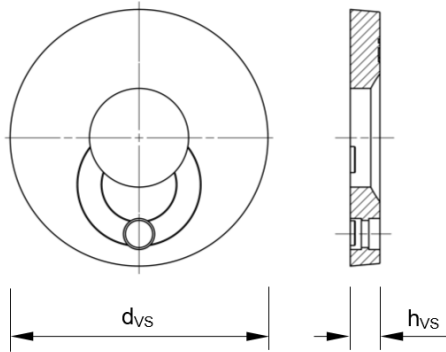

Spherical washer

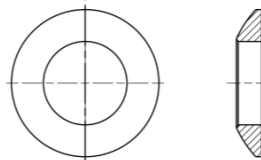

Filling Set			M16	M20	M24
Diameter of sealing washer	d_{vs}	[mm]	56	60	70
Thickness of sealing washer	h_{vs}	[mm]	6		

Injection system Hilti HIT-RE 500 V3

Product
 Injection mortar / Static mixer / Steel elements

Annex A4

Table A1: Materials

Designation	Material
Reinforcing bars (rebars)	
Rebar EN 1992-1-1:2004 and AC:2010, Annex C	Bars and de-coiled rods class B or C with f_{yk} and k according to NDP or NCL of EN 1992-1-1/NA:2013 $f_{uk} = f_{tk} = k \cdot f_{yk}$
Metal parts made of zinc coated steel	
Threaded rod, HIT-V-5.8 (F)	Strength class 5.8, $f_{uk} = 500 \text{ N/mm}^2$, $f_{yk} = 400 \text{ N/mm}^2$ Elongation at fracture ($l_0 = 5d$) > 8% ductile Electroplated zinc coated $\geq 5 \mu\text{m}$, (F) hot dip galvanized $\geq 45 \mu\text{m}$
Threaded rod, HIT-V-8.8 (F)	Strength class 8.8, $f_{uk} = 800 \text{ N/mm}^2$, $f_{yk} = 640 \text{ N/mm}^2$ Elongation at fracture ($l_0 = 5d$) > 12% ductile Electroplated zinc coated $\geq 5 \mu\text{m}$, V_{max}
Hilti Meter rod, AM 8.8 (HDG)	Strength class 8.8, $f_{uk} = 800 \text{ N/mm}^2$, $f_{yk} = 640 \text{ N/mm}^2$ Elongation at fracture ($l_0 = 5d$) > 12% ductile, Electroplated zinc coated $\geq 5 \mu\text{m}$, (HDG) hot dip galvanized $\geq 45 \mu\text{m}$
Hilti tension anchor HZA	Round steel with threaded part: electroplated zinc coated $\geq 5 \mu\text{m}$ Rebar: Bars class B according to NDP or NCL of EN 1992-1-1/NA:2013
Internally threaded sleeve HIS-N	Electroplated zinc coated $\geq 5 \mu\text{m}$
Washer	Electroplated zinc coated $\geq 5 \mu\text{m}$, hot dip galvanized $\geq 45 \mu\text{m}$
Nut	Strength class of nut adapted to strength class of threaded rod. Electroplated zinc coated $\geq 5 \mu\text{m}$, hot dip galvanized $\geq 45 \mu\text{m}$
Metal parts made of stainless steel	
Threaded rod, HIT-V-R	For $\leq \text{M}24$: strength class 70, $f_{uk} = 700 \text{ N/mm}^2$, $f_{yk} = 450 \text{ N/mm}^2$ For $> \text{M}24$: strength class 50, $f_{uk} = 500 \text{ N/mm}^2$, $f_{yk} = 210 \text{ N/mm}^2$ Elongation at fracture ($l_0 = 5d$) > 8% ductile Stainless steel 1.4401, 1.4404, 1.4578, 1.4571, 1.4439, 1.4362 EN 10088-1:2014
Hilti tension anchor HZA-R	Round steel with threaded part: Stainless steel 1.4404, 1.4362, 1.4571 EN 10088-1:2014 Rebar: Bars class B according to NDP or NCL of EN 1992-1-1/NA:2013
Internally threaded sleeve HIS-RN	Stainless steel 1.4401, 1.4571 EN 10088-1:2014
Washer	Stainless steel 1.4401, 1.4404, 1.4578, 1.4571, 1.4439, 1.4362 EN 10088-1:2014
Nut	Strength class of nut adapted to strength class of threaded rod. Stainless steel 1.4401, 1.4404, 1.4578, 1.4571, 1.4439, 1.4362 EN 10088-1:2014
Metal parts made of high corrosion resistant steel	
Threaded rod, HIT-V-HCR	For $\leq \text{M}20$: $f_{uk} = 800 \text{ N/mm}^2$, $f_{yk} = 640 \text{ N/mm}^2$ For $> \text{M}20$: $f_{uk} = 700 \text{ N/mm}^2$, $f_{yk} = 400 \text{ N/mm}^2$, Elongation at fracture ($l_0 = 5d$) > 8% ductile High corrosion resistant steel 1.4529, 1.4565 EN 10088-1:2014
Washer	High corrosion resistant steel 1.4529, 1.4565 EN 10088-1:2014
Nut	Strength class of nut adapted to strength class of threaded rod. High corrosion resistant steel 1.4529, 1.4565 EN 10088-1:2014

Injection system Hilti HIT-RE 500 V3

Product description
Materials

Annex A5

Table A2: Materials of Hilti seismic filling set

metal part of zinc coated steel	
Hilti Filling Set (F)	Filling washer: Electroplated zinc coated $\geq 5 \mu\text{m}$, (F) hot dip galvanized $\geq 45 \mu\text{m}$ Spherical washer: Electroplated zinc coated $\geq 5 \mu\text{m}$, (F) hot dip galvanized $\geq 45 \mu\text{m}$ Lock nut: Electroplated zinc coated $\geq 5 \mu\text{m}$, (F) hot dip galvanized $\geq 45 \mu\text{m}$

Injection system Hilti HIT-RE 500 V3

Product description
Materials

Annex A6

Specifications of intended use

Anchorage subject to:

- Static and quasi static loading.
- Seismic performance category C1
- Seismic performance category C2 (HIT-V , HIT-V-F, AM, AM-HDG grade 8.8 and commercial standard rod grade 8.8 electroplated zinc coated only, with hammer drilling and hammer drilling with Hilti hollow drill bit TE-CD, TE-YD).

Base material:

- Reinforced or unreinforced normal weight concrete according to EN 206:2013.
- Strength classes C20/25 to C50/60 according to EN 206:2013.
- Cracked and non-cracked concrete.
- Flooded holes for non cracked concrete only

Temperature in the base material:

- **At installation**
-5 °C to +40 °C
- **In-service**
Temperature range I: -40 °C to +40 °C
(max. long term temperature +24 °C and max. short term temperature +40 °C)
Temperature range II: -40 °C to +70 °C
(max. long term temperature +43 °C and max. short term temperature +70 °C)

Use conditions (Environmental conditions):

- Structures subject to dry internal conditions (zinc coated steel, stainless steel or high corrosion resistant steel).
- Structures subject to external atmospheric exposure (including industrial and marine environment) and to permanently damp internal conditions, if no particular aggressive conditions exist (stainless steel or high corrosion resistant steel).
- Structures subject to external atmospheric exposure and to permanently damp internal conditions, if other particular aggressive conditions exist (high corrosion resistant steel).
Note: Particular aggressive conditions are e.g. permanent, alternating immersion in seawater or the splash zone of seawater, chloride atmosphere of indoor swimming pools or atmosphere with extreme chemical pollution (e.g. in desulphurization plants or road tunnels where de-icing products are used).

Design:

- Anchorages are designed under the responsibility of an engineer experienced in anchorages and concrete work.
- Verifiable calculation notes and drawings are prepared taking account of the loads to be anchored. The position of the anchor is indicated on the design drawings (e. g. position of the anchor relative to reinforcement or to supports, etc.).
- Anchorages under static or quasi-static loading are designed in accordance with:
"EOTA Technical Report TR 029, 09/2010"
"CEN/TS 1992-4:2009"
- Anchorages under seismic actions (cracked concrete) are designed in accordance with:
"EOTA Technical Report TR 045, 02/2013"
Anchorages shall be positioned outside of critical regions (e.g. plastic hinges) of the concrete structure. Fastenings in stand-off installation or with a grout layer under seismic action are not covered in this European technical assessment (ETA).

Injection system Hilti HIT-RE 500 V3

Intended use
Specifications

Annex B1

Installation:

- Use category:
 - dry or wet concrete (not in flooded holes): for all drilling techniques
 - dry or wet concrete or installation in flooded holes: for hammer drilling only, for non-cracked concrete only
- Drilling technique:
 - hammer drilling,
 - hammer drilling with Hilti hollow drill bit TE-CD, TE-YD,
 - diamond coring,
 - diamond coring with roughening with Hilti roughening tool TE-YRT.
- Overhead installation is admissible.
- Anchor installation carried out by appropriately qualified personnel and under the supervision of the person responsible for technical matters of the site.

Injection system Hilti HIT-RE 500 V3

Intended use
Specifications

Annex B2

Table B1: Installation parameters of threaded rod and HIT-V and AM

Threaded rod, HIT-V-..., AM...8.8	M8	M10	M12	M16	M20	M24	M27	M30
Diameter of element $d^{1)} = d_{nom}^{2)}$ [mm]	8	10	12	16	20	24	27	30
Nominal diameter of drill bit d_0 [mm]	10	12	14	18	22	28	30	35
Threaded rod, HIT-V-...: Effective embedment depth and drill hole depth $h_{ef} = h_0$ [mm]	60 to 160	60 to 200	70 to 240	80 to 320	90 to 400	96 to 480	108 to 540	120 to 600
Maximum diameter of clearance hole in the fixture d_f ³⁾ [mm]	9	12	14	18	22	26	30	33
Thickness of Hilti filling set h_{fs} [mm]	-	-	-	11	13	15	-	-
Effective fixture thickness with Hilti filling set $t_{fix,eff}$ [mm]	$t_{fix,eff} = t_{fix} - h_{fs}$							
Minimum thickness of concrete member h_{min} [mm]	$h_{ef} + 30$ ≥ 100 mm			$h_{ef} + 2 \cdot d_0$				
Maximum torque moment T_{max} [Nm]	10	20	40	80	150	200	270	300
Minimum spacing s_{min} [mm]	40	50	60	75	90	115	120	140
Minimum edge distance c_{min} [mm]	40	45	45	50	55	60	75	80

1) Parameter for design according to "EOTA Technical Report TR 029".

2) Parameter for design according to "CEN/TS 1992-4:2009".

3) For larger clearance hole see "TR 029 section 1.1".

HIT-V-...

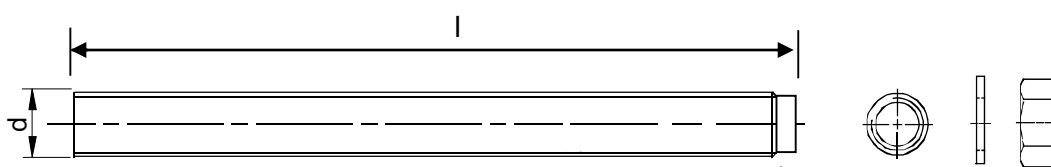

Marking:

- 5.8 - l = HIT-V-5.8 M...x l
- 5.8F - l = HIT-V-5.8F M...x l
- 8.8 - l = HIT-V-8.8 M...x l
- 8.8F - l = HIT-V-8.8F M...x l
- R - l = HIT-V-R M...x l
- HCR - l = HIT-V-HCR M...x l

AM...8.8

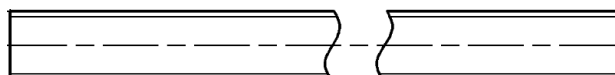

Injection system Hilti HIT-RE 500 V3

Intended use
 Installation parameters

Annex B3

Table B2: Installation parameters of internally threaded sleeve HIS-(R)N

Internally threaded sleeve HIS-(R)N			M8	M10	M12	M16	M20
Outer diameter of sleeve	$d^{1)} = d_{nom}^{2)}$	[mm]	12,5	16,5	20,5	25,4	27,6
Nominal diameter of drill bit	d_0	[mm]	14	18	22	28	32
Effective embedment depth and drill hole depth	$h_{ef} = h_0$	[mm]	90	110	125	170	205
Maximum diameter of clearance hole in the fixture ³⁾	d_f	[mm]	9	12	14	18	22
Minimum thickness of concrete member	h_{min}	[mm]	120	150	170	230	270
Maximum torque moment	T_{max}	[Nm]	10	20	40	80	150
Thread engagement length min-max	h_s	[mm]	8-20	10-25	12-30	16-40	20-50
Minimum spacing	s_{min}	[mm]	60	75	90	115	130
Minimum edge distance	c_{min}	[mm]	40	45	55	65	90

1) Parameter for design according to "EOTA Technical Report TR 029".

2) Parameter for design according to "CEN/TS 1992-4:2009".

3) For larger clearance hole see "TR 029 section 1.1".

Internally threaded sleeve HIS-(R)N...

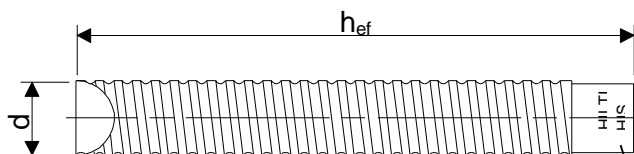

Marking:
 Identifying mark - HILTI and
 embossing "HIS-N" (for zinc coated steel)
 embossing "HIS-RN" (for stainless steel)

Injection system Hilti HIT-RE 500 V3

Intended use
 Installation parameters

Annex B4

Table B3: Installation parameters of Hilti tension anchor HZA-R

Hilti tension anchor HZA-R			M12	M16	M20	M24
Rebar diameter	ϕ	[mm]	12	16	20	25
Nominal embedment depth and drill hole depth	$h_{nom} = h_0$	[mm]	170 to 240	180 to 320	190 to 400	200 to 500
Effective embedment depth ($h_{ef} = h_{nom} - l_e$)	h_{ef}	[mm]	$h_{nom} - 100$			
Length of smooth shaft	l_e	[mm]	100			
Nominal diameter of drill bit	d_0	[mm]	16	20	25	32
Maximum diameter of clearance hole in the fixture ¹⁾	d_f	[mm]	14	18	22	26
Maximum torque moment	T_{max}	[Nm]	40	80	150	200
Minimum thickness of concrete member	h_{min}	[mm]	$h_{nom} + 2 \cdot d_0$			
Minimum spacing	s_{min}	[mm]	65	80	100	130
Minimum edge distance	c_{min}	[mm]	45	50	55	60

¹⁾ For larger clearance hole see "TR 029 section 1.1".

Hilti Tension Anchor HZA-R

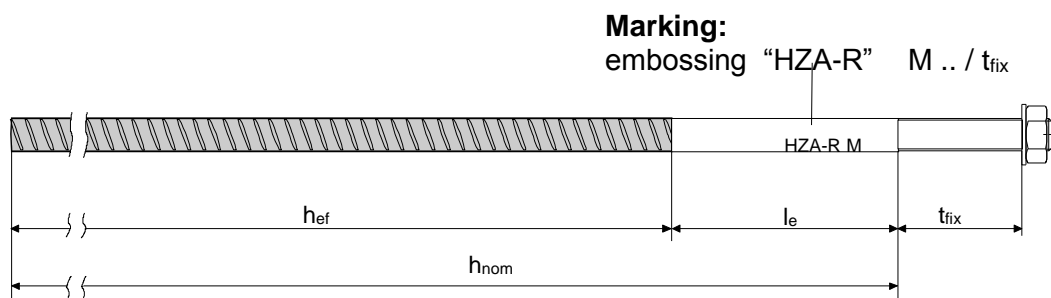

Injection system Hilti HIT-RE 500 V3

Intended use
 Installation parameters

Annex B5

Table B4: Installation parameters of Hilti tension anchor HZA

Hilti tension anchor HZA			M12	M16	M20	M24	M27
Rebar diameter	ϕ	[mm]	12	16	20	25	28
Nominal embedment depth and drill hole depth	$h_{nom} = h_0$	[mm]	90 to 240	100 to 320	110 to 400	120 to 500	140 to 560
Effective embedment depth ($h_{ef} = h_{nom} - l_e$)	h_{ef}	[mm]	$h_{nom} - 20$				
Length of smooth shaft	l_e	[mm]	20				
Nominal diameter of drill bit	d_0	[mm]	16	20	25	32	35
Maximum diameter of clearance hole in the fixture ¹⁾	d_f	[mm]	14	18	22	26	30
Maximum torque moment	T_{max}	[Nm]	40	80	150	200	270
Minimum thickness of concrete member	h_{min}	[mm]	$h_{nom} + 2 \cdot d_0$				
Minimum spacing	s_{min}	[mm]	65	80	100	130	140
Minimum edge distance	c_{min}	[mm]	45	50	55	60	75

¹⁾ For larger clearance hole see "TR 029 section 1.1".

Injection system Hilti HIT-RE 500 V3

Intended use
 Installation parameters

Annex B6

Table B5: Installation parameters of reinforcing bar (rebar)

Reinforcing bar (rebar)			ϕ 8	ϕ 10	ϕ 12	ϕ 14	ϕ 16	ϕ 20	ϕ 25	ϕ 28	ϕ 30	ϕ 32	
Diameter	ϕ	[mm]	8	10	12	14	16	20	25	28	30	32	
Effective embedment depth and drill hole depth	$h_{ef} = h_0$	[mm]	60 to 160	60 to 200	70 to 240	75 to 280	80 to 320	90 to 400	100 to 500	112 to 560	120 to 600	128 to 640	
Nominal diameter of drill bit	d_0	[mm]	10 ¹⁾ 12 ¹⁾	12 ¹⁾ 14 ¹⁾	14 ¹⁾	16 ¹⁾	18	20	25	30 ¹⁾ 32 ¹⁾	35	37	40
Minimum thickness of concrete member	h_{min}	[mm]	$h_{ef} + 30$ ≥ 100 mm			$h_{ef} + 2 \cdot d_0$							
Minimum spacing	s_{min}	[mm]	40	50	60	70	80	100	125	140	150	160	
Minimum edge distance	c_{min}	[mm]	40	45	45	50	50	65	70	75	80	80	

1) Each of the two given values can be used.

Reinforcing bar (rebar)

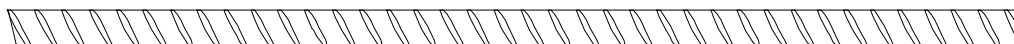

For Rebar bolt

- Minimum value of related rib area $f_{R,min}$ according to EN 1992-1-1:2004+AC:2010.
- Rib height of the bar h_{rib} shall be in the range $0,05 \cdot \phi \leq h_{rib} \leq 0,07 \cdot \phi$
 (ϕ : Nominal diameter of the bar; h_{rib} : Rib height of the bar).

Injection system Hilti HIT-RE 500 V3

Intended use
 Installation parameters

Annex B7

Table B6: Minimum curing time¹⁾

Temperature in the base material T	Maximum working time t _{work}	Minimum curing time t _{cure} ¹⁾
-5 °C to -1 °C	≥ 2 hours	168 hours
0 °C to 4 °C	≥ 2 hours	48 hours
5 °C to 9 °C	2 hours	24 hours
10 °C to 14 °C	1,5 hours	16 hours
15 °C to 19 °C	1 hours	12 hours
20 °C to 24 °C	30 min	7 hours
25 °C to 29 °C	20 min	6 hours
30 °C to 34 °C	15 min	5 hours
35 °C to 39 °C	12 min	4,5 hours
40 °C	10 min	4 hours

¹⁾ The curing time data are valid for dry base material only. In wet base material the curing times must be doubled.











Injection system Hilti HIT-RE 500 V3

Intended use

Maximum working time and minimum curing time



Annex B8

Table B7: Parameters of cleaning and setting tools

Elements				Drill and clean				Installation	
Threaded rod, HIT-V-... AM...8.8	HIS-(R)N	Rebar	HZA(-R)	Hammer drilling	Hollow drill bit TE-CD, TE-YD	Diamond coring	Roughening tool TE-YRT	Brush	Piston plug
									
Size	Name	Size	Size	d ₀ [mm]	d ₀ [mm]	d ₀ [mm]	d ₀ [mm]	HIT-RB	HIT-SZ
M8	-	φ 8	-	10	-	10	-	10	-
M10	-	φ 8, φ 10	-	12	-	12	-	12	12
M12	M8	φ 10, φ 12	-	14	14 ¹⁾	14	-	14	14
-	-	φ 12	M12	16	16	16	-	16	16
M16	M10	φ 14	-	18	18	18	18	18	18
-	-	φ 16	M16	20	20	20	20	20	20
M20	M12	-	-	22	22	22	22	22	22
-	-	φ 20	M20	25	25	25	25	25	25
M24	M16	-	-	28	28	28	28	28	28
M27	-	-	-	30	-	30	30	30	30
-	M20	φ 25	M24	32	32	32	32	32	32
M30	-	φ 28	M27	35	35	35	35	35	35
-	-	φ 30	-	37	-	37	-	37	37
-	-	φ 32	-	40	-	-	-	40	40
				-	-	42	-	42	42

¹⁾ To be used in combination with Hilti vacuum cleaner with suction volume ≥ 61 l/s (VC 20/40 –Y in corded mode only).

Cleaning alternatives



<p>Compressed Air Cleaning (CAC): air nozzle with an orifice opening of minimum 3,5 mm in diameter.</p>	
<p>Automatic Cleaning (AC): Cleaning is performed during drilling with Hilti TE-CD and TE-YD drilling system including vacuum cleaner.</p>	

Injection system Hilti HIT-RE 500 V3

Intended use
 Cleaning and setting tools

Annex B9

Table B8: Parameters for use of the Hilti roughening tool TE-YRT

Associated components				Installation	
Diamond coring		Roughening tool TE-YRT	Wear gauge RTG...	Minimum roughening time $t_{roughen}$	
					
d_o [mm]		d_o [mm]	size	$t_{roughen} [sec] = h_{ef} [mm] / 10$	
nominal	measured				
18	17,9 to 18,2	18	18		
20	19,9 to 20,2	20	20		
22	21,9 to 22,2	22	22		
25	24,9 to 25,2	25	25		
28	27,9 to 28,2	28	28		
30	29,9 to 30,2	30	30		
32	31,9 to 32,2	32	32		
35	34,9 to 35,2	35	35		
				h_{ef} [mm]	$t_{roughen}$ [sec]
				0 to 100	10
				101 to 200	20
				201 to 300	30
				301 to 400	40
				401 to 500	50
				501 to 600	60

Hilti roughening tool TE-YRT and wear gauge RTG

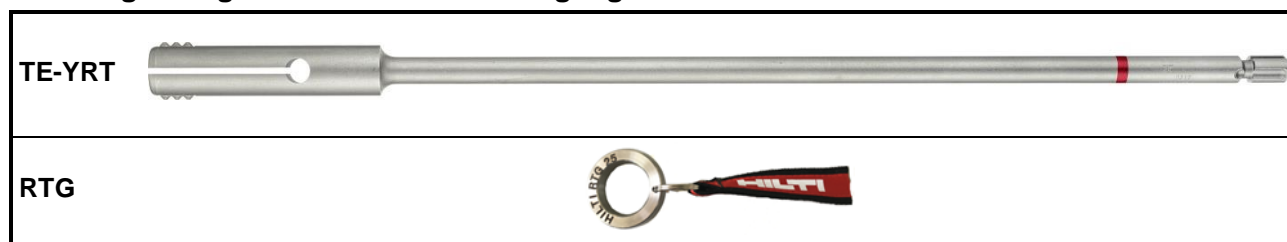

Injection system Hilti HIT-RE 500 V3

Intended use

Parameters for use of the Hilti Roughening tool TE-YRT

Annex B10

Installation instruction

Hole drilling

a) Hammer drilling: For dry or wet concrete and installation in flooded holes (no sea water).

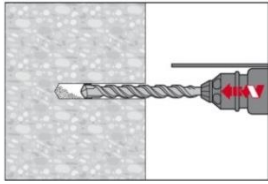

Drill hole to the required embedment depth with a hammer drill set in rotation-hammer mode using an appropriately sized carbide drill bit.

b) Hammer drilling with Hilti hollow drill bit TE-CD, TE-YD: For dry and wet concrete only.

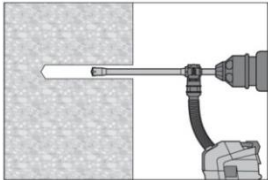

Drill hole to the required embedment depth with an appropriately sized Hilti TE-CD or TE-YD hollow drill bit attached to Hilti vacuum cleaner VC 20/40 (-Y) (suction volume ≥ 57 l/s) with automatic cleaning of the filter activated. This drilling system removes the dust and cleans the bore hole during drilling when used in accordance with the user's manual. When using TE-CD 14 refer to Table B7. After drilling is completed, proceed to the "injection preparation" step in the installation instruction.

c) Diamond coring: For dry and wet concrete only.

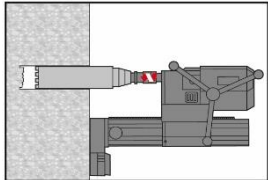

Diamond coring is permissible when suitable diamond core drilling machines and the corresponding core bits are used.

d) Diamond coring with roughening with Hilti roughening tool TE-YRT: For dry and wet concrete only.

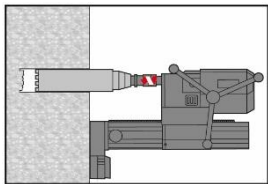

Diamond coring is permissible when suitable diamond core drilling machines and the corresponding core bits are used.

For the use in combination with Hilti roughening tool TE-YRT see parameters in Table B8.

Before roughening water needs to be removed from the borehole. Check usability of the roughening tool with the wear gauge RTG.

Roughen the borehole over the whole length to the required h_{ef} .

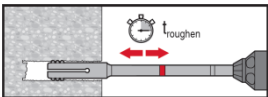

Injection system Hilti HIT-RE 500 V3

Intended use
 Installation instructions

Annex B11

Drill hole cleaning:

Just before setting an anchor, the drill hole must be free of dust and debris.
Inadequate hole cleaning = poor load values.

Compressed Air Cleaning (CAC): For all drill hole diameters d_0 and all drill hole depths h_0 .

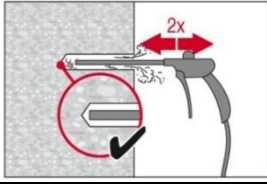

Blow 2 times from the back of the hole (if needed with nozzle extension) over the whole length with oil-free compressed air (min. 6 bar at 6 m³/h) until return air stream is free of noticeable dust.
For drill hole diameters ≥ 32 mm the compressor has to supply a minimum air flow of 140 m³/h.

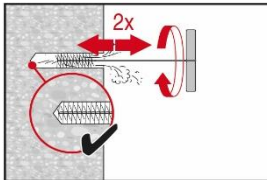

Brush 2 times with the specified brush (see Table B7) by inserting the steel brush Hilti HIT-RB to the back of the hole (if needed with extension) in a twisting motion and removing it.
The brush must produce natural resistance as it enters the drill hole (brush $\varnothing \geq$ drill hole \varnothing) - if not the brush is too small and must be replaced with the proper brush diameter.

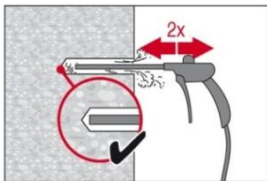

Blow again with compressed air 2 times until return air stream is free of noticeable dust.

Injection system Hilti HIT-RE 500 V3

Intended use
Installation instructions

Annex B12

Cleaning of hammer drilled flooded holes and diamond cored holes:

For all drill hole diameters d_0 and all drill hole depths h_0 .

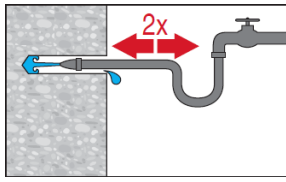

Flush 2 times by inserting a water hose (water-line pressure) to the back of the hole until water runs clear.

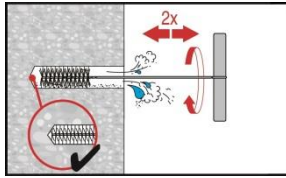

Brush 2 times with the specified brush (see Table B7) by inserting the steel brush Hilti HIT-RB to the back of the hole (if needed with extension) in a twisting motion and removing it.
 The brush must produce natural resistance as it enters the drill hole (brush $\varnothing \geq$ drill hole \varnothing) - if not the brush is too small and must be replaced with the proper brush diameter.

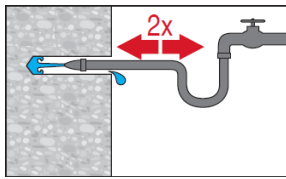

Flush 2 times by inserting a water hose (water-line pressure) to the back of the hole until water runs clear.

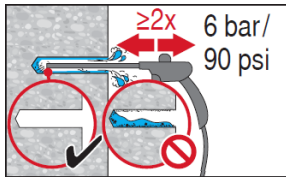

Blow 2 times from the back of the hole (if needed with nozzle extension) over the whole length with oil-free compressed air (min. 6 bar at 6 m³/h) until return air stream is free of noticeable dust and water.
 For drill hole diameters ≥ 32 mm the compressor has to supply a minimum air flow of 140 m³/h.

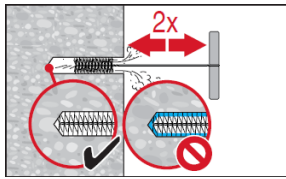

Brush 2 times with the specified brush size (brush $\varnothing \geq$ drill hole \varnothing , see Table B7) by inserting the steel brush Hilti HIT-RB to the back of the hole (if needed with extension) in a twisting motion and removing it.
 The brush must produce natural resistance as it enters the drill hole – if not the brush is too small and must be replaced with the proper brush diameter.

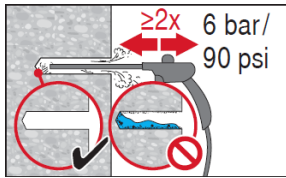

Blow again with compressed air 2 times until return air stream is free of noticeable dust and water.

Injection system Hilti HIT-RE 500 V3

Intended use
 Installation instructions

Annex B13

Cleaning of diamond cored holes with roughening with Hilti roughening tool TE-YRT:

For all drill hole diameters d_0 and all drill hole depths h_0 .

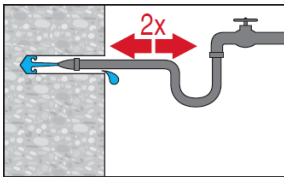

Flush 2 times by inserting a water hose (water-line pressure) to the back of the hole until water runs clear.

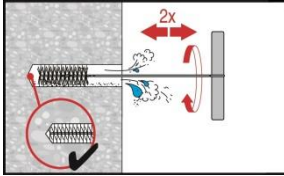

Brush 2 times with the specified brush (see Table B7) by inserting the steel brush Hilti HIT-RB to the back of the hole (if needed with extension) in a twisting motion and removing it.

The brush must produce natural resistance as it enters the drill hole (brush $\varnothing \geq$ drill hole \varnothing) - if not the brush is too small and must be replaced with the proper brush diameter.

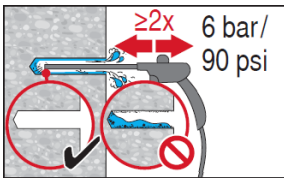

Blow 2 times from the back of the hole (if needed with nozzle extension) over the whole length with oil-free compressed air (min. 6 bar at 6 m³/h) until return air stream is free of noticeable dust and water.

For drill hole diameters ≥ 32 mm the compressor has to supply a minimum air flow of 140 m³/h.

Injection system Hilti HIT-RE 500 V3

Intended use
Installation instructions

Annex B14

Injection preparation

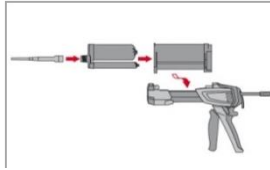

Tightly attach Hilti mixing nozzle HIT-RE-M to foil pack manifold. Do not modify the mixing nozzle.
 Observe the instruction for use of the dispenser.
 Check foil pack holder for proper function. Insert foil pack into foil pack holder and put holder into dispenser.

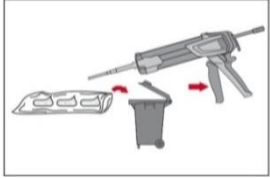

The foil pack opens automatically as dispensing is initiated. Depending on the size of the foil pack an initial amount of adhesive has to be discarded.
 Discarded quantities are: 3 strokes for 330 ml foil pack,
 4 strokes for 500 ml foil pack,
 65 ml for 1400 ml foil pack.

Inject adhesive from the back of the drill hole without forming air voids.

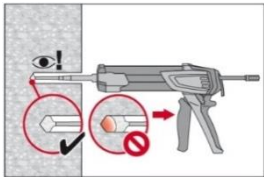

Inject the adhesive starting at the back of the hole, slowly withdrawing the mixer with each trigger pull.
 Fill approximately 2/3 of the drill hole to ensure that the annular gap between the anchor and the concrete is completely filled with adhesive along the embedment length.

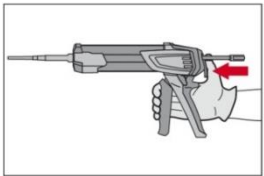

After injection is completed, depressurize the dispenser by pressing the release trigger. This will prevent further adhesive discharge from the mixer.

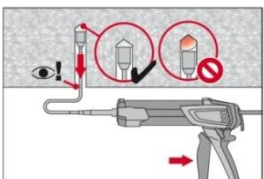

Overhead installation and/or installation with embedment depth $h_{ef} > 250$ mm. For overhead installation the injection is only possible with the aid of extensions and piston plugs. Assemble HIT-RE-M mixer, extension(s) and appropriately sized piston plug (see Table B7). Insert piston plug to back of the hole and inject adhesive. During injection the piston plug will be naturally extruded out of the drill hole by the adhesive pressure.

Setting the element

Just before setting an anchor, the drill hole must be free of dust and debris.

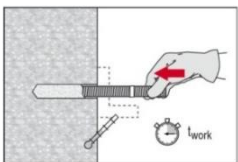

Before use, verify that the element is dry and free of oil and other contaminants. Mark and set element to the required embedment depth before working time t_{work} has elapsed. The working time t_{work} is given in Table B6.

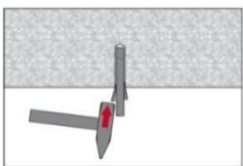

For overhead installation use piston plugs and fix embedded parts with e.g. wedges.

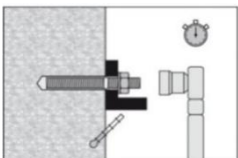

Loading the anchor: After required curing time t_{cure} (see Table B6) the anchor can be loaded. The applied installation torque shall not exceed the values T_{max} given in Tables B1, B2, B3 and B4.

Injection system Hilti HIT-RE 500 V3

Intended use
 Installation instructions

Annex B15

Installation of Filling Set

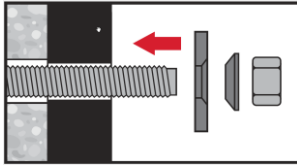

Use Hilti filling set with standard nut. Observe the correct orientation of filling washer and spherical washer.

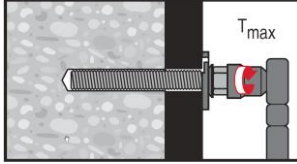

The applied installation torque shall not exceed the values T_{max} given in **Erreur ! Source du renvoi introuvable.**1 to Table B5.

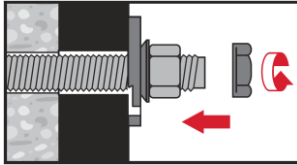

Optional:
Installation of lock nut. Tighten with a $\frac{1}{4}$ to $\frac{1}{2}$ turn. (Not for size M24.)

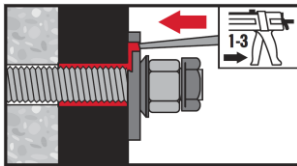

Fill the annular gap between the anchor rod and fixture with 1-3 strokes of Hilti injection mortar HIT-RE 500 V3.
Follow the installation instructions supplied with the HIT-RE 500 V3 foil pack.

Injection system Hilti HIT-RE 500 V3

Intended use
Installation instructions

Annex B16

Table C1: Characteristic resistance for threaded rods under tension load in concrete

Threaded rod, HIT-V-..., AM...8.8				M8	M10	M12	M16	M20	M24	M27	M30
Installation safety factor											
Hammer drilling	$\gamma_2^{(1)} = \gamma_{inst}^{(2)}$	[-]	1,0								
Hammer drilling with Hilti hollow drill bit TE-CD or TE-YD	$\gamma_2^{(1)} = \gamma_{inst}^{(2)}$	[-]	-	1,0							
Diamond coring	$\gamma_2^{(1)} = \gamma_{inst}^{(2)}$	[-]	1,2				1,4				
Diamond coring with roughening with Hilti roughening tool TE-YRT	$\gamma_2^{(1)} = \gamma_{inst}^{(2)}$	[-]	-				1,0				
Hammer drilling in flooded holes	$\gamma_2^{(1)} = \gamma_{inst}^{(2)}$	[-]	1,4								
Steel failure threaded rods											
Characteristic resistance	$N_{Rk,s}$	[kN]	$A_s \cdot f_{uk}$								
Partial safety factor Grade 5.8	$\gamma_{Ms,N}$	[-]	1,5								
Partial safety factor Grade 8.8	$\gamma_{Ms,N}$	[-]	1,5								
Partial safety factor HIT-V-R	$\gamma_{Ms,N}$	[-]	1,87						2,86		
Partial safety factor HIT-V-HCR	$\gamma_{Ms,N}$	[-]	1,5						2,1		
Combined pullout and concrete cone failure											
Characteristic bond resistance in non-cracked concrete C20/25 in hammer drilled holes and hammer drilled holes with Hilti hollow drill bit TE-CD or TE-YD and diamond cored holes with roughening with Hilti roughening tool TE-YRT											
Temperature range I: 40°C / 24°C	$\tau_{Rk,ucr}$	[N/mm ²]	18	18	17	16	15	15	14	13	
Temperature range II: 70°C / 43°C	$\tau_{Rk,ucr}$	[N/mm ²]	14	13	13	12	12	11	10	10	
Characteristic bond resistance in non-cracked concrete C20/25 in diamond cored holes.											
Temperature range I: 40°C / 24°C	$\tau_{Rk,ucr}$	[N/mm ²]	12	12	12	12	12	11	11	11	
Temperature range II: 70°C / 43°C	$\tau_{Rk,ucr}$	[N/mm ²]	9,5	9	9	9	9	8,5	8,5	8,5	
Characteristic bond resistance in non-cracked concrete C20/25 in hammer drilled holes and installation in water-filled holes											
Temperature range I: 40°C / 24°C	$\tau_{Rk,ucr}$	[N/mm ²]	15	15	15	14	13	12	12	11	
Temperature range II: 70°C / 43°C	$\tau_{Rk,ucr}$	[N/mm ²]	12	11	11	10	10	9,5	9	8,5	
Factor acc. to section 6.2.2.3 of CEN/TS 1992-4:2009 part 5	$k_8^{(2)}$	[-]	10,1								
Characteristic bond resistance in cracked concrete C20/25 in hammer drilled holes and hammer drilled holes with Hilti hollow drill bit TE-CD or TE-YD and diamond cored holes with roughening with Hilti roughening tool TE-YRT											
Temperature range I: 40°C / 24°C	$\tau_{Rk,cr}$	[N/mm ²]	6,5	7,5	8	8	8	8	8	8	
Temperature range II: 70°C / 43°C	$\tau_{Rk,cr}$	[N/mm ²]	5,5	6	6	6	6	6	6	6	
Factor acc. to section 6.2.2.3 of CEN/TS 1992-4:2009 part 5	$k_8^{(2)}$	[-]	7,2								

Injection system Hilti HIT-RE 500 V3

Performances

Characteristic resistance under tension load in concrete
Design according to "EOTA Technical Report TR 029, 09/2010" or "CEN/TS 1992-4:2009"

Annex C1

Table C1: continued

Threaded rod, HIT-V-..., AM...8.8			M8	M10	M12	M16	M20	M24	M27	M30
Combined pullout and concrete cone failure (continued)										
Increasing factors for τ_{Rk} in concrete	in hammer drilled holes and hammer drilled holes with Hilti hollow drill bit TE-CD or TE-YD and diamond cored holes	ψ_{fc}	C30/37	1,04						
			C40/50	1,07						
			C50/60	1,09						
	in diamond cored holes with roughening with Hilti roughening tool TE-YRT	ψ_{fc}	C50/60	-	1,0					
Concrete cone failure										
Factor acc. to section 6.2.3 of CEN/TS 1992-4:2009 part 5	$k_{ucr}^{2)}$	[-]	10,1							
	$k_{cr}^{2)}$	[-]	7,2							
Edge distance	$c_{cr,N}$	[mm]	$1,5 \cdot h_{ef}$							
Spacing	$s_{cr,N}$	[mm]	$3,0 \cdot h_{ef}$							
Splitting failure										
Factor acc. to section 6.2.3 of CEN/TS 1992-4:2009 part 5	$k_{ucr}^{2)}$	[-]	10,1							
	$k_{cr}^{2)}$	[-]	7,2							
Edge distance $c_{cr,sp}$ [mm] for	$h / h_{ef} \geq 2,0$		$1,0 \cdot h_{ef}$							
	$2,0 > h / h_{ef} > 1,3$		$4,6 \cdot h_{ef} - 1,8 \cdot h$							
	$h / h_{ef} \leq 1,3$		$2,26 \cdot h_{ef}$							
Spacing	$s_{cr,sp}$	[mm]	$2 \cdot c_{cr,sp}$							

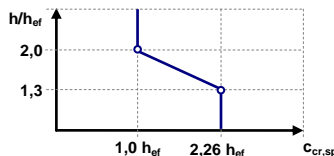

1) Parameter for design according to EOTA Technical Report TR 029.
 2) Parameter for design according to CEN/TS 1992-4:2009.

Injection system Hilti HIT-RE 500 V3

Performances

Characteristic resistance under tension load in concrete
 Design according to "EOTA Technical Report TR 029, 09/2010" or "CEN/TS 1992-4:2009"

Annex C2

Table C2: Characteristic resistance for internally threaded sleeve HIS-(R)N under tension load in concrete

HIS-(R)N			M8	M10	M12	M16	M20
Outer diameter of sleeve	$d^{(1)} = d_{nom}^{(2)}$	[mm]	12,5	16,5	20,5	25,4	27,6
Installation safety factor							
Hammer drilling	$\gamma_2^{(1)} = \gamma_{inst}^{(2)}$	[-]	1,0				
Hammer drilling with Hilti hollow drill bit TE-CD or TE-YD	$\gamma_2^{(1)} = \gamma_{inst}^{(2)}$	[-]	1,0				
Diamond coring	$\gamma_2^{(1)} = \gamma_{inst}^{(2)}$	[-]	1,2	1,4			
Diamond coring with roughening with Hilti roughening tool TE-YRT	$\gamma_2^{(1)} = \gamma_{inst}^{(2)}$	[-]	-	1,0			
Hammer drilling in flooded holes	$\gamma_2^{(1)} = \gamma_{inst}^{(2)}$	[-]	1,4				
Steel failure							
Characteristic resistance HIS-N with with screw grade 8.8	$N_{Rk,s}$	[kN]	25	46	67	125	116
Partial safety factor	$\gamma_{Ms,N}$	[-]	1,5				
Characteristic resistance HIS-RN with with screw grade 70	$N_{Rk,s}$	[kN]	26	41	59	110	166
Partial safety factor	$\gamma_{Ms,N}$	[-]	1,87				2,4
Combined pullout and concrete cone failure³⁾							
Characteristic bond resistance in non-cracked concrete C20/25 in hammer drilled holes and hammer drilled holes with Hilti hollow drill bit TE-CD or TE-YD and diamond cored holes with roughening with Hilti roughening tool TE-YRT							
Temperature range I: 40°C / 24°C	$\tau_{Rk,ucr}$	[N/mm ²]	13	13	13	13	13
Temperature range II: 70°C / 43°C	$\tau_{Rk,ucr}$	[N/mm ²]	10	10	10	10	10
Characteristic bond resistance in non-cracked concrete C20/25 in diamond cored holes.							
Temperature range I: 40°C / 24°C	$\tau_{Rk,ucr}$	[N/mm ²]	8,5	8,5	9	9	9,5
Temperature range II: 70°C / 43°C	$\tau_{Rk,ucr}$	[N/mm ²]	6,5	6,5	6,5	7	7
Characteristic bond resistance in non-cracked concrete C20/25 in hammer drilled holes and installation in water-filled holes							
Temperature range I: 40°C / 24°C	$\tau_{Rk,ucr}$	[N/mm ²]	11	11	11	11	11
Temperature range II: 70°C / 43°C	$\tau_{Rk,ucr}$	[N/mm ²]	8,5	8,5	8,5	8,5	8,5
Factor acc. to section 6.2.2.3 of CEN/TS 1992-4:2009 part 5	$k_s^{(3)}$	[-]	10,1				

Injection system Hilti HIT-RE 500 V3

Performances

Characteristic resistance under tension load in concrete
Design according to "EOTA Technical Report TR 029, 09/2010" or "CEN/TS 1992-4:2009"

Annex C3

Table C2: continued

HIS-(R)N			M8	M10	M12	M16	M20
Combined pullout and concrete cone failure³⁾ (continued)							
Characteristic bond resistance in cracked concrete C20/25 in hammer drilled holes and hammer drilled holes with Hilti hollow drill bit TE-CD or TE-YD and diamond cored holes with roughening with Hilti roughening tool TE-YRT							
Temperature range I:	40°C / 24°C	$\tau_{Rk,cr}$	[N/mm ²]	8,5	8,5	8,5	8,5
Temperature range II:	70°C / 43°C	$\tau_{Rk,cr}$	[N/mm ²]	7	7	7	7
Factor acc. to section 6.2.2.3 of CEN/TS 1992-4:2009 part 5		$k_g^{2)}$	[-]	7,2			
Increasing factors for τ_{Rk} in concrete	in hammer drilled holes and hammer drilled holes with Hilti hollow drill bit TE-CD or TE-YD and diamond cored holes	ψ_c	C30/37	1,04			
			C40/50	1,07			
			C50/60	1,09			
	in diamond cored holes with roughening with Hilti roughening tool TE-YRT	ψ_c	C50/60	-	1,0		
Concrete cone failure							
Factor acc. to section 6.2.3 of CEN/TS 1992-4:2009 part 5		$k_{ucr}^{2)}$	[-]	10,1			
		$k_{cr}^{2)}$	[-]	7,2			
Edge distance		$c_{cr,N}$	[mm]	1,5 · h _{ef}			
Spacing		$s_{cr,N}$	[mm]	3,0 · h _{ef}			
Splitting failure							
Factor acc. to section 6.2.3 of CEN/TS 1992-4:2009 part 5		$k_{ucr}^{2)}$	[-]	10,1			
		$k_{cr}^{2)}$	[-]	7,2			
Edge distance $c_{cr,sp}$ [mm] for		$h / h_{ef} \geq 2,0$		1,0 · h _{ef}			
		$2,0 > h / h_{ef} > 1,3$		4,6 · h _{ef} - 1,8 · h			
		$h / h_{ef} \leq 1,3$		2,26 · h _{ef}			
Spacing		$s_{cr,sp}$	[mm]	2 · c _{cr,sp}			

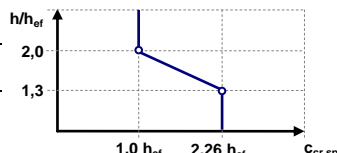

1) Parameter for design according to EOTA Technical Report TR 029.

2) Parameter for design according to CEN/TS 1992-4:2009.

3) For design according to CEN/TS 1992-1:2009, the characteristic tension load values bond resistance may be calculated from the characteristic bond resistance for combined pull-out and concrete cone failure according to:

$$N_{Rk} = \tau_{Rk} \cdot (h_{ef} \cdot d_1 \cdot \pi).$$

Injection system Hilti HIT-RE 500 V3

Performances

Characteristic resistance under tension load in concrete
Design according to "EOTA Technical Report TR 029, 09/2010" or "CEN/TS 1992-4:2009"

Annex C4

Table C3: Characteristic resistance for Hilti tension anchor HZA / HZA-R under tension load in concrete

HZA / HZA-R			M12	M16	M20	M24	M27
Rebar diameter	ϕ	[mm]	12	16	20	25	28
Installation safety factor							
Hammer drilling	$\gamma_2^{(1)} = \gamma_{inst}^{(2)}$	[-]	1,0				
Hammer drilling with Hilti hollow drill bit TE-CD or TE-YD	$\gamma_2^{(1)} = \gamma_{inst}^{(2)}$	[-]	1,0				
Diamond coring	$\gamma_2^{(1)} = \gamma_{inst}^{(2)}$	[-]	1,2	1,4			
Diamond coring with roughening with Hilti roughening tool TE-YRT	$\gamma_2^{(1)} = \gamma_{inst}^{(2)}$	[-]	-	1,0			
Hammer drilling in flooded holes	$\gamma_2^{(1)} = \gamma_{inst}^{(2)}$	[-]	1,4				
Steel failure							
Characteristic resistance HZA	$N_{Rk,s}$	[kN]	46	86	135	194	252
Characteristic resistance HZA-R	$N_{Rk,s}$	[kN]	62	111	173	249	-
Partial safety factor	$\gamma_{Ms,N}$	[-]	1,4				
Combined pullout and concrete cone failure							
Characteristic bond resistance in non-cracked concrete C20/25 in hammer drilled holes and hammer drilled holes with Hilti hollow drill bit TE-CD or TE-YD and diamond cored holes with roughening with Hilti roughening tool TE-YRT							
Temperature range I: 40°C / 24°C	$\tau_{Rk,ucr}$	[N/mm ²]	14	14	14	13	13
Temperature range II: 70°C / 43°C	$\tau_{Rk,ucr}$	[N/mm ²]	11	10	10	10	9,5
Characteristic bond resistance in non-cracked concrete C20/25 in diamond cored holes.							
Temperature range I: 40°C / 24°C	$\tau_{Rk,ucr}$	[N/mm ²]	9	9	9	9	9,5
Temperature range II: 70°C / 43°C	$\tau_{Rk,ucr}$	[N/mm ²]	6,5	6,5	7	7	7
Characteristic bond resistance in non-cracked concrete C20/25 in hammer drilled holes and installation in water-filled holes							
Temperature range I: 40°C / 24°C	$\tau_{Rk,ucr}$	[N/mm ²]	12	12	12	11	11
Temperature range II: 70°C / 43°C	$\tau_{Rk,ucr}$	[N/mm ²]	9	9	8,5	8,5	8,5
Factor acc. to section 6.2.2.3 of CEN/TS 1992-4:2009 part 5	$k_8^{(3)}$	[-]	10,1				

Injection system Hilti HIT-RE 500 V3

Performances

Characteristic resistance under tension load in concrete
 Design according to "EOTA Technical Report TR 029, 09/2010" or "CEN/TS 1992-4:2009"

Annex C5

Table C3: continued

HZA / HZA-R				M12	M16	M20	M24	M27
Rebar diameter	ϕ	[mm]		12	16	20	25	28
Combined pullout and concrete cone failure (continued)								
Characteristic bond resistance in cracked concrete C20/25 in hammer drilled holes and hammer drilled holes with Hilti hollow drill bit TE-CD or TE-YD and diamond cored holes with roughening with Hilti roughening tool TE-YRT								
Temperature range I:	40°C / 24°C	$\tau_{Rk,cr}$	[N/mm ²]	9,5	9,5	10	10	11
Temperature range II:	70°C / 43°C	$\tau_{Rk,cr}$	[N/mm ²]	8	8	8	8	8
Factor acc. to section 6.2.2.3 of CEN/TS 1992-4:2009 part 5		$k_8^{2)}$	[-]	7,2				
Increasing factors for τ_{Rk} in concrete	in hammer drilled holes and hammer drilled holes with Hilti hollow drill bit TE-CD or TE-YD and diamond cored holes	ψ_c	C30/37	1,04				
			C40/50	1,07				
			C50/60	1,09				
	in diamond cored holes with roughening with Hilti roughening tool TE-YRT	ψ_c	C50/60	1,0				
Embedment depth for calculation of $N_{Rk,p}^0$ acc. eq. 5.2a (TR 029 §5.2.2.4)	HZA	h_{ef}	[mm]	$h_{nom} - 20$				
	HZA-R	h_{ef}	[mm]	$h_{nom} - 100$				
Concrete cone failure								
Embedment depth for calculation of $N_{Rk,c}^0$ acc. eq. 5.3a (TR 029 §5.2.2.4)		h_{ef}	[mm]	h_{nom}				
Factor acc. to section 6.2.3 of CEN/TS 1992-4:2009 part 5		$k_{ucr}^{2)}$	[-]	10,1				
		$k_{cr}^{2)}$	[-]	7,2				
Edge distance		$c_{cr,N}$	[mm]	$1,5 \cdot h_{ef}$				
Spacing		$s_{cr,N}$	[mm]	$3,0 \cdot h_{ef}$				
Splitting failure								
Factor acc. to section 6.2.3 of CEN/TS 1992-4:2009 part 5		$k_{ucr}^{2)}$	[-]	10,1				
		$k_{cr}^{2)}$	[-]	7,2				
Edge distance $c_{cr,sp}$ [mm] for	$h / h_{ef} \geq 2,0$			$1,0 \cdot h_{ef}$				
	$2,0 > h / h_{ef} > 1,3$			$4,6 \cdot h_{ef} - 1,8 \cdot h$				
	$h / h_{ef} \leq 1,3$			$2,26 \cdot h_{ef}$				
Spacing		$s_{cr,sp}$	[mm]	$2 \cdot c_{cr,sp}$				

1) Parameter for design according to EOTA Technical Report TR 029.

2) Parameter for design according to CEN/TS 1992-4:2009.

Injection system Hilti HIT-RE 500 V3

Performances

Characteristic resistance under shear load in concrete
 Design according to "EOTA Technical Report TR 029, 09/2010" or "CEN/TS 1992-4:2009"

Annex C6

Table C4: Characteristic resistance for reinforcing bars (rebars) under tension load in concrete

Reinforcing bar (rebar)	ϕ 8	ϕ 10	ϕ 12	ϕ 14	ϕ 16	ϕ 20	ϕ 25	ϕ 28	ϕ 30	ϕ 32	
Installation safety factor											
Hammer drilling $\gamma_2^{(1)} = \gamma_{inst}^{(2)}$ [-]	1,0										
Hammer drilling with Hilti hollow drill bit TE-CD or TE-YD $\gamma_2^{(1)} = \gamma_{inst}^{(2)}$ [-]	-	1,0							-		
Diamond coring $\gamma_2^{(1)} = \gamma_{inst}^{(2)}$ [-]	1,2				1,4						
Diamond coring with roughening with Hilti roughening tool TE-YRT $\gamma_2^{(1)} = \gamma_{inst}^{(2)}$ [-]	-	1,0							-		
Hammer drilling in flooded holes $\gamma_2^{(1)} = \gamma_{inst}^{(2)}$ [-]	1,4										
Steel failure rebars											
Characteristic resistance for rebar B500B acc. to DIN 488:2009-08 ¹⁾ $N_{Rk,s}$ [kN]	28	43	62	85	111	173	270	339	388	442	
Partial safety factor for rebar B500B acc. to DIN 488:2009-08 ¹⁾ $\gamma_{Ms,N}$ [-]	1,4										
Combined pullout and concrete cone failure											
Characteristic bond resistance in non-cracked concrete C20/25 in hammer drilled holes and hammer drilled holes with Hilti hollow drill bit TE-CD or TE-YD and diamond cored holes with roughening with Hilti roughening tool TE-YRT											
Temperature range I: 40°C / 24°C $\tau_{Rk,ucr}$ [N/mm ²]	9,5	14	14	14	14	14	13	13	13	13	
Temperature range II: 70°C / 43°C $\tau_{Rk,ucr}$ [N/mm ²]	7	11	11	11	10	10	10	9,5	9,5	9,5	
Characteristic bond resistance in non-cracked concrete C20/25 in diamond cored holes.											
Temperature range I: 40°C / 24°C $\tau_{Rk,ucr}$ [N/mm ²]	9	9	9	9	9	9	9	9,5	9,5	9,5	
Temperature range II: 70°C / 43°C $\tau_{Rk,ucr}$ [N/mm ²]	6,5	6,5	6,5	6,5	6,5	7	7	7	7	7	
Characteristic bond resistance in non-cracked concrete C20/25 in hammer drilled holes and installation in water-filled holes											
Temperature range I: 40°C / 24°C $\tau_{Rk,ucr}$ [N/mm ²]	8	12	12	12	12	12	11	11	11	11	
Temperature range II: 70°C / 43°C $\tau_{Rk,ucr}$ [N/mm ²]	5,5	9	9	9	9	8,5	8,5	8,5	8	8	
Factor acc. to section 6.2.2.3 of CEN/TS 1992-4:2009 part 5 k_8 [-]	10,1										

¹⁾ Values need to be calculated acc. EOTA Technical Report TR 029, Eq. 3.3a and Eq. 5.1, if rebars do not fulfil the requirements acc. DIN 488.

Injection system Hilti HIT-RE 500 V3

Performances

Characteristic resistance under shear load in concrete
Design according to "EOTA Technical Report TR 029, 09/2010" or "CEN/TS 1992-4:2009"

Annex C7

Table C4: continued

Reinforcing bar (rebar)				φ 8	φ 10	φ 12	φ 14	φ 16	φ 20	φ 25	φ 28	φ 30	φ 32
Combined pullout and concrete cone failure (continued)													
Characteristic bond resistance in cracked concrete C20/25 in hammer drilled holes and hammer drilled holes with Hilti hollow drill bit TE-CD or TE-YD and diamond cored holes with roughening with Hilti roughening tool TE-YRT													
Temperature range I:	40°C / 24°C	$\tau_{Rk,cr}$	[N/mm ²]	4,5	8,5	9,5	9,5	9,5	10	10	11	11	11
Temperature range II:	70°C / 43°C	$\tau_{Rk,cr}$	[N/mm ²]	4	7	8	8	8	8	8	8	8	8
Factor acc. to section 6.2.2.3 of CEN/TS 1992-4:2009 part 5		$k_8^{2)}$	[-]	7,2									
Increasing factors for τ_{Rk} in concrete	in hammer drilled holes and hammer drilled holes with Hilti hollow drill bit TE-CD or TE-YD	ψ_c	C30/37	1,04									
			C40/50	1,07									
	and diamond cored holes		C50/60	1,09									
	in diamond cored holes with roughening with Hilti roughening tool TE-YRT	ψ_c	C50/60	1,0									
Concrete cone failure													
Combined pullout and concrete cone failure													
Factor acc. to section 6.2.3 of CEN/TS 1992-4:2009 part 5		$k_{ucr}^{2)}$	[-]	10,1									
		$k_{cr}^{2)}$	[-]	7,2									
Edge distance		$c_{cr,N}$	[mm]	$1,5 \cdot h_{ef}$									
Spacing		$s_{cr,N}$	[mm]	$3,0 \cdot h_{ef}$									
Splitting failure													
Factor acc. to section 6.2.3 of CEN/TS 1992-4:2009 part 5		$k_{ucr}^{2)}$	[-]	10,1									
		$k_{cr}^{2)}$	[-]	7,2									
Edge distance $c_{cr,sp}$ [mm] for	$h / h_{ef} \geq 2,0$			$1,0 \cdot h_{ef}$									
	$2,0 > h / h_{ef} > 1,3$			$4,6 \cdot h_{ef} - 1,8 \cdot h$									
	$h / h_{ef} \leq 1,3$			$2,26 \cdot h_{ef}$									
Spacing	$s_{cr,sp}$		[mm]	$2 \cdot c_{cr,sp}$									

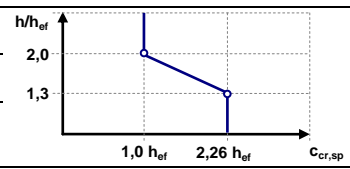

1) Parameter for design according to EOTA Technical Report TR 029.
 2) Parameter for design according to CEN/TS 1992-4:2009.

Injection system Hilti HIT-RE 500 V3

Performances

Characteristic resistance under tension load in concrete
 Design according to "EOTA Technical Report TR 029, 09/2010" or "CEN/TS 1992-4:2009"

Annex C8

Table C5: Characteristic resistance for threaded rods under shear load in concrete

Threaded rod, HIT-V-..., AM...8.8	M8	M10	M12	M16	M20	M24	M27	M30
Partial safety factor								
Steel failure grade 5.8 $\gamma_{Ms,v}$ [-]	1,25							
Steel failure grade 8.8 $\gamma_{Ms,v}$ [-]	1,25							
Steel failure HIT-V-R $\gamma_{Ms,v}$ [-]	1,56						2,38	
Steel failure HIT-V-HCR $\gamma_{Ms,v}$ [-]	1,25					1,75		
Steel failure without lever arm for threaded rod, HIT-V								
Factor according to section 6.3.2.1 of CEN/TS 1992-4 :2009 part 5 $k_2^{2)}$ [-]	1,0							
Characteristic resistance $V_{Rk,s}$ [kN]	$0,5 \cdot A_s \cdot f_{uk}$							
Steel failure with lever arm for threaded rod, HIT-V								
Characteristic resistance $M_{Rk,s}^0$ [Nm]	$1,2 \cdot W_{el} \cdot f_{uk}$							
Concrete pry-out failure								
Factor in equation (5.7) of TR 029 or acc. to equation (27) of CEN/TS 1992-4 :2009 part 5 $k^1) = k_3^{2)}$ [-]	2,0							
Concrete edge failure								
See section 5.2.3.4 of TR 029 « Design of bonded anchors »								

1) Parameter for design according to "EOTA Technical Report TR 029".

2) Parameter for design according to CEN/TS 1992-4:2009.

Injection system Hilti HIT-RE 500 V3

Performances

Characteristic resistance under shear load in concrete
 Design according to "EOTA Technical Report TR 029, 09/2010" or "CEN/TS 1992-4:2009"

Annex C9

Table C6: Characteristic resistance for for internally threaded sleeve HIS-(R)N under shear load in concrete

HIS-(R)N		M8	M10	M12	M16	M20
Steel failure without lever arm						
Factor according to section 6.3.2.1 of CEN/TS 1992-4 :2009 part 5	$k_2^{2)}$ [-]	1,0				
Characteristic resistance HIS-N screw class 8.8	$V_{Rk,s}$ [kN]	13	23	34	63	58
Partial safety factor	$\gamma_{Ms,v}$ [-]	1,25				
Characteristic resistance HIS-RN screw class 70	$V_{Rk,s}$ [kN]	13	20	30	55	83
Partial safety factor	$\gamma_{Ms,v}$ [-]	1,56				2,0
Steel failure with lever arm						
Characteristic resistance HIS-N screw class 8.8	$M^0_{Rk,s}$ [Nm]	30	60	105	266	519
Partial safety factor	$\gamma_{Ms,v}$ [-]	1,25				
Characteristic resistance HIS-RN screw class 70	$M^0_{Rk,s}$ [Nm]	26	52	92	233	454
Partial safety factor	$\gamma_{Ms,v}$ [-]	1,56				
Concrete pryout failure						
Factor in equation (5.7) of TR 029 or acc. to equation (27) of CEN/TS 1992-4 :2009 part 5	$k^1) = k_3^{2)}$ [-]	2,0				
Concrete edge failure see TR 029						
See section 5.2.3.4 of TR 029 « Design of bonded anchors »						

1) Parameter for design according to "EOTA Technical Report TR 029".

2) Parameter for design according to CEN/TS 1992-4:2009.

Injection system Hilti HIT-RE 500 V3

Performances

Characteristic resistance under shear load in concrete
 Design according to "EOTA Technical Report TR 029, 09/2010" or "CEN/TS 1992-4:2009"

Annex C10

Table C7: Characteristic resistance for Hilti tension anchor HZA / HZA-R under shear load in concrete

HZA / HZA-R			M12	M16	M20	M24	M27
Rebar diameter	ϕ	[mm]	12	16	20	25	28
Steel failure without lever arm							
Factor according to section 6.3.2.1 of CEN/TS 1992-4 :2009 part 5	$k_2^{2)}$	[-]	1,0				
Characteristic resistance HZA	$V_{Rk,s}$	[kN]	23	43	67	97	126
Characteristic resistance HZA-R	$V_{Rk,s}$	[kN]	31	55	86	124	-
Partial safety factor	$\gamma_{Ms,v}$	[-]	1,5				
Steel failure with lever arm							
Characteristic resistance HZA	$M_{Rk,s}^0$	[Nm]	72	183	357	617	915
Characteristic resistance HZA-R	$M_{Rk,s}^0$	[Nm]	97	234	458	790	-
Partial safety factor	$\gamma_{Ms,v}$	[-]	1,5				
Concrete pryout failure							
Factor in equation (5.7) of TR 029 or acc. to equation (27) of CEN/TS 1992-4 :2009 part 5	$k^1) = k_3^{2)}$	[-]	2.0				
Concrete edge failure see TR 029							
See section 5.2.3.4 of TR 029 « Design of bonded anchors »							

¹⁾ Parameter for design according to "EOTA Technical Report TR 029".

²⁾ Parameter for design according to CEN/TS 1992-4:2009.

Injection system Hilti HIT-RE 500 V3

Performances

Characteristic resistance under shear load in concrete
 Design according to "EOTA Technical Report TR 029, 09/2010" or "CEN/TS 1992-4:2009"

Annex C11

Table C8: Characteristic resistance for reinforcing bars (rebars) under shear load in concrete

Reinforcing bar (rebar)	ϕ 8	ϕ 10	ϕ 12	ϕ 14	ϕ 16	ϕ 20	ϕ 25	ϕ 28	ϕ 30	ϕ 32	
Steel failure without lever arm											
Factor according to section 6.3.2.1 of CEN/TS 1992-4 :2009 part 5 $k_2^{2)}$	[-] 1,0										
Characteristic resistance for rebar B500B acc. to DIN 488:2009-08 $V_{Rk,s}^{3)}$	[kN]	14	22	31	42	55	86	135	169	194	221
Partial safety factor for rebar B500B acc. to DIN 488:2009-08 $\gamma_{Ms,v}^{3)}$	[-] 1,5										
Steel failure with lever arm											
Characteristic resistance $M_{Rk,s}^0$	[Nm]	33	65	112	178	265	518	1012	1422	1749	2123
Partial safety factor $\gamma_{Ms,v}$	[-] 1,5										
Concrete pryout failure											
Factor in equation (5.7) of TR 029 or acc. to equation (27) of CEN/TS 1992-4 :2009 part 5 $k^{1)} = k_3^{2)}$	[-] 2,0										
Concrete edge failure see TR 029											
See section 5.2.3.4 of TR 029 « Design of bonded anchors »											

1) Parameter for design according to "EOTA Technical Report TR 029".

2) Parameter for design according to CEN/TS 1992-4:2009.

3) Values need to be calculated acc. EOTA Technical Report TR 029, Eq. 3.3b, Eq. 3.3c, Eq. 5.5 and Eq. 5.6b, if rebars do not fulfil the requirements acc. DIN 488.

Injection system Hilti HIT-RE 500 V3

Performances

Characteristic resistance under shear load in concrete
 Design according to "EOTA Technical Report TR 029, 09/2010" or "CEN/TS 1992-4:2009"

Annex C12

Table C9: Displacements for threaded rod under tension load

Threaded rod, HIT-V-..., AM...8.8		M8	M10	M12	M16	M20	M24	M27	M30	
Non-cracked concrete										
Temperature range I: 40°C / 24°C										
Displacement	δ_{N0}	[mm/(N/mm ²)]	0,04	0,05	0,05	0,06	0,06	0,07	0,08	0,08
Displacement	$\delta_{N\infty}$	[mm/(N/mm ²)]	0,10	0,11	0,12	0,13	0,15	0,17	0,18	0,19
Temperature range II: 70°C / 43°C										
Displacement	δ_{N0}	[mm/(N/mm ²)]	0,05	0,05	0,06	0,07	0,07	0,08	0,09	0,10
Displacement	$\delta_{N\infty}$	[mm/(N/mm ²)]	0,12	0,13	0,14	0,16	0,18	0,20	0,21	0,23
Cracked concrete										
Temperature range I: 40°C / 24°C										
Displacement	δ_{N0}	[mm/(N/mm ²)]	0,02	0,03	0,05	0,08	0,10	0,13	0,15	0,18
Displacement	$\delta_{N\infty}$	[mm/(N/mm ²)]	0,12	0,19	0,14	0,19	0,16	0,16	0,15	0,18
Temperature range II: 70°C / 43°C										
Displacement	δ_{N0}	[mm/(N/mm ²)]	0,02	0,04	0,06	0,09	0,12	0,16	0,18	0,21
Displacement	$\delta_{N\infty}$	[mm/(N/mm ²)]	0,15	0,23	0,17	0,23	0,19	0,19	0,18	0,21

Table C10: Displacements for threaded rod under shear load

Threaded rod, HIT-V-..., AM...8.8		M8	M10	M12	M16	M20	M24	M27	M30	
Displacement	δ_{V0}	[mm/kN]	0,06	0,06	0,05	0,04	0,04	0,03	0,03	0,03
Displacement	$\delta_{V\infty}$	[mm/kN]	0,09	0,08	0,08	0,06	0,06	0,05	0,05	0,05

Injection system Hilti HIT-RE 500 V3

Performances
 Displacements

Annex C13

Table C11: Displacements for HIS-N under tension load

HIS-(R)N			M8	M10	M12	M16	M20
Non-cracked concrete							
Temperature range I: 40°C / 24°C							
Displacement	δ_{N0}	[mm/(N/mm ²)]	0,05	0,06	0,06	0,07	0,08
Displacement	$\delta_{N\infty}$	[mm/(N/mm ²)]	0,12	0,13	0,15	0,17	0,18
Temperature range II: 70°C / 43°C							
Displacement	δ_{N0}	[mm/(N/mm ²)]	0,06	0,07	0,07	0,08	0,09
Displacement	$\delta_{N\infty}$	[mm/(N/mm ²)]	0,14	0,16	0,18	0,20	0,21
Cracked concrete							
Temperature range I: 40°C / 24°C							
Displacement	δ_{N0}	[mm/(N/mm ²)]	0,05	0,08	0,10	0,13	0,15
Displacement	$\delta_{N\infty}$	[mm/(N/mm ²)]	0,14	0,19	0,16	0,16	0,15
Temperature range II: 70°C / 43°C							
Displacement	δ_{N0}	[mm/(N/mm ²)]	0,06	0,09	0,12	0,16	0,18
Displacement	$\delta_{N\infty}$	[mm/(N/mm ²)]	0,17	0,23	0,19	0,19	0,18

Table C12: Displacements for HIS-N under shear load

HIS-(R)N			M8	M10	M12	M16	M20
Displacement	δ_{V0}	[mm/kN]	0,06	0,06	0,05	0,04	0,04
Displacement	$\delta_{V\infty}$	[mm/kN]	0,09	0,08	0,08	0,06	0,06

Injection system Hilti HIT-RE 500 V3

Performances
 Displacements

Annex C14

Table C13: Displacements for Hilti tension anchor HZA / HZA-R under tension load

HZA / HZA-R			M12	M16	M20	M24	M27
Non-cracked concrete							
Temperature range I: 40°C / 24°C							
Displacement	δ_{N0}	[mm/(N/mm ²)]	0,05	0,06	0,06	0,07	0,08
Displacement	$\delta_{N\infty}$	[mm/(N/mm ²)]	0,12	0,13	0,15	0,17	0,18
Temperature range II: 70°C / 43°C							
Displacement	δ_{N0}	[mm/(N/mm ²)]	0,06	0,07	0,07	0,08	0,09
Displacement	$\delta_{N\infty}$	[mm/(N/mm ²)]	0,14	0,16	0,18	0,20	0,21
Cracked concrete							
Temperature range I: 40°C / 24°C							
Displacement	δ_{N0}	[mm/(N/mm ²)]	0,05	0,08	0,10	0,13	0,15
Displacement	$\delta_{N\infty}$	[mm/(N/mm ²)]	0,14	0,19	0,16	0,16	0,15
Temperature range II: 70°C / 43°C							
Displacement	δ_{N0}	[mm/(N/mm ²)]	0,06	0,09	0,12	0,16	0,18
Displacement	$\delta_{N\infty}$	[mm/(N/mm ²)]	0,17	0,23	0,19	0,19	0,18

Table C14: Displacements for Hilti tension anchor HZA / HZA-R under shear load

HZA / HZA-R			M12	M16	M20	M24	M27
Displacement	δ_{V0}	[mm/kN]	0,05	0,04	0,04	0,03	0,03
Displacement	$\delta_{V\infty}$	[mm/kN]	0,08	0,06	0,06	0,05	0,05

Injection system Hilti HIT-RE 500 V3

Performances
 Displacements

Annex C15

Table C15: Displacements for rebar under tension load

Reinforcing bar (rebar)		φ 8	φ 10	φ 12	φ 14	φ 16	φ 20	φ 25	φ 28	φ 30	φ 32	
Non-cracked concrete												
Temperature range I: 40°C / 24°C												
Displacement	δ_{N0}	[mm/(N/mm ²)]	0,05	0,05	0,05	0,06	0,06	0,07	0,07	0,08	0,08	0,08
Displacement	$\delta_{N\infty}$	[mm/(N/mm ²)]	0,11	0,11	0,00	0,13	0,15	0,17	0,18	0,19	0,19	0,20
Temperature range II: 70°C / 43°C												
Displacement	δ_{N0}	[mm/(N/mm ²)]	0,05	0,05	0,06	0,07	0,07	0,09	0,09	0,09	0,10	0,10
Displacement	$\delta_{N\infty}$	[mm/(N/mm ²)]	0,13	0,13	0,00	0,16	0,18	0,20	0,21	0,22	0,23	0,24
Cracked concrete												
Temperature range I: 40°C / 24°C												
Displacement	δ_{N0}	[mm/(N/mm ²)]	0,03	0,03	0,06	0,08	0,10	0,14	0,15	0,16	0,18	0,19
Displacement	$\delta_{N\infty}$	[mm/(N/mm ²)]	0,19	0,19	0,06	0,19	0,16	0,16	0,15	0,16	0,18	0,19
Temperature range II: 70°C / 43°C												
Displacement	δ_{N0}	[mm/(N/mm ²)]	0,04	0,04	0,07	0,09	0,12	0,17	0,17	0,19	0,21	0,22
Displacement	$\delta_{N\infty}$	[mm/(N/mm ²)]	0,23	0,23	0,07	0,23	0,19	0,19	0,18	0,19	0,21	0,22

Table C16: Displacements for rebar under shear load

Reinforcing bar (rebar)		φ 8	φ 10	φ 12	φ 14	φ 16	φ 20	φ 25	φ 28	φ 30	φ 32	
Displacement	δ_{V0}	[mm/kN]	0,05	0,05	0,05	0,04	0,04	0,04	0,03	0,03	0,03	0,03
Displacement	$\delta_{V\infty}$	[mm/kN]	0,08	0,08	0,07	0,06	0,06	0,05	0,05	0,05	0,04	0,04

Injection system Hilti HIT-RE 500 V3

Performances
 Displacements

Annex C16

Seismic design shall be carried out according TR 045 “Design of Metal Anchors Under Seismic Action”

Table C17: Characteristic resistance for threaded rods under tension loads for seismic category C1 in concrete

Threaded rod, HIT-V-..., AM...8.8	M8	M10	M12	M16	M20	M24	M27	M30
Steel failure threaded rods								
Characteristic resistance $N_{Rk,s,seis}$ [kN]	$A_s \cdot f_{uk}$							
Combined pullout and concrete cone failure								
Characteristic bond resistance in cracked concrete C20/25 in hammer drilled holes and hammer drilled holes with Hilti hollow drill bit TE-CD or TE-YD and diamond cored holes with roughening with Hilti roughening tool TE-YRT								
Temperature range I: 40°C / 24°C $\tau_{Rk,s,seis}$ [N/mm ²]	6,0	7,0	7,9	7,9	8,0	8,2	8,3	8,1
Temperature range II: 70°C / 43°C $\tau_{Rk,s,seis}$ [N/mm ²]	4,8	5,7	6,4	6,4	6,5	6,6	6,4	6,1

Table C18: Characteristic resistance for threaded rods under shear loads for seismic category C1 in concrete

Threaded rod, HIT-V-..., AM...8.8	M8	M10	M12	M16	M20	M24	M27	M30
Steel failure without lever arm								
Characteristic resistance HIT-V, AM...8.8 $V_{Rk,s,seis}$ [kN]	$0,5 \cdot A_s \cdot f_{uk}$							
Characteristic resistance Commercial standard threaded rod $V_{Rk,s,seis}$ [kN]	$0,35 \cdot A_s \cdot f_{uk}$							

Table C19: Displacement for threaded rods under tension loads for seismic category C1 in concrete

Threaded rod, HIT-V-..., AM...8.8	M8	M10	M12	M16	M20	M24	M27	M30
Displacement ¹⁾ $\delta_{N,seis}$ [mm]	2,7	3,0	3,3	3,9	4,5	5,1	5,6	6,0

¹⁾ Maximum displacement during cycling (seismic event).

Table C20: Displacement for threaded rods under shear loads for seismic category C1 in concrete

Threaded rod, HIT-V-..., AM...8.8	M8	M10	M12	M16	M20	M24	M27	M30
Displacement ¹⁾ $\delta_{V,seis}$ [mm]	3,2	3,5	3,8	4,4	5,0	5,6	6,1	6,5

¹⁾ Maximum displacement during cycling (seismic event).

Injection system Hilti HIT-RE 500 V3

Performances

Characteristic values for seismic performance category C1 and displacements
Design according to “EOTA Technical Report TR 045, 02/2013”

Annex C17

Table C21: Characteristic resistance for internally threaded sleeve HIS-(R)N under tension load for seismic category C1 in concrete

HIS-(R)N			M8	M10	M12	M16	M20
Steel failure							
Characteristic resistance HIS-N with with screw grade 8.8	$N_{Rk,s,seis}$	[kN]	25	46	67	125	116
Characteristic resistance HIS-RN with with screw grade 70	$N_{Rk,s,seis}$	[kN]	26	41	59	110	166
Partial safety factor HIS-N with with screw grade 8.8	$\gamma_{Ms,N,seis}$	[-]	1,5				
Partial safety factor HIS-RN with with screw grade 70	$\gamma_{Ms,N,seis}$	[-]	1,87				2,4
Combined pullout and concrete cone failure							
Characteristic bond resistance in cracked concrete C20/25 in hammer drilled holes and hammer drilled holes with Hilti hollow drill bit TE-CD or TE-YD and diamond cored holes with roughening with Hilti roughening tool TE-YRT							
Temperature range I: 40°C / 24°C	$\tau_{Rk,seis}$	[N/mm ²]	8,0	8,0	8,0	8,5	8,5
Temperature range II: 70°C / 43°C	$\tau_{Rk,seis}$	[N/mm ²]	6,5	6,5	6,5	7,0	7,0

Table C22: Characteristic resistance for internally threaded sleeve HIS-(R)N under shear load for seismic category C1 in concrete

HIS-(R)N			M8	M10	M12	M16	M20
Steel failure without lever arm							
Characteristic resistance HIS-N with with screw grade 8.8	$V_{Rk,s,seis}$	[kN]	9	16	27	41	39
Characteristic resistance HIS-RN with with screw grade 70	$V_{Rk,s,seis}$	[kN]	9	14	21	39	58

Table C23: Displacement for internally threaded sleeve HIS-(R)N under tension loads for seismic category C1 in concrete

HIS-(R)N			M8	M10	M12	M16	M20
Displacement ¹⁾	$\delta_{N,seis}$	[mm]	3,4	4,0	4,6	5,3	5,6

¹⁾ Maximum displacement during cycling (seismic event).

Table C24: Displacement for internally threaded sleeve HIS-(R)N under shear loads for seismic category C1 in concrete

HIS-(R)N			M8	M10	M12	M16	M20
Displacement ¹⁾	$\delta_{V,seis}$	[mm]	3,9	4,5	5,1	5,8	6,1

¹⁾ Maximum displacement during cycling (seismic event).

Injection system Hilti HIT-RE 500 V3

Performances

Characteristic values for seismic performance category C1 and displacements
Design according to "EOTA Technical Report TR 045, 02/2013"

Annex C18

Table C25: Characteristic resistance for Hilti tension anchor HZA / HZA-R under tension load for seismic category C1 in concrete

HZA / HZA-R			M12	M16	M20	M24	M27
Steel failure							
Characteristic resistance HZA	$N_{Rk,s,seis}$	[kN]	46	86	135	194	252
Characteristic resistance HZA-R	$N_{Rk,s,seis}$	[kN]	62	111	173	249	-
Partial safety factor	$\gamma_{Ms,N,seis}$	[-]	1,4				
Combined pullout and concrete cone failure							
Characteristic bond resistance in cracked concrete C20/25 in hammer drilled holes and hammer drilled holes with Hilti hollow drill bit TE-CD or TE-YD and diamond cored holes with roughening with Hilti roughening tool TE-YRT							
Temperature range I: 40°C / 24°C	$\tau_{Rk,seis}$	[N/mm ²]	9,0	9,5	9,5	10,0	11,0
Temperature range II: 70°C / 43°C	$\tau_{Rk,seis}$	[N/mm ²]	7,5	7,5	8,0	8,0	8,0

Table C26: Characteristic resistance for Hilti tension anchor HZA / HZA-R under shear load for seismic category C1 in concrete

HZA / HZA-R			M12	M16	M20	M24	M27
Steel failure without lever arm							
Characteristic resistance HZA	$V_{Rk,s,seis}$	[kN]	23	43	67	97	126
Characteristic resistance HZA-R	$V_{Rk,s,seis}$	[kN]	31	55	86	124	-

Table C27: Displacement for Hilti tension anchor HZA / HZA-R under tension loads for seismic category C1 in concrete

HZA / HZA-R			M12	M16	M20	M24	M27
Displacement ¹⁾	$\delta_{N,seis}$	[mm]	3,3	3,9	4,5	5,3	5,7

¹⁾ Maximum displacement during cycling (seismic event).

Table C28: Displacement for Hilti tension anchor HZA / HZA-R under shear loads for seismic category C1 in concrete

HZA / HZA-R			M12	M16	M20	M24	M27
Displacement ¹⁾	$\delta_{V,seis}$	[mm]	3,8	4,4	5,0	5,8	6,2

¹⁾ Maximum displacement during cycling (seismic event).

Injection system Hilti HIT-RE 500 V3

Performances

Characteristic values for seismic performance category C1 and displacements
 Design according to "EOTA Technical Report TR 045, 02/2013"

Annex C19

Table C29: Characteristic resistance for reinforcing bars (rebars) under tension load for seismic category C1 in concrete

Reinforcing bar (rebar)	φ 8	φ 10	φ 12	φ 14	φ 16	φ 20	φ 25	φ 28	φ 30	φ 32
Steel failure rebars										
Characteristic resistance for rebar B500B acc. to DIN 488:2009-08 ¹⁾ $N_{Rk,seis}$ [kN]	-	43	62	85	111	173	270	339	388	442
Combined pullout and concrete cone failure										
Characteristic bond resistance in cracked concrete C20/25 in hammer drilled holes and hammer drilled holes with Hilti hollow drill bit TE-CD or TE-YD and diamond cored holes with roughening with Hilti roughening tool TE-YRT										
Temperature range I: 40°C / 24°C $\tau_{Rk,seis}$ [N/mm ²]	-	8,0	9,0	9,0	9,5	9,5	10,0	11,0	11,0	11,0
Temperature range II: 70°C / 43°C $\tau_{Rk,seis}$ [N/mm ²]	-	6,5	7,5	7,0	7,5	8,0	8,0	8,0	8,0	8,0

¹⁾ Values need to be calculated acc. EOTA Technical Report TR 029, Eq. 5.1, if rebars do not fulfil the requirements acc. DIN 488.

Table C30: Characteristic resistance for reinforcing bars (rebars) under shear loads for seismic category C1 in concrete

Reinforcing bar (rebar)	φ 8	φ 10	φ 12	φ 14	φ 16	φ 20	φ 25	φ 28	φ 30	φ 32
Steel failure without lever arm										
Characteristic resistance for rebar B500B acc. to DIN 488:2009-08 ¹⁾ $V_{Rk,seis}$ [kN]	-	15	22	29	39	60	95	118	135	155

¹⁾ Values need to be calculated acc. EOTA Technical Report TR 029, Eq. 5.5 with $V_{Rk,seis} = 0,7 \cdot V_{Rk,s}$, if rebars do not fulfil the requirements acc. DIN 488.

Table C31: Displacement for reinforcing bars (rebars) under tension loads for seismic category C1 in concrete

Reinforcing bar (rebar)	φ 8	φ 10	φ 12	φ 14	φ 16	φ 20	φ 25	φ 28	φ 30	φ 32
Displacement ¹⁾ $\delta_{N,seis}$ [mm]	-	3,0	3,3	3,6	3,9	4,5	5,3	5,7	6,0	6,3

¹⁾ Maximum displacement during cycling (seismic event).

Table C32: Displacement for reinforcing bars (rebars) under shear loads for seismic category C1 in concrete

Reinforcing bar (rebar)	φ 8	φ 10	φ 12	φ 14	φ 16	φ 20	φ 25	φ 28	φ 30	φ 32
Displacement ¹⁾ $\delta_{V,seis}$ [mm]	-	3,5	3,8	4,1	4,4	5,0	5,8	6,2	6,5	6,8

¹⁾ Maximum displacement during cycling (seismic event).

Injection system Hilti HIT-RE 500 V3

Performances

Characteristic values for seismic performance category C1 and displacements Design according to "EOTA Technical Report TR 045, 02/2013"

Annex C20

Table C33: Characteristic resistance for threaded rod under tension load for seismic category C2 in concrete

Threaded rod, HIT-V-..., AM...8.8	M8	M10	M12	M16	M20	M24	M27	M30
Steel failure threaded rods								
Characteristic resistance HIT-V 8.8, HIT-V-F 8.8, AM 8.8, AM-HDG 8.8, $N_{Rk,s,seis}$ [kN] Commercial standard threaded rod electroplated zinc coated	$A_s \cdot f_{uk}$							
Combined pullout and concrete cone failure								
Characteristic bond resistance in cracked concrete C20/25 in hammer drilled holes and hammer drilled holes with Hilti hollow drill bit TE-CD or TE-YD								
Temperature range I: 40°C / 24°C $\tau_{Rk,seis}$ [N/mm ²]	-	-	-	5,5	5,4	5,1	-	-
Temperature range II: 70°C / 43°C $\tau_{Rk,seis}$ [N/mm ²]	-	-	-	4,1	4,1	3,9	-	-

Table C34: Characteristic resistance for threaded rods under shear loads for seismic category C2 in concrete

Threaded rod, HIT-V-..., AM...8.8	M8	M10	M12	M16	M20	M24	M27	M30
Steel failure without lever arm, using Hilti filling set								
Characteristic resistance HIT-V 8.8 / AM 8.8 $V_{Rk,s,seis}$ [kN]	-	-	-	46	77	103	-	-
Steel failure without lever arm, without using Hilti filling set								
Characteristic resistance HIT-V 8.8 / AM 8.8 $V_{Rk,s,seis}$ [kN]	-	-	-	40	71	90	-	-
Characteristic resistance HIT-V-F 8.8 / AM-HDG 8.8 $V_{Rk,s,seis}$ [kN]	-	-	-	30	46	66	-	-
Characteristic resistance Commercial standard threaded rod electroplated zinc coated 8.8 $V_{Rk,s,seis}$ [kN]	-	-	-	28	50	63	-	-

Injection system Hilti HIT-RE 500 V3

Performances

Characteristic values for seismic performance category C2
 Design according to "EOTA Technical Report TR 045, 02/2013"

Annex C21

Table C35: Displacement for threaded rods under tension loads for seismic category C2 in concrete

Threaded rod, HIT-V-..., AM...8.8		M8	M10	M12	M16	M20	M24	M27	M30
Displacement DLS	$\delta_{N,seis(DLS)}$ [mm]	-	-	-	0,5	0,5	0,4	-	-
Displacement ULS	$\delta_{N,seis(ULS)}$ [mm]	-	-	-	1,2	0,9	0,8	-	-

Table C36: Displacement for threaded rods under shear loads for seismic category C2 in concrete

Threaded rod, HIT-V-..., AM...8.8		M8	M10	M12	M16	M20	M24	M27	M30
Installation with seismic filling set									
Displacement DLS, HIT-V 8.8 / AM 8.8	$\delta_{V,seis(DLS)}$ [mm]	-	-	-	1,2	1,4	1,1	-	-
Displacement ULS, HIT-V 8.8 / AM 8.8	$\delta_{V,seis(ULS)}$ [mm]	-	-	-	3,2	3,7	1,1	-	-
Installation without seismic filling set									
Displacement DLS, HIT-V 8.8 / AM 8.8	$\delta_{V,seis(DLS)}$ [mm]	-	-	-	3,2	2,5	2,6	-	-
Displacement DLS, HIT-V-F 8.8 / AM-HDG 8.8	$\delta_{V,seis(DLS)}$	-	-	-	2,3	3,8	3,4	-	-
Displacement ULS, HIT-V 8.8 / AM 8.8	$\delta_{V,seis(ULS)}$ [mm]	-	-	-	9,2	7,1	10,2	-	-
Displacement ULS, HIT-V-F 8.8 / AM-HDG 8.8	$\delta_{V,seis(ULS)}$ [mm]	-	-	-	4,3	9,1	8,4	-	-

Injection system Hilti HIT-RE 500 V3

Performances

Displacements for seismic performance category C2
 Design according to "EOTA Technical Report TR 045, 02/2013"

Annex C22