

www.hilti.com.hk

Company:  
Address:  
Phone | Fax: |  
Design: 123  
Fastening point:

Page: 1  
Specifier:  
E-Mail:  
Date: 29/4/2024

**Specifier's comments:**

**1 Input data**

<b>Anchor type and diameter:</b>	<b>HIT-HY 200-R + HIT-V-R M16</b>	
Return period (service life in years):	50	
Item number:	387084 HIT-V-R M16x150 (element) / 2045036 HIT-HY 200-R (adhesive)	
Effective embedment depth:	$h_{ef,opti} = 80.0 \text{ mm}$ ( $h_{ef,limit} = 114.0 \text{ mm}$ )	
Material:	A4	
Evaluation Service Report:	ETA 12/0084	
Issued   Valid:	10/12/2021   -	
Proof:	Design Method ETAG BOND (EOTA TR 029)	
Stand-off installation:		
Profile:		
Base material:	cracked concrete, C35/45, $f_{c,cube} = 45.00 \text{ N/mm}^2$ ; $h = 150.0 \text{ mm}$ , Temp. short/long: 40/24 °C	
<b>Installation:</b>	<b>hammer drilled hole, Installation condition: Dry</b>	
Reinforcement:	no reinforcement or reinforcement spacing $\geq 150 \text{ mm}$ (any $\varnothing$ ) or $\geq 100 \text{ mm}$ ( $\varnothing \leq 10 \text{ mm}$ ) no longitudinal edge reinforcement	

**Geometry [mm] & Loading [kN, kNm]**

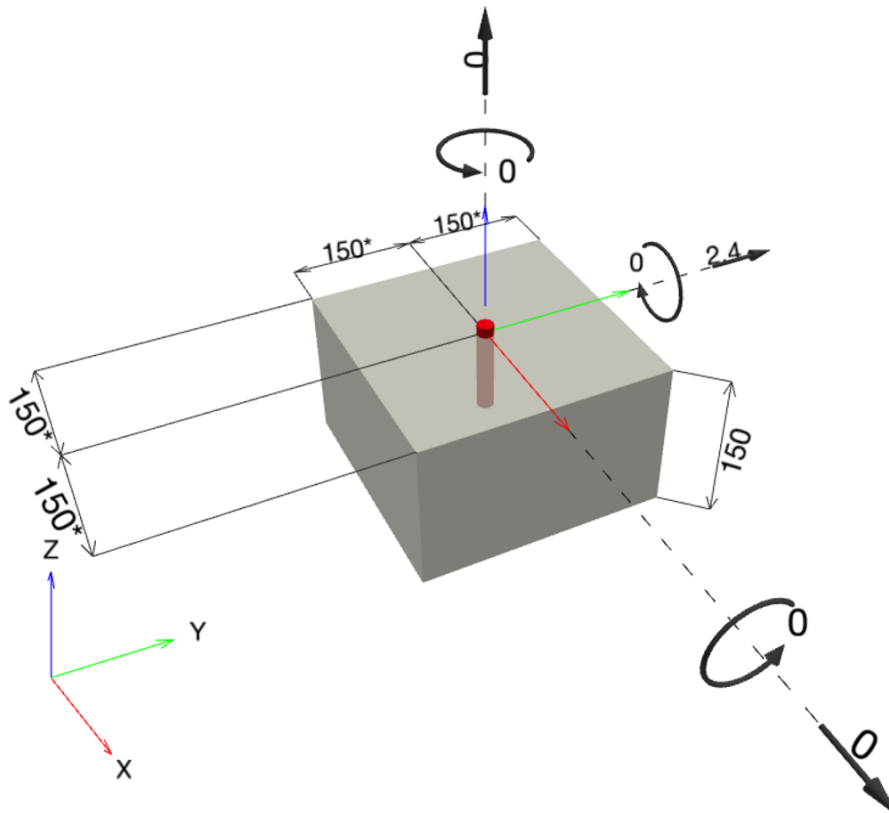

www.hilti.com.hk

Company:		Page:	2
Address:		Specifier:	
Phone   Fax:		E-Mail:	
Design:	123	Date:	29/4/2024
Fastening point:			

**1.1 Load combination**

Case	Description	Forces [kN] / Moments [kNm]	Seismic	Fire	Max. Util. Anchor [%]
1	Combination 1	N = 0.000; V <sub>x</sub> = 2.400; V <sub>y</sub> = 0.000; M <sub>x</sub> = 0.000; M <sub>y</sub> = 0.000; M <sub>z</sub> = 0.000; N <sub>sus</sub> = 0.000; M <sub>x,sus</sub> = 0.000; M <sub>y,sus</sub> = 0.000;	no	no	19
<b>2</b>	<b><u>Combination 2</u></b>	<b><u>N = 0.000; V<sub>x</sub> = 0.000; V<sub>y</sub> = 2.400;</u></b> <b><u>M<sub>x</sub> = 0.000; M<sub>y</sub> = 0.000; M<sub>z</sub> = 0.000;</u></b> <b><u>N<sub>sus</sub> = 0.000; M<sub>x,sus</sub> = 0.000; M<sub>y,sus</sub> = 0.000;</u></b>	<b><u>no</u></b>	<b><u>no</u></b>	<b><u>19</u></b>
3	Combination 3	N = 2.400; V <sub>x</sub> = 0.000; V <sub>y</sub> = 0.000; M <sub>x</sub> = 0.000; M <sub>y</sub> = 0.000; M <sub>z</sub> = 0.000; N <sub>sus</sub> = 0.000; M <sub>x,sus</sub> = 0.000; M <sub>y,sus</sub> = 0.000;	no	no	11

**2 Load case/Resulting anchor forces**

Controlling load case: 2 Combination 2

**Anchor reactions [kN]**

Tension force: (+Tension, -Compression)

Anchor	Tension force	Shear force	Shear force x	Shear force y
1	0.000	2.400	0.000	2.400



www.hilti.com.hk

---

Company:		Page:	3
Address:		Specifier:	
Phone   Fax:		E-Mail:	
Design:	123	Date:	29/4/2024
Fastening point:			

---

### 3 Tension load (EOTA TR 029, Section 5.2.2)

	Load [kN]	Capacity [kN]	Utilization $\beta_N$ [%]	Status
Steel Strength*	N/A	N/A	N/A	N/A
Concrete Breakout Failure**	N/A	N/A	N/A	N/A
Splitting failure**	N/A	N/A	N/A	N/A

\* highest loaded anchor    \*\*anchor group (anchors in tension)

www.hilti.com.hk

Company: Address: Phone   Fax:   Design: 123 Fastening point:	Page: 4 Specifier: E-Mail: Date: 29/4/2024
---	---

### 4 Shear load (EOTA TR 029, Section 5.2.3)

	Load [kN]	Capacity [kN]	Utilization $\beta_v$ [%]	Status
Steel Strength (without lever arm)*	2.400	35.224	7	OK
Steel failure (with lever arm)*	N/A	N/A	N/A	N/A
Pryout Strength**	2.400	46.080	6	OK
Concrete edge failure in direction y+**	2.400	13.200	19	OK

\* highest loaded anchor    \*\*anchor group (relevant anchors)

#### 4.1 Steel Strength (without lever arm)

$$V_{Sd} \leq V_{Rd,s} = \frac{V_{Rk,s}}{\gamma_{M,s}} \quad \text{EOTA TR 029, Table 5.2.3.1}$$

$V_{Rk,s}$ [kN]	$\gamma_{M,s}$	$V_{Rd,s}$ [kN]	$V_{Sd}$ [kN]
54.950	1.560	35.224	2.400

#### 4.2 Pryout Strength (Concrete Breakout Strength controls)

$$V_{Sd} \leq V_{Rd,cp} = \frac{V_{Rk,cp}}{\gamma_{M,c,p}} \quad \text{EOTA TR 029, Table 5.2.3.1}$$

$$V_{Rk,cp} = k \cdot \min(N_{Rk,p}; N_{Rk,c}) \quad \text{EOTA TR 029, Eq. (5.7), (5.7a)}$$

$$N_{Rk,c} = N_{Rk,c}^0 \cdot \frac{A_{c,N}}{A_0} \cdot \psi_{s,N} \cdot \psi_{re,N} \cdot \psi_{ec1,N} \cdot \psi_{ec2,N} \quad \text{EOTA TR 029, Eq. (5.3)}$$

$$N_{Rk,c}^0 = k_1 \cdot \sqrt{f_{ck,cube}} \cdot h_{ef}^{1.5} \quad \text{EOTA TR 029, Eq. (5.3a)}$$

$$A_{c,N}^0 = s_{cr,N} \cdot s_{cr,N} \quad \text{EOTA TR 029, Eq. (5.3b)}$$

$$\psi_{s,N} = 0.7 + 0.3 \cdot \frac{c}{c_{cr,N}} \leq 1.00 \quad \text{EOTA TR 029, Eq. (5.3c)}$$

$$\psi_{re,N} = 0.5 + \frac{h_{ef}}{200} \leq 1.00 \quad \text{EOTA TR 029, Eq. (5.3d)}$$

$$\psi_{ec1,N} = \frac{1}{1 + \frac{2 \cdot e_{c1,V}}{s_{cr,N}}} \leq 1.00 \quad \text{EOTA TR 029, Eq. (5.3e)}$$

$$\psi_{ec2,N} = \frac{1}{1 + \frac{2 \cdot e_{c2,V}}{s_{cr,N}}} \leq 1.00 \quad \text{EOTA TR 029, Eq. (5.3e)}$$

$A_{c,N}$ [mm <sup>2</sup> ]	$A_{c,N}^0$ [mm <sup>2</sup> ]	$c_{cr,N}$ [mm]	$s_{cr,N}$ [mm]	k-factor	$k_1$
57,600	57,600	120.0	240.0	2.000	7.200
$e_{c1,V}$ [mm]	$\psi_{ec1,N}$	$e_{c2,V}$ [mm]	$\psi_{ec2,N}$	$\psi_{s,N}$	$\psi_{re,N}$
0.0	1.000	0.0	1.000	1.000	1.000
$N_{Rk,c}^0$ [kN]	$\gamma_{M,c,p}$	$V_{Rd,cp}$ [kN]	$V_{Sd}$ [kN]		
34.560	1.500	46.080	2.400		

Group anchor ID

1

[www.hilti.com.hk](http://www.hilti.com.hk)

Company:

Address:

Phone | Fax:

Design:

Fastening point:

 |  
123

Page:

Specifier:

E-Mail:

Date:

5

29/4/2024

**4.3 Concrete edge failure in direction y+**

$$V_{Sd} \leq V_{Rd,c} = \frac{V_{Rk,c}}{\gamma_{M,c}} \quad \text{EOTA TR 029, Table 5.2.3.1}$$

$$V_{Rk,c} = V_{Rk,c}^0 \cdot \frac{A_{c,V}}{A_{c,V}^0} \cdot \psi_{s,V} \cdot \psi_{h,V} \cdot \psi_{\alpha,V} \cdot \psi_{ec,V} \cdot \psi_{re,V} \quad \text{EOTA TR 029, Eq. (5.8)}$$

$$V_{Rk,c}^0 = k_1 \cdot d_{nom}^\alpha \cdot h_{ef}^\beta \cdot \sqrt{f_{ck,cube}} \cdot c_1^{1.5} \quad \text{EOTA TR 029, Eq. (5.8a)}$$

$$\alpha = 0.1 \cdot \left( \frac{h_{ef}}{c_1} \right)^{0.5} \quad \text{EOTA TR 029, Eq. (5.8b)}$$

$$\beta = 0.1 \cdot \left( \frac{d_{nom}}{c_1} \right)^{0.2} \quad \text{EOTA TR 029, Eq. (5.8c)}$$

$$A_{c,V}^0 = 4.5 \cdot c_1^2 \quad \text{EOTA TR 029, Eq. (5.8d)}$$

$$\psi_{s,V} = 0.7 + 0.3 \cdot \frac{c_2}{1.5 \cdot c_1} \leq 1.00 \quad \text{EOTA TR 029, Eq. (5.8e)}$$

$$\psi_{h,V} = \left( \frac{1.5 \cdot c_1}{h} \right)^{0.5} \geq 1.00 \quad \text{EOTA TR 029, Eq. (5.8f)}$$

$$\psi_{\alpha,V} = \sqrt{\frac{1}{(\cos \alpha_V)^2 + \left( \frac{\sin \alpha_V}{2.5} \right)^2}} \geq 1.00 \quad \text{EOTA TR 029, Eq. (5.8g)}$$

$$\psi_{ec,V} = \frac{1}{1 + \frac{2 \cdot e_{c,V}}{3 \cdot c_1}} \leq 1.00 \quad \text{EOTA TR 029, Eq. (5.8h)}$$

$$c_1 = \max \left( \frac{c_{2,max}}{1.5}, \frac{h}{1.5}, \frac{s_{2,max}}{3} \right)$$

$h_{ef}$ [mm]	$d_{nom}$ [mm]	$k_1$	$\alpha$	$\beta$		
80.0	16.00	1.700	0.089	0.069		
$c_1$ [mm]	$c_1'$ [mm]	$A_{c,V}$ [mm <sup>2</sup> ]	$A_{c,V}^0$ [mm <sup>2</sup> ]			
150.0	100.0	45,000	45,000			
$\psi_{s,V}$	$\psi_{h,V}$	$\alpha_V$ [°]	$\psi_{\alpha,V}$	$e_{c,V}$ [mm]	$\psi_{ec,V}$	$\psi_{re,V}$
1.000	1.000	0.00	1.000	0.0	1.000	1.000
$V_{Rk,c}^0$ [kN]	$\gamma_{M,c}$	$V_{Rd,c}$ [kN]	$V_{Sd}$ [kN]			
19.800	1.500	13.200	2.400			

**www.hilti.com.hk**

Company:

Address:

Phone | Fax:

Design: | 123

Fastening point:

Page:

6

Specifier:

E-Mail:

Date:

29/4/2024

## 5 Displacements (highest loaded anchor)

Short term loading:

$$N_{Sk} = 0.000 \text{ [kN]} \quad \delta_N = 0.0000 \text{ [mm]}$$

$$V_{Sk} = 1.778 \text{ [kN]} \quad \delta_V = 0.0711 \text{ [mm]}$$

$$\delta_{NV} = 0.0711 \text{ [mm]}$$

Long term loading:

$$N_{Sk} = 0.000 \text{ [kN]} \quad \delta_N = 0.0000 \text{ [mm]}$$

$$V_{Sk} = 1.778 \text{ [kN]} \quad \delta_V = 0.1067 \text{ [mm]}$$

$$\delta_{NV} = 0.1067 \text{ [mm]}$$

Comments: Tension displacements are valid with half of the required installation torque moment for uncracked concrete! Shear displacements are valid without friction between the concrete and the anchor plate! The gap due to the drilled hole and clearance hole tolerances are not included in this calculation!

The acceptable anchor displacements depend on the fastened construction and must be defined by the designer!

## 6 Warnings

- The anchor design methods in PROFIS Engineering require rigid anchor plates per current regulations (AS 5216:2021, ETAG 001/Annex C, EOTA TR029 etc.). This means load re-distribution on the anchors due to elastic deformations of the anchor plate are not considered - the anchor plate is assumed to be sufficiently stiff, in order not to be deformed when subjected to the design loading. PROFIS Engineering calculates the minimum required anchor plate thickness with CBFEM to limit the stress of the anchor plate based on the assumptions explained above. The proof if the rigid anchor plate assumption is valid is not carried out by PROFIS Engineering. Input data and results must be checked for agreement with the existing conditions and for plausibility!
- Checking the transfer of loads into the base material is required in accordance with EOTA TR 029, Section 7!
- The design is only valid if the clearance hole in the fixture is not larger than the value given in Table 4.1 of EOTA TR029! For larger diameters of the clearance hole see Chapter 1.1. of EOTA TR029!
- The accessory list in this report is for the information of the user only. In any case, the instructions for use provided with the product have to be followed to ensure a proper installation.
- Bore hole cleaning must be performed according to instructions for use (blow twice with oil-free compressed air (min. 6 bar), brush twice, blow twice with oil-free compressed air (min. 6 bar)).
- Characteristic bond resistances depend on short- and long-term temperatures.
- Please contact Hilti to check feasibility of HIT-V rod supply.
- Edge reinforcement is not required to avoid splitting failure
- The characteristic bond resistances depend on the return period (service life in years): 50

**Fastening meets the design criteria!**

www.hilti.com.hk

Company:		Page:	7
Address:		Specifier:	
Phone   Fax:		E-Mail:	
Design:	123	Date:	29/4/2024
Fastening point:			

## 7 Installation data

Anchor plate, steel: -	Anchor type and diameter: HIT-HY 200-R + HIT-V-R M16
Profile: -	Item number: 387084 HIT-V-R M16x150 (element) / 2045036 HIT-HY 200-R (adhesive)
Hole diameter in the fixture: -	Maximum installation torque: 80 Nm
Plate thickness (input): -	Hole diameter in the base material: 18.0 mm
	Hole depth in the base material: 80.0 mm
Drilling method: Hammer drilled	Minimum thickness of the base material: 116.0 mm
Cleaning: Compressed air cleaning of the drilled hole according to instructions for use is required	

Hilti HAS-U threaded rod with HIT-HY 200 injection mortar with 80 mm embedment  $h_{ef}$ , M16, Stainless steel, Hammer drilled installation per ETA 12/0084

### 7.1 Recommended accessories

Drilling	Cleaning	Setting
<ul style="list-style-type: none"><li>• Suitable Rotary Hammer</li><li>• Properly sized drill bit</li></ul>	<ul style="list-style-type: none"><li>• Compressed air with required accessories to blow from the bottom of the hole</li><li>• Proper diameter wire brush</li></ul>	<ul style="list-style-type: none"><li>• Dispenser including cassette and mixer</li><li>• Torque wrench</li></ul>

### Coordinates Anchor [mm]

Anchor	x	y	C <sub>-x</sub>	C <sub>+x</sub>	C <sub>-y</sub>	C <sub>+y</sub>
1	0.0	0.0	150.0	150.0	150.0	150.0



www.hilti.com.hk

---

Company:		Page:	8
Address:		Specifier:	
Phone   Fax:		E-Mail:	
Design:	123	Date:	29/4/2024
Fastening point:			

---

## 8 Remarks; Your Cooperation Duties

- Any and all information and data contained in the Software concern solely the use of Hilti products and are based on the principles, formulas and security regulations in accordance with Hilti's technical directions and operating, mounting and assembly instructions, etc., that must be strictly complied with by the user. All figures contained therein are average figures, and therefore use-specific tests are to be conducted prior to using the relevant Hilti product. The results of the calculations carried out by means of the Software are based essentially on the data you put in. Therefore, you bear the sole responsibility for the absence of errors, the completeness and the relevance of the data to be put in by you. Moreover, you bear sole responsibility for having the results of the calculation checked and cleared by an expert, particularly with regard to compliance with applicable norms and permits, prior to using them for your specific facility. The Software serves only as an aid to interpret norms and permits without any guarantee as to the absence of errors, the correctness and the relevance of the results or suitability for a specific application.
- You must take all necessary and reasonable steps to prevent or limit damage caused by the Software. In particular, you must arrange for the regular backup of programs and data and, if applicable, carry out the updates of the Software offered by Hilti on a regular basis. If you do not use the AutoUpdate function of the Software, you must ensure that you are using the current and thus up-to-date version of the Software in each case by carrying out manual updates via the Hilti Website. Hilti will not be liable for consequences, such as the recovery of lost or damaged data or programs, arising from a culpable breach of duty by you.