

Design/System/Construction/Assembly Usage Disclaimer

- Authorities Having Jurisdiction should be consulted in all cases as to the particular requirements covering the installation and use of UL Certified products, equipment, system, devices, and materials.
- Authorities Having Jurisdiction should be consulted before construction.
- Fire resistance assemblies and products are developed by the design submitter and have been investigated by UL for compliance with applicable requirements. The published information cannot always address every construction nuance encountered in the field.
- When field issues arise, it is recommended the first contact for assistance be the technical service staff provided by the product manufacturer noted for the design. Users of fire resistance assemblies are advised to consult the general Guide Information for each product category and each group of assemblies. The Guide Information includes specifics concerning alternate materials and alternate methods of construction.
- Only products which bear UL's Mark are considered Certified.

XHBN - Joint Systems

[See General Information for Joint Systems](#)

System No. HW-D-0440

December 03, 2020

Assembly Rating — 2 Hr

Nominal Joint Width — 2 In.

L Rating At Ambient — Less Than 1 CFM/Lin Ft

L Rating At 400°F — Less Than 1 CFM/Lin Ft

Class II Movement Capabilities — 12.5% Compression or Extension

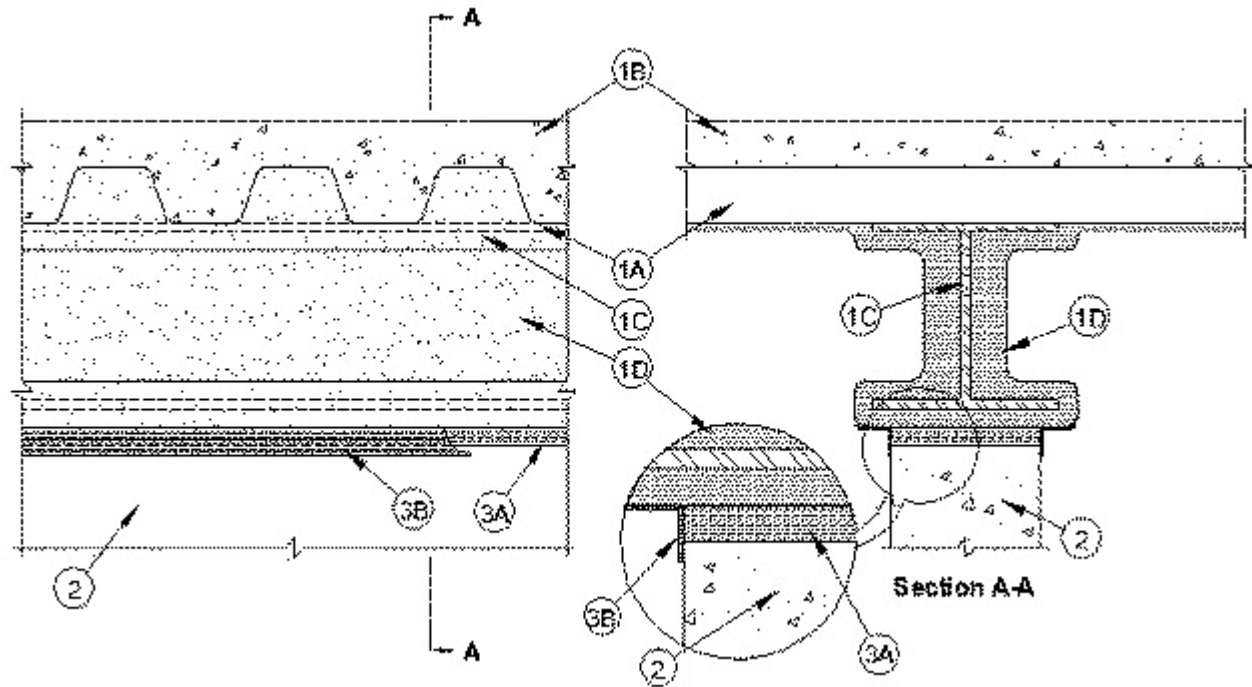

1. **Floor Assembly** — The fire-rated fluted steel deck/concrete floor assembly shall be constructed of the materials and in the manner described in the individual D700 Series Floor-Ceiling Design in the UL Fire Resistance Directory and shall include the following construction features:

A. **Steel Floor And Floor Units*** — Max 3 in. (76 mm) deep galv steel fluted floor units.

B. **Concrete** — Min 2-1/2 in. (64 mm) thick reinforced concrete, as measured from the top plane of the floor units.

C. **Structural Steel Support** — Steel beam, as specified in the individual D700 Series Floor-Ceiling Design, used to support steel floor units. Steel beam centered over and parallel with wall assembly. Structural steel support may be parallel or perpendicular to steel floor units.

D. **Spray-Applied Fire Resistive Material*** — Steel floor units and structural steel support to be sprayed with the thickness of material specified in the individual D700 Series Design. The flutes of the steel floor units are to be filled with material across the entire top flange of the steel beam when beam runs perpendicular to steel floor units. Additional material shall be applied to the web of the steel beam on each side of the wall. The thickness of material applied to each side of the steel beam web shall be 1-3/8 in. (35 mm).

GCP APPLIED TECHNOLOGIES INC — Type MK-6/HY, MK-10HB

D1. **Spray-Applied Fire Resistive Material*** — Steel floor units and structural steel support to be sprayed with the min thickness of material specified in the individual D700 Series Design. The flutes of the steel floor units are to be filled with material across the entire top flange of the steel beam when beam runs perpendicular to steel floor units.

Additional material shall be applied to the web of the steel beam on each side of the wall. The thickness of material applied to each side of the steel beam web shall be 1-1/2 in. (38 mm).

ISOLATEK INTERNATIONAL — Type 300, Type 400

2. **Wall Assembly** — Min 8 in. (203 mm) thick reinforced lightweight or normal weight (100-150 pcf or 1600-2400 kg/m³) concrete. Wall may also be constructed of any UL Classified **Concrete Block***. Concrete wall to be centered beneath and parallel with bottom flange of steel beam.

See **Concrete Block** (CAZT) category in Fire Resistance Directory for names of manufacturers

3. **Joint System** — Max separation between spray applied fire resistive material on bottom of structural support member and top of concrete wall (at time of installation of joint system) is 2 in. (51 mm). The joint system is designed

to accommodate a max 12.5 percent compression or extension from it's installed width as measured between bottom plane of protected steel beam and top of concrete wall. The joint system shall consist of forming and fill materials as follows:

A. **Forming Material*** — Min 8 in. (203 mm) wide section of nom 4 pcf (64 kg/m³) mineral wool batt insulation compressed 50 percent in thickness and installed cut edge first to completely fill the gap above the top of the concrete wall. The forming material shall be installed flush with both surfaces of wall.

THERMAFIBER INC — Type SAF

B. **Fill, Void or Cavity Material*— Sealant** — Min 1/8 in. (3.2 mm) wet thickness (min 1/16 in. or 1.6 mm dry thickness) of fill material sprayed or troweled on each side of wall to completely cover mineral wool forming material and to overlap min 1/2 in. (13 mm) onto concrete wall and min 2 in. (51 mm) onto spray-applied fire resistive material.

HILTI CONSTRUCTION CHEMICALS, DIV OF HILTI INC — CP672 Firestop Spray or CFS-SP WB Firestop Joint Spray

*** Indicates such products shall bear the UL or cUL Certification Mark for jurisdictions employing the UL or cUL Certification (such as Canada), respectively.**

Last Updated on 2020-12-03

The appearance of a company's name or product in this database does not in itself assure that products so identified have been manufactured under UL Solutions' Follow - Up Service. Only those products bearing the UL Mark should be considered to be Certified and covered under UL Solutions' Follow - Up Service. Always look for the Mark on the product.

UL Solutions permits the reproduction of the material contained in Product iQ subject to the following conditions: 1. The Guide Information, Assemblies, Constructions, Designs, Systems, and/or Certifications (files) must be presented in their entirety and in a non-misleading manner, without any manipulation of the data (or drawings). 2. The statement "Reprinted from Product iQ with permission from UL Solutions" must appear adjacent to the extracted material. In addition, the reprinted material must include a copyright notice in the following format: "©2024 UL LLC."