

351F-2000-12-9s

**CRANE SPECIFICATIONS:**  
 CAPACITY: 2000 lbs.  
 SPAN: 12'-0"  
 HEIGHT UNDER BOOM: 9'-2"  
 ANCHOR PULL FORCE: 1575 lbs./bolt  
 OVERTURNING MOMENT: 33073 ft.-lbs.  
 APPROX. WEIGHT: 1310 lbs.

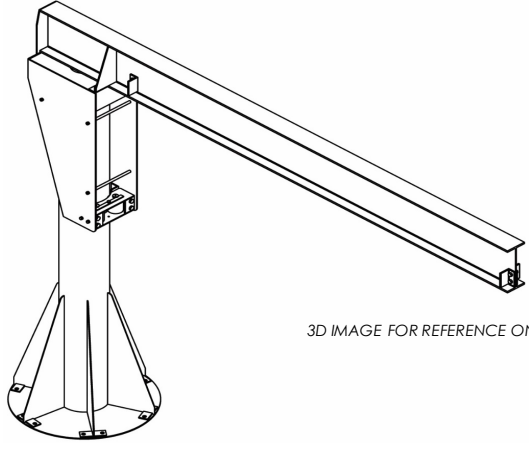

3D IMAGE FOR REFERENCE ONLY

IT IS RECOMMENDED THAT FOUNDATIONLESS JIB CRANES BE MOUNTED ON REINFORCED CONCRETE WITH A MINIMUM DEPTH OF 6" AVOIDING ANY GAPS, CRACKS, OR EXPANSION JOINTS (WITHIN A GIVEN AREA, SIZE OF AREA TO BE DETERMINED BY QUALIFIED ENGINEER) ANCHOR BOLTS MUST HAVE A 4 3/4" MINIMUM EMBEDMENT.

IT IS NOT HANDLING SYSTEMS INTERNATIONAL INC.'S RESPONSIBILITY TO VERIFY THE SUITABILITY OF A FLOOR OR STRUCTURE TO WHICH OUR PRODUCT IS MOUNTED. PRIOR TO MOUNTING, IT IS REQUIRED THAT THE CUSTOMER/END USER SEEK ADVICE FROM A QUALIFIED ENGINEER.

PRELIMINARY QUOTE DRAWING

<small>PROPRIETARY &amp; CONFIDENTIAL</small> THE INFORMATION CONTAINED IN THIS DRAWING IS THE SOLE PROPERTY OF HANDLING SYSTEMS INTERNATIONAL, INC. ANY REPRODUCTION IN PART OR AS A WHOLE WITHOUT THE WRITTEN PERMISSION OF HANDLING SYSTEMS INTERNATIONAL, INC. IS PROHIBITED.		
	<b>HEAVY DUTY FREESTANDING JIB CRANE</b>	
MODEL: 351F-2000-12-9s	DO NOT SCALE FROM DRAWING	
<b>TOLERANCES:</b>		
<small>DECIMALS (UNLESS OTHERWISE SPECIFIED) - TWO PLACE (.00) +/- .015 - THREE (.000) +/- .005          ANGLES +/- 30 MINUTES - ALL DIMENSIONS ARE IN INCHES UNLESS OTHERWISE SPECIFIED.</small>		