

**INSULATED METAL PIPE THROUGH GYPSUM SHAFT WALL ASSEMBLY**

F-RATING = 1-HR.  
T-RATING = 1-HR.

WL5144d.011415

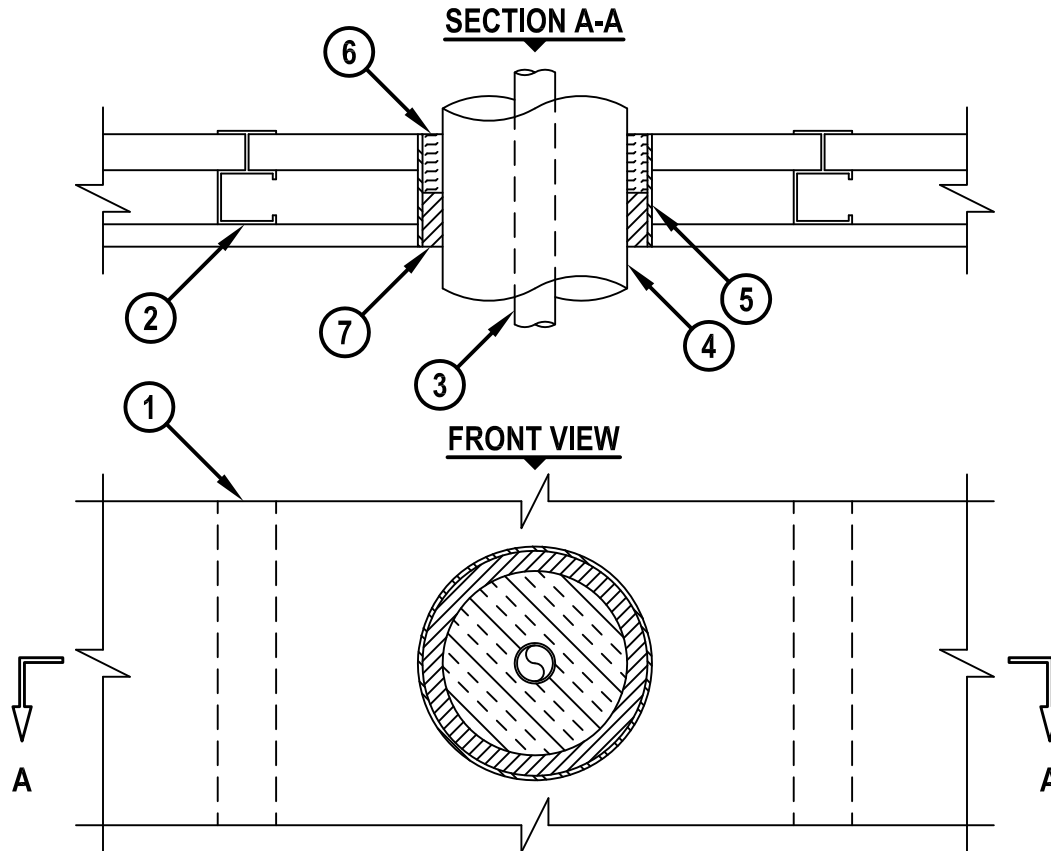

1. GYPSUM SHAFT WALL ASSEMBLY (UL/cUL CLASSIFIED U400 SERIES) (1-HR. FIRE-RATING).
2. "C-T" SHAPED STEEL STUDS (1-5/8" WIDE x 2-1/2" DEEP, MIN. 25 GA.) SPACED MAXIMUM 24" C/C.
3. MAXIMUM 1" NOMINAL DIAMETER COPPER TUBE.
4. NOMINAL 2" THICK GLASS-FIBER PIPE INSULATION.
5. MAXIMUM 6-1/2" DIAMETER SHEET METAL SLEEVE (MIN. 28 GA.) OR NO. 8 STEEL WIRE MESH HAVING MINIMUM 1" OVERLAP ALONG LONGITUDINAL SEAM.
6. MINIMUM 1-5/8" THICKNESS MINERAL WOOL (MIN. 4 PCF DENSITY) TIGHTLY PACKED AND RECESSED ON ONE SIDE OF WALL FOR FIRESTOP SEALANT.
7. MINIMUM 1-1/2" DEPTH HILTI FS-ONE MAX OR FS-ONE INTUMESCENT FIRESTOP SEALANT.

**NOTES :**

1. MAXIMUM DIAMETER OF OPENING = 6-1/2".
2. ANNULAR SPACE = MINIMUM 1/4", MAXIMUM 1-1/8".
3. AS AN ALTERNATE TO THE ABOVE SHAFT WALL ASSEMBLY, A 1 OR 2-HR. GYPSUM WALL ASSEMBLY MAY BE USED (U300, U400 OR V400 SERIES). STEEL STUDS TO BE MINIMUM 2-1/2" WIDE. WOOD STUDS TO CONSIST OF NOMINAL 2 x 4 LUMBER.
4. WHEN SYSTEM IS INSTALLED IN A STANDARD WALL ASSEMBLY, MINERAL WOOL SHOULD BE INSTALLED FLUSH WITH EITHER SIDE OF WALL AND RECESSED FROM OTHER SIDE TO ACCOMMODATE SEALANT.



HILTI, Inc.  
Tulsa, Oklahoma USA (800) 879-8000

Sheet	1 of 1
Scale	3/16" = 1"
Date	Jan. 14, 2015

Drawing No.  
**WL  
5144d**